

Mini Auger

Operation and Maintenance Manual

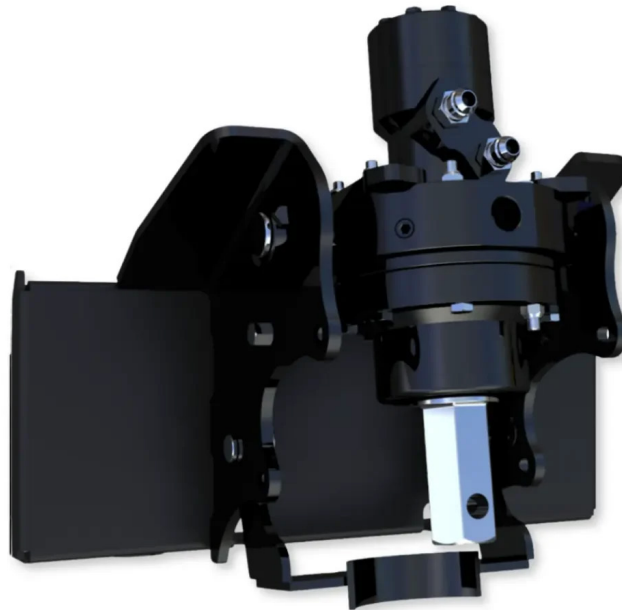

Register your
WARRANTY
within 30 days
of purchase



888-376-7027 | BlueDiamondAttachments.com



BD-092

Introduction: Owner Information

Thank you for your decision to purchase a Blue Diamond® Mini Auger. To ensure maximum performance of your equipment, it is mandatory that you thoroughly study the Operator's Manual and follow the recommendations. Proper operation and maintenance are essential to maximize equipment life and prevent personal injury.

Operate and maintain this equipment in a safe manner and in accordance with all applicable local, state, and federal codes, regulations and/or laws. Follow all on-product labeling and instructions.

Make sure that all personnel have read this Operator's Manual and thoroughly understand safe and correct operating, installation, and maintenance procedures.

Blue Diamond® is continually working to improve its products. Blue Diamond® reserves the right to make any improvements or changes as deemed practical and possible without incurring any responsibility or obligation to make any changes or additions to equipment sold previously.

Although great care has been taken to ensure the accuracy of this publication, Blue Diamond® makes no warranty or guarantee of any kind, written or expressed, implied or otherwise with regard to the information contained within this manual. Blue Diamond® assumes no responsibility for any errors that may appear in this manual and shall not be liable under any circumstances for incidental, consequential, or punitive damages in connection with or arising from the use of this manual.

Keep this manual available for frequent reference. All new operators or owners must review the manual before using the equipment and annually thereafter. Contact your Blue Diamond® Attachments Dealer for assistance, information, or additional copies of the manual. Contact www.bluediamondattachments.com or call 888-376-7027 for a complete list of dealers in your area.

Serial Number Location:

Please record attachment information in the space provided for future reference.

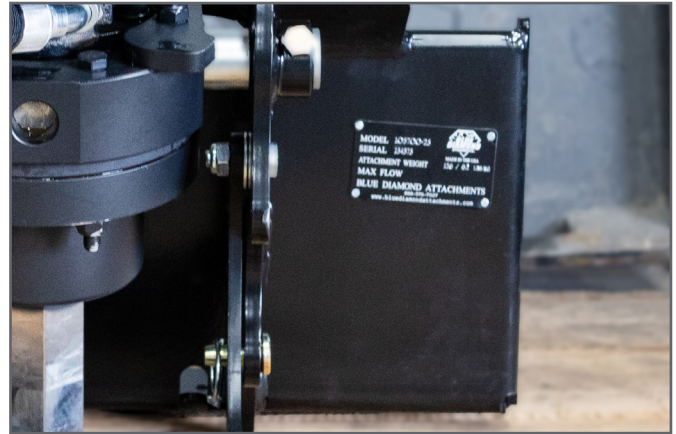

Model Number: _____

Serial Number: _____

Dealer Name: _____

Dealer Number: _____

Date of Purchase: _____

The serial number plate is located on the left side on the front of the mount as shown above.

Always use your serial number when requesting information or when ordering parts.

NOTE: The directions left, right, front, and rear, as mentioned throughout this manual, are as viewed from the operator's position.

Table of Contents

Introduction: Owner Information	2	7.3 Heavy Duty Bits – 4’ Length	40
1. Pre-Delivery Inspection Instructions	4	7.4 Heavy Duty with Cast Head Bits – 4’ Length	42
1.1 Safety & Documentation	4	7.5 Tree Bits – 4’ Length	44
1.2 Visual Inspection	4	7.6 Rock Bits – 4’ Length	45
1.3 Hydraulic System & Operational Test	4	8. Specifications	46
1.4 Final Delivery	4	8.1 Attachment Specifications	46
2. Introduction.....	5	8.2 Torque Specifications – Metric	47
2.1 Attachment Identification	5	Warranty	49
2.2 About this Attachment	6		
2.3 Attachment Model Numbers	6		
3. Safety	7		
3.1 General Safety Information	7		
3.2 Operators	8		
3.3 Safety Guidelines	9		
3.3 Safety Guidelines Cont’d	10		
4. Operation	12		
4.1 Pre-Operation Inspection	12		
4.2 Setup Procedure	13		
4.3 Entering & Exiting the Prime Mover	13		
4.4 Attachment Installation	14		
4.5 Installing Bits & Extensions to the Auger Drive	15		
4.6 Cold Weather Startup Information	16		
4.7 Operating the Attachment	16		
4.8 Operating Positions	17		
5. Maintenance.....	19		
5.1 Service Schedule	19		
5.2 Gear Oil Change Schedule	20		
5.3 How to Check the Gearbox Oil Level	21		
5.4 How to Drain Gearbox Oil	21		
5.5 How to Change or Refill the Gearbox Oil	22		
5.6 Output Shaft Seal Replacement	23		
5.7 How to Replace Teeth on Auger Bits	24		
5.8 Maintaining Auger Bits	26		
5.9 Spare Parts & Accessories	26		
5.10 Storage	27		
5.11 Troubleshooting	28		
6. Parts.....	30		
6.1 2-Way Swing Main Components	30		
6.2 4-Way Swing Main Components	32		
6.3 Gearbox Components – Both Models	34		
6.4 Safety Decals	36		
7. Auger Bits	38		
7.1 Teeth	38		
7.2 Pilot/Fishtail	39		

1. Pre-Delivery Inspection Instructions

Use this checklist to verify safety, function, and readiness prior to delivery.

END USER'S NAME: _____

DATE: _____

ITEM NUMBER & DESCRIPTION: _____

SERIAL NO.: _____

HOST MACHINE MAKE/MODEL: _____

1.1 Safety & Documentation

- Operation and Maintenance Manual is included.
- Safety decals are present and legible.
- Model and serial number plate is present and intact.
- Verify required hydraulic flow range for customer's host machine.

1.2 Visual Inspection

- Unit is free of shipping damage, dents, cracked welds, etc.
- Verify motor and safety covers are in place and secure.
- Ensure drive system is correctly lubricated.
- Fasteners are properly torqued.

1.3 Hydraulic System & Operational Test

- Hydraulic hose routing is appropriate for application.

- Fittings are properly tightened; verify no leakage.
- Quick couplers are correct and clean.
- Case drain line is installed.
- Smooth operation; no hydraulic leaks or excessive vibration of attachment.
- Verify attachment has been connected to the host machine that will be used for operation and tested.
- Verify the host machine's hydraulic flow with a flow meter.

1.4 Final Delivery

- Maintenance schedule located in Operation and Maintenance Manual has been reviewed.
- Grease type and intervals were provided.
- Teeth change procedure and maintenance safety have been explained.
- Register the attachment for warranty by following the instructions below:
 - Fill out this form and email it to warranty@battachments.com

TECHNICIAN: _____

CUSTOMER: _____

DATE: _____

2. Introduction

2.1 Attachment Identification

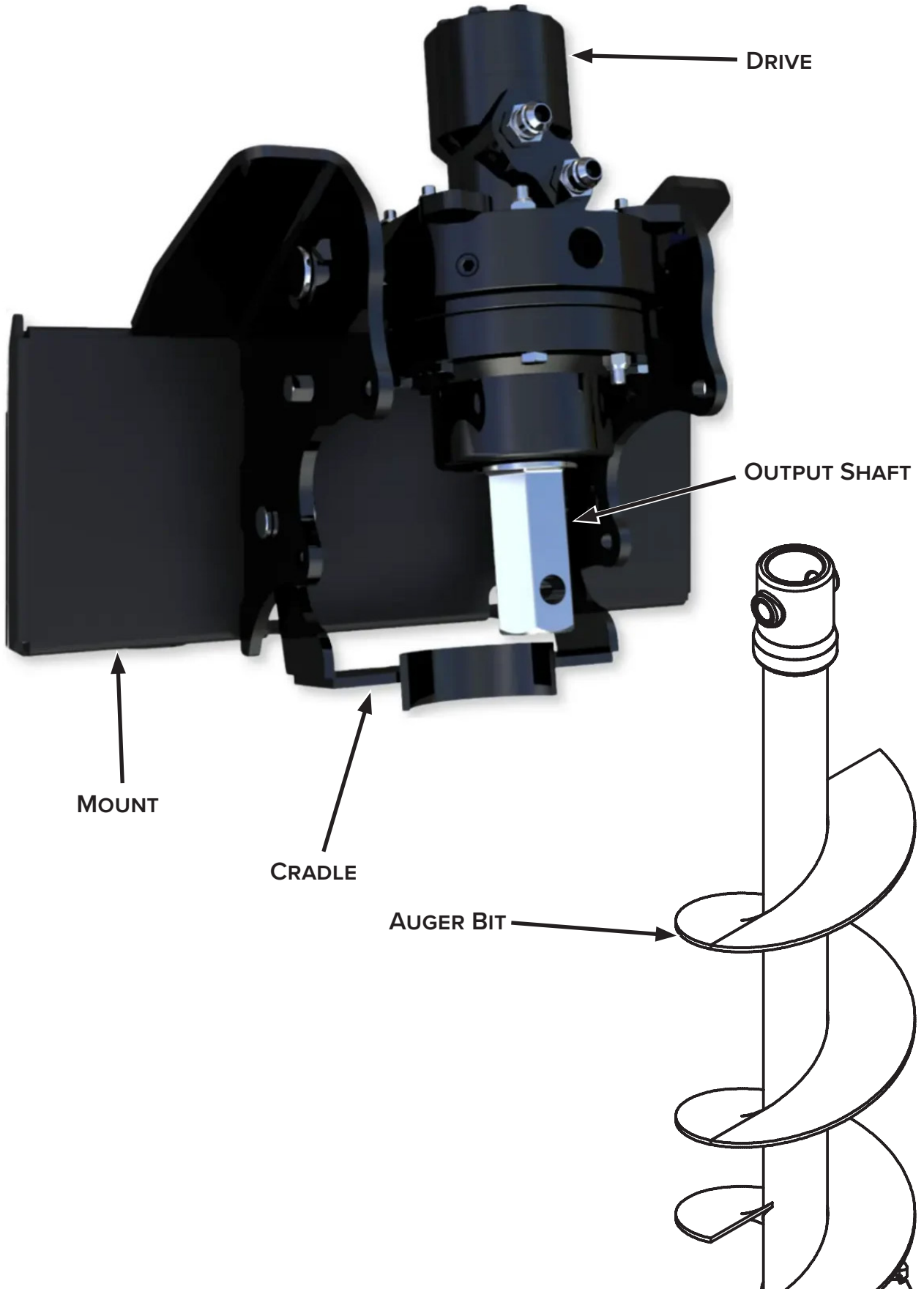

2. Introduction

2.2 About this Attachment

The Blue Diamond® Mini Auger drives are designed for most mini skid steer and small compact track loaders under 20 HP. Choose the 2-way (fore/aft) swing auger drive for standard applications, such as post hole drilling, piers, fencing, and general purpose use. For sloped terrain, especially where side-to-side leveling is needed, opt for the 4-way (fore/aft and left/right) model. It is designed to drill precise perpendicular holes on uneven ground.

2.3 Attachment Model Numbers

MODEL NUMBER	DESCRIPTION	RECOMMENDED FLOW
105700	2-Way Swing	6 – 16 GPM
105702	4-Way Swing	6 – 16 GPM

3. Safety

3.1 General Safety Information



This **SAFETY ALERT SYMBOL** identifies important safety messages on the equipment and in the owner's manual. When you see this symbol, be alert to the possibility of personal injury and carefully read the message that follows.



The signal word **IMPORTANT** identifies procedures which must be followed to avoid damage to the machine.



The signal word **DANGER** on the machine and in the manuals indicates a hazardous situation which, if not avoided, will result in death or serious injury.



The signal word **WARNING** on the machine and in the manuals indicates a potentially hazardous situation which, if not avoided, could result in death or serious injury.



The signal word **CAUTION** on the machine and in the manuals indicates a potentially hazardous situation which, if not avoided, may result in minor or moderate injury. It may also be used to alert against unsafe practices.

NOTE: Notes are used to indicate important information. This information may be repeated in other areas of the manual.

Terminology

Host Machine, Machine, Prime Mover:

- The Mini Auger can be attached to many different pieces of equipment; therefore, the terms “host machine”, “machine”, and “prime mover” will be used. Host machine, machine, and prime mover mean any vehicle, tractor, or skid steer providing power to the attachment.

Attachment, Implement, Equipment:

- The Mini Auger is the tool that is being attached to the host machine; therefore, the terms “attachment”, “implement”, and “equipment” will be used. The attachment, implement, and equipment mean any tool that is being used on any vehicle, tractor, or skid steer being used for different applications.

Operating Safety

- Read and follow instructions in this manual and the machine's Operator's Manual before operating.
- The manual must always remain with the machine. In case of loss or damage, request a new copy from your dealer or from Blue Diamond®.
- Strictly follow all rules prescribed by the safety pictograms/decals applied to the machine. Ensure that all safety pictograms/decals are legible. If pictograms/decals are worn, they must be replaced with new ones obtained from Blue Diamond® and placed in the position indicated by this manual.
- Before using the machine, make sure that all safety devices are installed and in good working condition. In case of damaged or missing shields, replace them immediately.
- It is absolutely forbidden to remove or alter safety devices and/or safety precautions
- Pay maximum attention to avoid any accidental contact with rotating parts of the machine.
- If the use of the machine is required at night or in conditions of reduced visibility, use the lighting system of the prime mover and an auxiliary lighting system if required.

3. Safety

3.1 General Safety Information Cont'd

Operating Safety Cont'd

- Exposure to respirable crystalline silica dust along with other hazardous dusts may cause serious or fatal respiratory disease. It is recommended to use dust suppression, dust collection, and if necessary, personal protective equipment (PPE) during the operation of any attachment that may cause high levels of dust.
- Remove paint before welding or heating. Hazardous fumes/dust can be generated when paint is heated by welding, soldering, or using a torch. Do all work outside or in a well ventilated area and dispose of paint and solvent properly. When sanding or grinding paint, wear an approved respirator. If you use a solvent or paint stripper, remove the stripper with soap and water before welding. Remove solvent or paint stripper containers and other flammable material from the area.

3.2 Operators

Qualified Operators

The operator is a person suited to the work and who is physically and psychologically able to withstand the demands connected with operating the equipment for its intended use. The operator must not allow anyone to approach the machine while it is working and must not allow external personnel to operate the machine or attachment.

The operator is to follow the given instructions in this manual and the machine operator's manual in order to obtain maximum performance, minimal fuel consumption, and maximum safety for himself and for others.

The operator is responsible for scrupulously observing all the instructions given in this manual.



DANGER



AVOID SERIOUS INJURY OR DEATH

Operators must receive instructions before operating the machine. Untrained operators can cause serious injury or death.

For an operator to be qualified, he or she must not use drugs or alcoholic drinks which impair alertness or coordination while working. An operator who is taking prescription drugs must get medical advice to determine if he or she can safely operate a machine and the equipment. For an operator to be qualified, he or she must have read and understood the instructions of this manual, he or she must make adequate preparation for the proper use of the machine, and he or she must hold a driving license.

In case of doubt regarding the use of the machine and/or the interpretation of this manual, the operator must contact either their dealer or Blue Diamond®.

Operator Training

- Check the rules and regulations at your location. The rules may include an employer's work safety requirements. Regulations may apply to local driving requirements or use of a Slow Moving Vehicle (SMV) emblem. Regulations may identify a hazard such as a utility line.
- It is the skill, care, common sense, and good judgment of the operator that will determine how efficiently and safely the job is performed.
- The new operator must start in an area without bystanders and use all the controls until he or she can operate the machine safely under all conditions of the work area.

3. Safety

3.2 Operators Cont'd

Operator Safety

- Any use of the machine other than the intended use is a non-intended use and is considered to be unauthorized and dangerous. Blue Diamond® is liable for any damage or injury resulting from non-intended use.
- Before starting, and during operation of the attachment, make sure there are no people or animals in the operation area; the machine can project material from the back with risks of serious injury or death.
- During operation, adjustment, maintenance, repairing, or transportation of the machine, the operator must always use appropriate Personal Protective Equipment (PPE) including but not limited to safety glasses, working gloves, dust mask, safety helmet, and hearing protection.
- Do not operate the attachment or machine while wearing loose fitting clothing that can be entangled or caught in parts of the machine.
- Do not operate the implement when tired, not in good condition, or under the influence of alcohol or drugs.

3.3 Safety Guidelines

Operating Safety

- Read and follow instructions in this manual and the machine's Operator's Manual before operating.
- Under no circumstances should young children be allowed to work with this equipment.
- This equipment is dangerous to persons unfamiliar with its operation.
- Check for overhead and/or underground lines before operating equipment.
- In addition to the design and configuration of equipment, hazard control and accident prevention are dependent upon the awareness, concern, prudence, and proper training of personnel involved in the operation, transport, maintenance, and storage of

equipment.

- Check that the attachment is securely fastened to the machine.
- Make sure all the machine controls are in the NEUTRAL before starting the machine.
- Operate the equipment only from the operator's position.
- Operate the equipment according to the Operator's Manual.
- When learning to operate the equipment, do it at a slow rate in an area clear of bystanders.
- Do not permit personnel to be in the work area when operating the equipment.
- Do not permit personnel to be in the work area when operating the equipment.
- The equipment must be used ONLY on approved machines.
- Do not modify the equipment in any way. Unauthorized modification may impair the function and/or safety and could affect the life of the equipment.
- Do not make any adjustments or repairs on the equipment while the machine is running.
- Keep shields and guards in place. Replace if damaged.
- DO NOT operate equipment in poor visibility conditions such as fog, darkness, or any conditions that limit clear visibility less than 300 feet (100 m) in front of and to the sides of the equipment.
- Do not allow anyone to climb or ride on a drill mast, planetary drive, auger bits, or auger extensions at any time, including while stationary, in operation, or being moved/rotated.
- DO NOT operate in a work area that has not been inspected for foreign debris and obstacles.
- Remove any foreign objects and clearly mark any objects that cannot be removed.
- Open bore holes must be capped and flagged.

3. Safety

3.3 Safety Guidelines Cont'd

Operating Safety Cont'd

- Drilling must be stopped in the event of local thunderstorms or lightning activity.
- All rotating parts must be stopped before adding or removing bits and extensions.
- Know the capabilities of your equipment and practice its operation to become familiar with the controls, emergency shut down procedures, and the way it handles your machine.
- Wear safety glasses, gloves, hearing protection, and other protective clothing when required.
- At the completion of the useful life of the unit, drain all fluids and dismantle by separating the different materials (rubber, plastic, steel, etc.). Follow all federal, state, and local regulations for recycling and disposal of the fluid and components.

Machine Requirements and Capabilities

- The machine's operator's cab should be equipped with a thermoplastic polycarbonate or similar material front window, and similar protection on the sides of the operator's cab before operating the equipment.
- Augers shall be used only for their designed intent and shall not be loaded beyond their rated capacity. Overloading and exceeding the specifications dictated in this manual will void the warranty.
- Keep bystanders clear of moving parts and the work area. Keep children away.
- Do not exceed maximum operating pressure. See "8.1 Attachment Specifications" on page 46 for more information.
- Use caution on slopes and near banks and ditches to prevent overturn.
- Travel only with the Auger in a safe transport position, such as tethering any auger bits and extensions connected to the drive with a chain, to prevent uncontrolled movement.

Fire Prevention Safety

- Flammable debris (leaves, grass, etc.) must be removed regularly. If flammable debris is allowed to accumulate, it can cause a fire hazard. Clean often to avoid this accumulation.
- The equipment's motor compartment must be inspected every day and cleaned if necessary to prevent fire hazards and overheating.
- All fuels, most lubricants, and some coolant mixtures are flammable. Flammable fluids that are leaking or spilled onto hot surfaces or onto electrical components can cause a fire.
- Remove paint before welding or heating. Hazardous fumes/dust can be generated when paint is heated by welding, soldering, or using a torch. Do all work outside or in a well ventilated area and dispose of paint and solvent properly. When sanding or grinding paint, avoid breathing the dust. Wear an approved respirator. If you use a solvent or paint stripper, remove the stripper with soap and water before welding. Remove solvent or paint stripper containers and other flammable material from the area. Allow fumes to disperse at least 15 minutes before welding or heating.

Transporting Safety

- Comply with state and local laws governing highway safety and movement of machinery on public roads.
- Check local laws for all highway lighting and marking requirements.
- Always yield to oncoming traffic and move to the side of the road so any following traffic may pass.
- Never allow riders on either machine or equipment.
- If transporting the equipment on a truck or trailer, make sure the equipment is properly secured to the transport vehicle.

3. Safety

3.3 Safety Guidelines Cont'd

Hydraulic System

- Check hydraulic tubes, hoses, and fittings for damage and leakage. Never use open flame or bare skin to check for leaks. Hydraulic tubes and hoses must be properly routed and have adequate support and secure clamps. Tighten or replace any parts that show leakage.
- Always clean fluid spills. Do not use gasoline or diesel fuel for cleaning parts. Use commercial nonflammable solvents.
- Flow and pressure gauges, fittings, and hoses must be at a continuous operating pressure rating of at least 25% higher than the highest pressures of the system.
- This attachment is equipped with a hydraulic motor, which requires oil to be of suitable cleanliness. Ensure the hoses are clear of any contamination during connecting and disconnecting to prevent contaminants entering the hydraulic motor.

Storage Safety

- Seal the hydraulic quick couplers from contaminants and secure all hydraulic hoses off the ground to help prevent damage.
- Clean the unit thoroughly, removing all mud, dirt, and grease.
- Inspect for visible signs of wear, damage, or breakage. Contact Blue Diamond® Product Support for ordering any parts required, and make necessary repairs to avoid delays upon removal from storage.
- Check that the drive unit motor and hoses are full of clean oil and the planetary drive is full.
- Liberally coat the following parts with grease to prevent rust and reduce wear: output shaft and collar, extension shaft and collar, and all connecting pins.
- Tighten loose nuts, cap screws, and hydraulic connections.
- Replace missing or damaged safety decals.

- Store in a dry, sheltered place not frequented by children. Leaving the attachment outside will materially shorten its life. See “5.10 Storage” on page 27 for further information.

Personal Protective Equipment



Proper Work Clothes: To help ensure your safety as a designated operator wear proper work clothes including tight fitting clothes, protective gloves, and shoes.



Hand Protection: To help ensure your safety as a designated operator wear protective gloves.



Protective Shoes: To help ensure your safety as a designated operator wear protective shoes.



Safety Helmet: To help ensure your safety as a designated operator wear a safety helmet.



Safety Helmet and Eye/Ear Protection: To help ensure your safety as a designated operator wear a safety helmet and eye/ear protection.

4. Operation

4.1 Pre–Operation Inspection

Before operating the Mini Auger for the first time and each time thereafter, use the following list as a guideline during equipment inspection.



WARNING



AVOID SERIOUS INJURY OR DEATH

- Disengage machine’s auxiliary hydraulics, engage the machine’s parking brake, stop the engine, and make sure all moving parts are completely stopped before connecting, disconnecting, adjusting, or cleaning equipment.
- Always keep shields and guards in place when using the equipment.
- Disengage machine’s auxiliary hydraulics for road travel.
- Keep hands, feet, and clothing away from rotating parts.

- Inspect the attachment for shipping damage. If damage does exist, do not operate until the damaged parts have been replaced or repaired.
- Lubricate the attachment per the schedule outlined in the Maintenance section. See “5.1 Service Schedule” on page 19 for more information.
- Check the attachment mounting frame for damage or cracks.
- Check that all shields and guards are in place.
- Check for loose hardware (i.e. nuts, bolts, screws, etc.) and tighten them if necessary.
- Check all welds on the attachment for wear and damage each time the attachment is removed from the machine.
- Check for damaged or missing safety decals. Replace if necessary.
- Inspect the machine’s mounting frame. (See the machine’s Operator’s Manual for inspecting the mounting frame.) Replace any parts that are damaged, bent, or missing. Keep all fasteners tight. Look for cracked welds.

- Verify that the attachment is properly connected to the machine.



WARNING



Leaking fluids under pressure can enter the skin and cause serious injury or death. Immediate medical attention is required. Wear goggles. Use cardboard to check for leaks.

- Check the condition of all hydraulic components for leaks. Repair as required.
- NOTE:** Do not operate with hydraulic leaks.
- Make sure all pivot pins are well lubricated and the gimbal is moving freely. Re–grease if required.
 - Check for wear and tear on pins, linkages, cutting edges and replace any damaged and/or excessively worn parts.
 - Use only Blue Diamond® recommended replacement parts. Other parts may be substandard in fit and quality.
 - Ensure any damage or excessively worn parts are replaced.
 - Always wear safety goggles or glasses when inspecting equipment.

4. Operation

4.2 Setup Procedure



Before the Mini Auger is connected to the host machine, ensure that the drive is full of hydraulic oil and the gearbox is full of gear oil.

All Blue Diamond® Mini Augers are shipped full of fluids (hydraulic and gearbox oil) unless specified otherwise in the form of a warning decal attached to the drive unit.

The decal is only applied in special circumstances, i.e. the attachment is shipped via air freight.

Once determined if the gearbox is sufficiently filled with oil, ensure the correct grade and quantity of oil is used. **DO NOT** run the drive unit without oil. Connect the hydraulic hoses.

The Mini Auger drive uses ISO EP 320 (Mineral Oil) for operating in tropical ambient temperatures. See “5.3 How to Check the Gearbox Oil Level” on page 21 for procedures on how to check the oil level of the gearbox as well as the gearbox oil recommended for cold climate conditions.

See “5.5 How to Change or Refill the Gearbox Oil” on page 22 for gearbox volume and check and topping off the gearbox oil.

NOTE: To ensure the best motor life, run the motor for approximately one (1) hour at 30% rated pressure before application to full load. Be sure that the motor and gearbox are full of fluids prior to any load application.

NOTE: When procuring any hose assemblies for use on your Blue Diamond® Auger Drive, ensure that the maximum operating pressure of the hoses is always 25% higher than what the host machine can produce.

NOTE: Never exceed the maximum flow and pressure ratings as it might void the warranty.

4.3 Entering & Exiting the Prime Mover



See the machine’s Operator’s Manual for detailed information on operating the loader.

Entering the Operator’s Position

Use the safety treads, handles, and steps on the attachment and machine to enter the operator’s position. Always maintain three (3) points of contact.

When in the operator’s position, face forward and grip the handles. Place both feet on the rear operator platform to engage the operator presence system, start the engine, and release the parking brake.

Leaving the Operator’s Position



AVOID SERIOUS INJURY OR DEATH

- Always park on a flat, level surface.
- Lower lift arms and place attachment flat on the ground.
- Place all controls in **NEUTRAL**.
- Engage the parking brake.
- Stop the engine, and remove the key.
- Wait for all moving parts to stop.

SEE MACHINE’S OPERATOR’S MANUAL FOR ADDITIONAL INFORMATION.

Park the machine/attachment on a flat, level surface.

Place all controls in neutral, engage the parking brake, stop the engine, and wait for all moving parts to stop. Leave the operator’s position.

4. Operation

4.4 Attachment Installation

Connecting Attachment to the Machine



WARNING



CRUSH HAZARD

- Before moving the machine, look in all directions and make sure no bystanders, especially small children are in the work area. Do not allow anyone between the machine and attachment when approaching the attachment for connecting.
- Keep fingers and hands out of pinch points when connecting and disconnecting the attachment.

Before connecting to the attachment, inspect the machine's mounting plate. (See the machine's Operator's Manual for inspecting the mounting frame.)

Enter the operator's position. See "Entering the Operator's Position" on page 13.

Drive the machine slowly forward until the top edge of the machine's mounting plate is under the top flange of the attachment mounting frame.

Slowly tilt the machine's mounting plate back until the attachment mounting frame fully contacts the front of the machine's mounting plate.

Leave the operator's position. See "Leaving the Operator's Position" on page 13.



WARNING



AVOID SERIOUS INJURY OR DEATH

The locking pins/wedges must extend through the holes in the attachment mounting frame. Failure to secure locking pins/wedges can allow attachment to come off.

SEE MACHINE'S OPERATOR'S MANUAL FOR ADDITIONAL INFORMATION.

Engage attachment locking levers/wedges (See the machine's Operator's Manual for detailed information.)

Connecting Hydraulic Hoses



IMPORTANT



Thoroughly clean the quick couplers before making connections. Dirt can quickly damage the hydraulic system.

Verify that all hydraulic couplings are compatible with the host machine.

Remove dirt or debris from the male and female couplers. Visually inspect the couplers for corroding, cracking, damage, or excessive wear. Replace as needed.

Connect the attachment hydraulic hoses to the machine. The hydraulic hoses must be connected in the following order: return hose then pressure hose.

Pull on each hose to verify full connection is made.

Disconnecting Hydraulic Hoses



WARNING



AVOID SERIOUS INJURY OR DEATH

Hydraulic fluid, tubes, fittings, and quick couplers can get hot during operation. Be careful when connecting and disconnecting hydraulic hoses.

Relieve auxiliary hydraulic pressure. (See the machine's Operator's Manual for correct procedure.)

Disconnect attachment hydraulic hoses from the machine. The hoses must be disconnected in the following order: pressure hose then return hose. The pressure hose must be disconnected before the return hose.

4. Operation

4.4 Attachment Installation Cont'd

Disconnecting Attachment From the Machine

Relieve auxiliary hydraulic pressure. (See the machine's Operator's Manual for correct procedure.)

Park the machine and attachment on a flat, level surface. Lower the attachment flat on the ground.

Leave the operator's position. See "Leaving the Operator's Position" on page 13.

Disconnect attachment hydraulic hoses from the machine.

Disengage locking pins/wedges. (See the machine's Operator's Manual for correct procedure.)

Enter the operator's position. See "Entering the Operator's Position" on page 13.

Slowly tilt the machine's mounting plate forward until the attachment mounting frame is free from the machine's mounting plate.

Drive the machine slowly backward, away from the attachment.

4.5 Installing Bits & Extensions to the Auger Drive

Before connecting the bit and/or extension to the Auger, make sure that the auger teeth and pilots are not worn. Ensure all worn parts are replaced. Worn parts will become ineffective and severely diminish the overall performance of the attachment.

1. Lay the attachment down until it is parallel with the ground.
2. Tilt the auger drive up so the output shaft is at the approximate angle needed to install the auger bit or extension. See Figure 1.

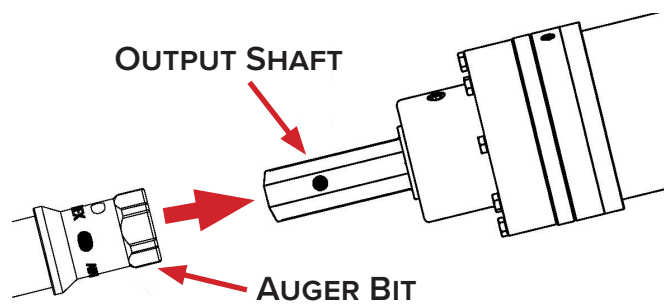

Figure 1

3. Raise the Auger, and line the pin holes in the bit or extension and the output shaft. Slide the bit/extension onto the shaft until the holes are aligned. See Figure 2.

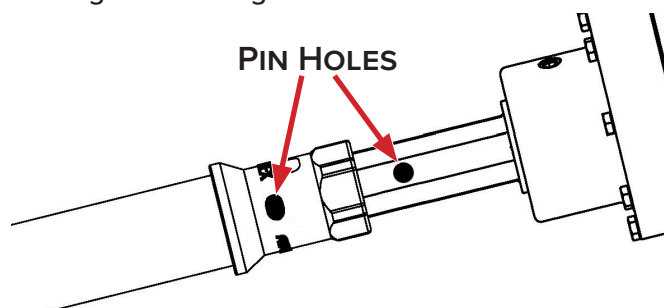

Figure 2

4. Insert the bolt through the auger bit/extension and through the output shaft. Tighten the nut per torque values on page 47. See Figure 3.

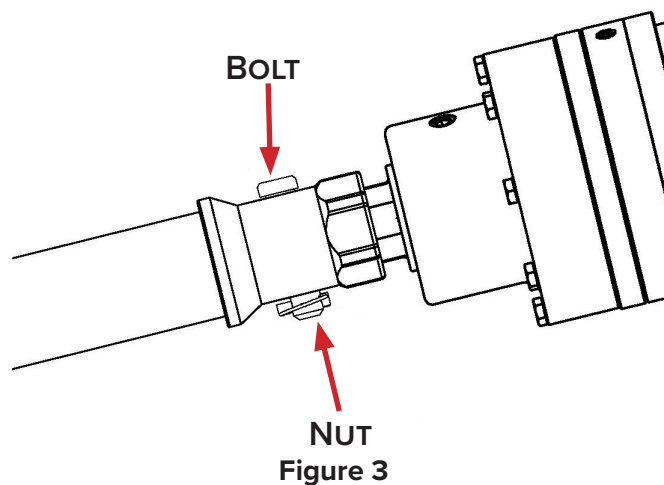

Figure 3

4. Operation

4.6 Cold Weather Startup Information

The information that is in this section is an aid to the operation and maintenance of your Blue Diamond® Mini Auger in cold weather. When operating in temperatures from 48°F to -40°F (9°C to -40°C), refer to the host machine's Operator's Manual for best practices.

Be sure to read the information for selecting the correct oils for use in cold weather. Refer to "Severe Operating Conditions" on page 20 for more information. Prepare the host machine for weather conditions as instructed in the machine's Operator's Manual.

Blue Diamond's Mini Auger is designed to operate within air temperature of 41°F and 86°F (5°C and 30°C).

For temperatures below 41°F (5°C), it is recommended to slowly start the drive under no load at minimum speed. This will allow warm hydraulic oil to circulate through the hydraulic motor of the drive and slowly bring it to the minimum recommended operating temperature of 41°F.

Once the minimum temperature has been achieved, slowly introduce load to the output of the drive unit, which, in turn, will increase the internal gear oil temperature.

The host machine's cooling system and lubrication system for the engine do not lose heat immediately upon shutdown. The transmission and hydraulic system lose heat more rapidly because of more exposed areas. The planetary gearbox and motor cases cool rapidly, since the cases do not operate as warm as other compartments. Therefore, after any period of down time on the machine, be sure to achieve full operating temperatures through the following startup instructions. Thick oil can cause high case pressures, which can result in shaft seal problems.

4.7 Operating the Attachment



The Mini Auger Drive is specifically designed for drilling and rotational operation only. Do not use the attachment for lifting purposes.

This attachment is designed for drilling vertical or horizontal holes or rotating piers into the ground. Use in any other way is considered contrary to the intended use and poses a significant risk of voiding the warranty.

After all installation instructions have been completed, all information in 3. Safety has been read and understood, and the rest of this operation and maintenance manual has been reviewed, the Mini Auger is now ready for use.

1. With the auger bit raised off the ground and the vehicle engine set at a low RPM, activate the host machine's drive control valve to determine which position the control valve lever must be in to turn the auger in a forward (clockwise) rotation. This is the "drilling" position.
2. Before beginning to drill, experiment with the auger speed to determine a suitable RPM. Generally in light and sandy soil, a high RPM is desirable. In hard, rocky, or frozen soils, a slower RPM is desirable. To increase auger RPM, increase the host machine's RPM. To decrease the auger RPM, decrease the host machine's engine RPM.
3. Raise the attachment so the auger bit stands vertically and the drive is clear of the cradle. Then lower the bit into the starting position.

NOTE: Be sure not to sideload the auger drive, meaning that the entire unit, drive, and bit/extension must be straight and not touch the cradle when in operation.

4. Operation

4.7 Operating the Attachment Cont'd

4. Ensure the mount plate on your machine is tilted forward and not back. This will keep the auger drive clear of the cradle and allow the bit to freely move from side to side, forwards, and backwards. The pendulum action must not be hindered otherwise damage and/or bending of the output shaft or bit may occur. Lower the bit into the ground, ensuring the drive does not stall and remains in the vertical position, start the rotation of the Mini Auger.
5. As the bit starts to load up the material (soil, rock, sand, etc.), stop the rotation whilst still in the hole, and raise the bit vertically. Move away from the hole, and rotate the Mini Auger in a forward direction to remove the material.
6. If experiencing strong resistance while trying to remove the bit when it is full of material, slowly reverse the Mini Auger while vertically raising the bit to assist with removal. Do not use the host machine to pull as this increases the risk of bending the output shaft.
7. Regularly clear the hole during operation. This will help prolong the life of the attachment as well as wear parts.

NOTE: Blue Diamond® recommends adding a slow stream of water when drilling rock to help the performance and life of the rock bit's teeth.

! IMPORTANT !

- **DO NOT** rapidly switch between forward and reverse operation to remove material from the Mini Auger. This creates excessive pressure spikes, which will adversely affect performance and longevity of the motor.
- Do not remove the bit from the hole while at an angle. This will increase the risk of bending the auger bit or output shaft.
- Do not flick material, especially mud or clay, from the bit as this increases the risk of bending the output shaft.

4.8 Operating Positions

Drilling Position

Ensure the vertical position is maintained when drilling.

DO NOT drill with the cradle resting against the drive unit. This is known as sideloading and will damage the drive unit and the auger. See Figure 4.

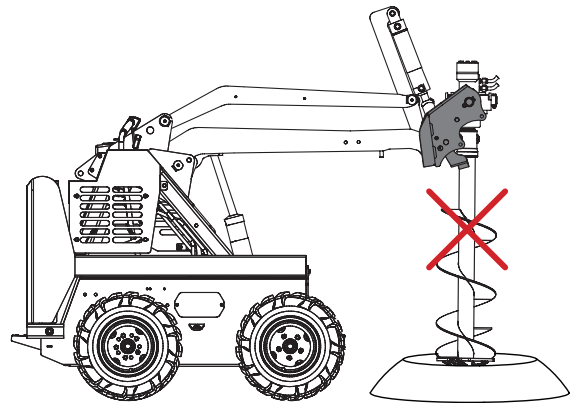

Figure 4

The correct drilling operation is with the cradle positioned up and away from the drive unit, allowing the drive and auger to freely swing in whatever direction the drive unit is equipped for. See Figure 5.

The 2-way swing model should freely move forward and backward.

The 4-way swing model should freely move forward and backward as well as left and right.

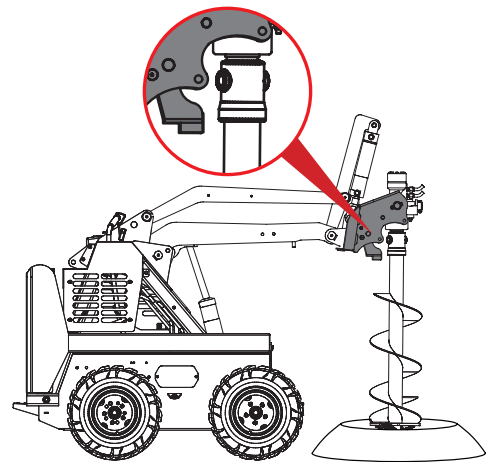

Figure 5

4. Operation

4.8 Operating Positions Cont'd

Travel Position

For maneuvering around the work area, the cradle must be positioned so that the drive is resting against the cradle and the machine's loader arms are not obstructing visibility. See Figure 6.

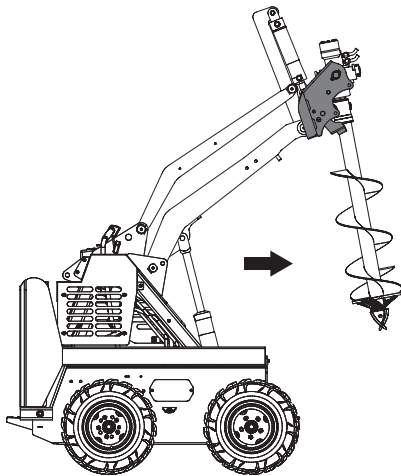

Figure 6

5. Maintenance

5.1 Service Schedule

DESCRIPTION	SERVICE PROCEDURES					
	Check	Clean	Lube	Change	Adjust	Drain
Daily Maintenance (or every 8 hours)						
Hydraulic Fittings	•					
Hydraulic Hoses	•					
Bits (teeth, retaining bolt, etc.)	•	•				
All Hardware	•					
Weekly Maintenance (or every 40 hours)						
All Hardware	•					
Monthly Maintenance						
All Hardware	•					
500 Hour Maintenance						
Gear Oil*				•		

*See “5.2 Gear Oil Change Schedule” on page 20 for additional information.

5. Maintenance

Proper and regular maintenance ensures a long life of the attachment, avoids failures, and saves time and repair costs.

Periodic inspections and maintenance operations described in this section must be performed by an operator in times and terms prescribed. Failure to comply with maintenance prescriptions can compromise the function and lifetime of the attachment, which will result in the warranty becoming void.

Repairs, maintenance, and modifications other than those mentioned in this manual should NOT be performed without consulting Blue Diamond® Product Support.

Wrong or inappropriate repairs or maintenance may generate abnormal operating conditions, equipment damage, and generate risks for the operator.



WARNING



AVOID SERIOUS INJURY OR DEATH

The following must always be performed prior to any adjustment being made:

- Always park on a flat, level surface.
- Lower lift arms, and place attachment flat on the ground.
- Place all controls in NEUTRAL.
- Engage the parking brake.
- Stop the engine, and remove the key.
- Wait for all moving parts to stop.
- Set the parking stand.

SEE MACHINE'S OPERATOR'S MANUAL FOR ADDITIONAL INFORMATION.

5.2 Gear Oil Change Schedule

Blue Diamond® recommends Chevron Meropa ISO 32 Mineral Oil for gear oil. Minimum operating temperature is 16°F (–9°C), and the maximum operating temperature is 248°F (120°C).

If operating in weather conditions below 41°F (5°C), see “4.6 Cold Weather Startup Information” on page 16.

Moderate Operating Conditions

- The first oil change must occur after the first 50 hours of use or within the first three months of use, whichever occurs first.
- After the initial oil change, the oil will need changed every 500 hours of operation or once every 12 months, whichever comes first.

Severe Operating Conditions

- When environment temperature is below 32°F (0°C) or above 104°F (40°C) or the Mini Auger is being used in hard ground or for extended and continuous hours, this is considered Severe Operating Conditions.
- The first oil change must occur after the first 30 hours of operation.
- After the initial oil change, the oil will need changed every 300 hour of operation or once every 12 months, whichever comes first.

MODEL NUMBER	OIL CAPACITY	RECOMMENDED OIL
105700	0.48 Quarts (0.45 Liters)	EPG320 Mineral Oil
105702		

5. Maintenance

5.3 How to Check the Gearbox Oil Level

Unfortunately there is no procedure to quickly inspect the gearbox oil level. The gearbox is filled to the correct level during manufacturing.

Unless there are clear signs of gearbox oil leakage, the attachment should not require additional oil prior to scheduled oil changes and/or services.

5.4 How to Drain Gearbox Oil

The gearbox oil change interval should be carried out in accordance with the requirements set out in “5.2 Gear Oil Change Schedule” on page 20. Blue Diamond® recommends replacing the output shaft seal during the initial oil change as this is the most important oil change to prolong the life of bearings and gears. This is because gearboxes can generate fine, metallic contamination, which will find its way to the lowest part of the gearbox and collect in the output seal. This abrasive paste will wear the output seal and also the output shaft. It is advisable that the oil changes are performed by a local Blue Diamond® authorized dealer. If one is not available, it is more important that the oil is changed at the required intervals.

Follow all local, state, and federal laws when disposing of oil.

1. Ensure that the gearbox is stable, secure, and safe to work on prior and that the drive unit is vertical and that there is an appropriate sized drip tray to catch the drained oil.
2. Before draining any oil, check the serial tag of the unit to determine the quantity of oil which the gearbox holds. This will indicate the quantity of oil which has to be replaced into the gearbox and size of bucket needed to contain the oil.

Remove the drain plug from the output housing. This will allow the bulk of the gearbox oil to drain out (this will not drain the gearbox entirely). The lower section of the output housing, below the plug, will still contain some oil.

3. To drain the remaining oil, see “2-Way Swing Model” on page 21 or “4-Way Swing Model” on page 22 depending on the model you own.

Alternatively, the remaining oil, regardless of model, can be drained by removing the output shaft seal.

2-Way Swing Model

The drive unit can either be left in the frame and the whole frame can be tilted or the drive unit can be removed from the frame in order to drain the gearbox oil.

1. To remove the drive unit from the frame, remove the two (2) M10 x 60 mm long bolts and nylock nuts. See Figure 7, Item 1.

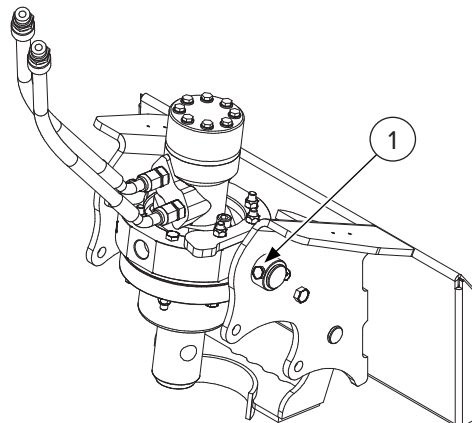

Figure 7

2. Remove the two (2) pivot pins. Clean the pins and housings. Apply a multi-purpose grease.
3. Remove the 1/4” BSP drain plug using an Allen key. See Figure 8, Item 1.

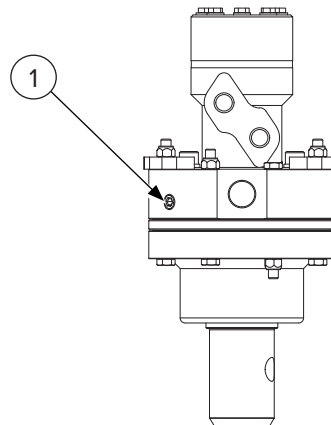

Figure 8

5. Maintenance

5.4 How to Drain Gearbox Oil Cont'd

2-Way Swing Model Cont'd

4. Tilt the drive to drain the gear oil.
5. Refer to “5.5 How to Change or Refill the Gearbox Oil” on page 22.
6. To reassemble, perform the previous steps in reverse.

4-Way Swing Model

The drive unit will have to be removed from the frame in order to drain the gearbox oil.

1. To remove the drive unit from the frame, remove the four (4) M10 x 60 mm long bolts and nylock nuts. See Figure 9, Item 1.

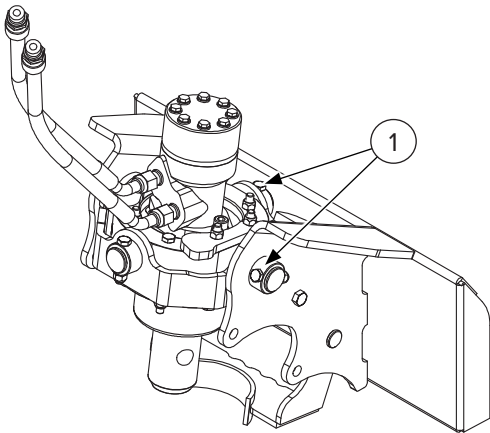

Figure 9

2. Remove the four (4) pivot pins. Clean the pins and housings. Apply a multi-purpose grease.
3. Remove the 1/4" BSP drain plug using an Allen key. See “Figure 8” on page 21.
4. Remove the drive unit from the frame to drain the gearbox oil.
5. Refer to the “5.5 How to Change or Refill the Gearbox Oil” on page 22.
6. To reassemble, perform the previous steps in reverse.

5.5 How to Change or Refill the Gearbox Oil

Make sure to use the correct oil. See “5.2 Gear Oil Change Schedule” on page 20.

1. Lay the drive unit flat on the ground with the oil fill plug facing up. Using an 8 mm Allen key, remove the plug. See Figure 10.

To drain the oil, turn the drive until the hole is facing down. Allow to drain until all oil has been removed.

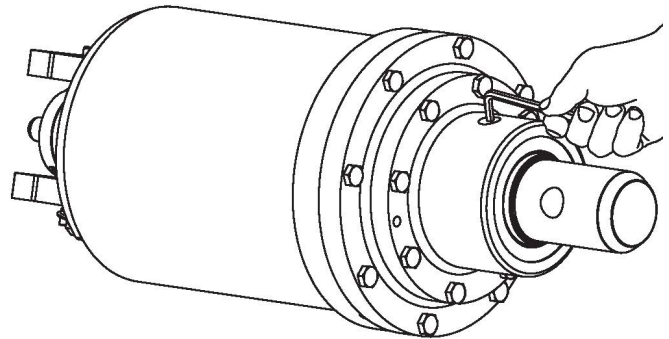

Figure 10

2. Rotate the unit until the oil fill hole is sitting between 60° and 70° from horizontal. See Figure 11.

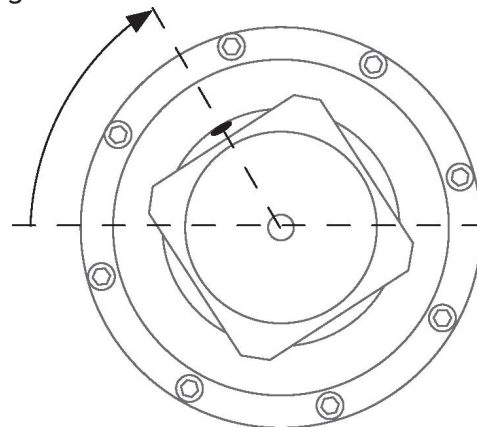

Figure 11

5. Maintenance

5.5 How to Change or Refill the Gearbox Oil Cont'd

3. Once the oil fill hole is at approximately 60°, the oil should be sitting at the base of the oil fill hole. See Figure 12.

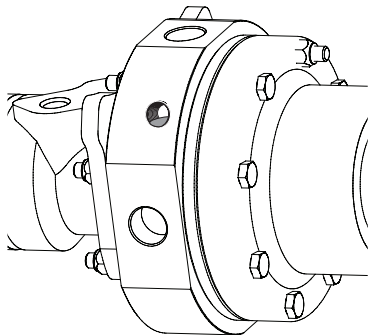

Figure 12

4. If the oil level is too low to reach the thread, it should be topped off. Rotate the unit so the oil fill hole is sitting at the top, and add oil.

Repeat steps 2 – 4 until the correct level is achieved.

NOTE: The oil takes time to work its way through the gearbox. Allow time for it to settle once it has reached the oil fill hole. Then check the level again until all seepage has occurred.



If the auger is leaking oil after performing the daily checks, contact Blue Diamond® Product Support or a local authorized dealer.

5.6 Output Shaft Seal Replacement

Perform the following steps to replace the output shaft seal:

1. Use a sharpened punch to remove the output shaft seal. See Figure 13.

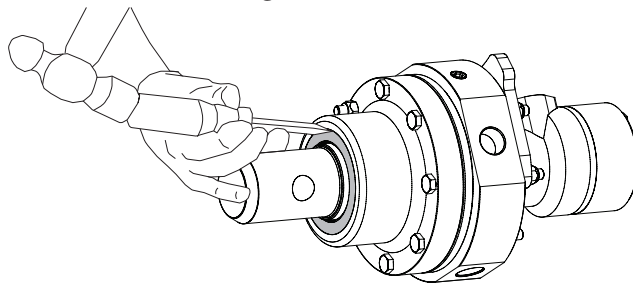

Figure 13

2. Clean the area where the shaft seal sits [Figure 14]. It is recommended to clean the surface area with an alcohol-based cleaner.

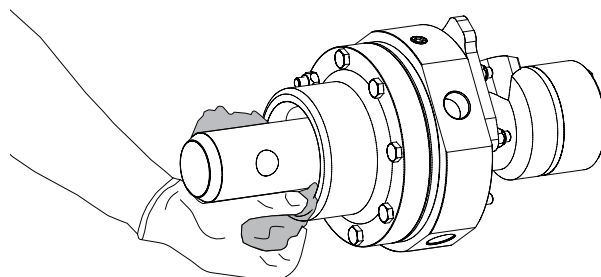

Figure 14

3. Smear multi-purpose grease to the inside of the new output shaft seal [Figure 15].

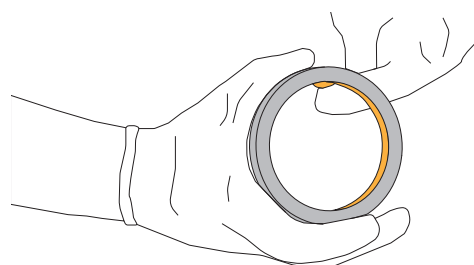

Figure 15

5. Maintenance

5.6 Output Shaft Seal Replacement Cont'd

4. Add threadlocker medium strength (i.e. Loctite 243) around the outside of the shaft seal [Figure 16].

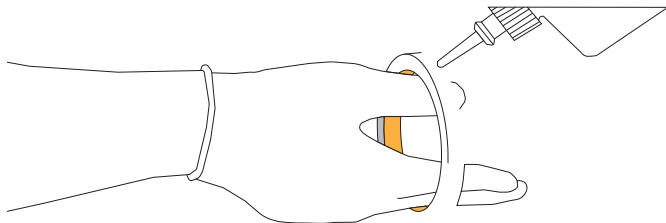

Figure 16

5. Insert the new shaft seal and tap it into place with a hammer and a piece of nylon or brass until the seal is flush with the housing [Figure 17].

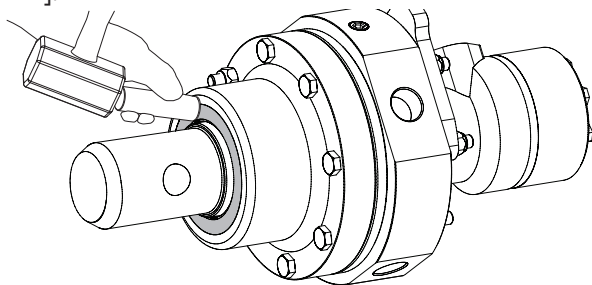

Figure 17

5.7 How to Replace Teeth on Auger Bits



WARNING



AVOID SERIOUS INJURY OR DEATH

- Always wear safety glasses and other appropriate personal protective equipment (PPE), such as gloves, when replacing teeth on auger bits due to risk of flying objects.

Position the bit so that the bottom is easily accessible. Ensure it is firmly secured to prevent injury and/or damage to the equipment. See Figure 18.

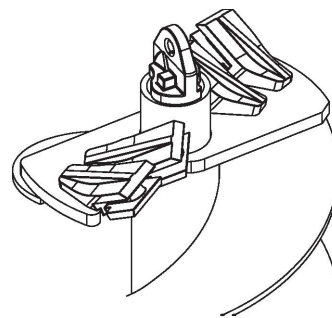

Figure 18

Pilot/Fishtail

1. Remove the nut and bolt from the pilot/fishtail. Then remove the pilot.
2. Clean the bit.
3. Place the new pilot on the bottom of the bit, and secure with the nut and bolt. See Figure 19.

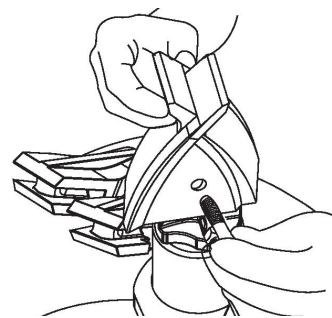

Figure 19

5. Maintenance

5.7 How to Replace Teeth on Auger Bits Cont'd

Cast Head Teeth

1. To remove the old tooth, place a pin punch at the back of the tooth.
2. Using a hammer or a mallet, tap the punch until the tooth is removed.
3. Clean the tooth holder.
4. Place the rubber locking strip into the tooth holder with the fold facing out. See Figure 20 and Figure 21.



Figure 20



Figure 21

5. Place the tooth into the tooth holder, ensuring the tooth's cutting edge is facing the same direction as the pilot. See Figure 22.



Figure 22

6. Using a soft head mallet, drive the tooth in the holder until it is fully seated. If a soft mallet is not available, a piece of wood can be used between the tooth and the mallet. See Figure 23.



WARNING



AVOID SERIOUS INJURY OR DEATH

- DO NOT strike the tip of the auger tooth directly with a steel hammer. This can cause the hardened or tungsten carbide tip to shatter.



Figure 23

7. Repeat until all teeth are replaced as necessary.

5. Maintenance

5.7 How to Replace Teeth on Auger Bits Cont'd

Fab Head & Tree Bit Teeth

1. Using a wrench, loosen the bolt that is holding the worn tooth in place.
2. Once the bolt is removed, remove the worn tooth from the bit.
3. Clean the tooth holder.
4. Align the new tooth with the bolt hole.
5. Tighten the bolt to the torque specified in “8.2 Torque Specifications – Metric” on page 47.
6. Repeat until all teeth are replaced as necessary.

Rock Bit Teeth

1. Place a tooth removal tool in the groove of the tooth. Use a soft hammer to tap on the removal tool.

Alternatively, if not equipped with a removal tool, place a pin punch or center punch against the tooth at the back of the tooth holder, and drive the tooth out from behind.

2. Once the old tooth is removed, clean the tooth holder.
3. Place the rock bit tooth in the holder, and use a soft head mallet to tap it into place. The new tooth is in place when it is seated all the way back in the tooth holder.

Alternatively, if not equipped with a soft head mallet, place a piece of wood or pipe on the end of the tooth for protection against a regular hammer.

4. Make sure the tooth rotates with no resistance.
5. Repeat until all teeth are replaced as necessary.

5.8 Maintaining Auger Bits

The Auger Bit is a ground-engaging tool fitted with wear parts to drill holes. Therefore, the bit's teeth and pilot/fishtail must be checked regularly and replaced with new wear parts. Failure to do so will cause premature wear and damage to the auger pocket and flighting. This will substantially reduce the drilling performance of the auger bit.

Be sure to clean the auger bit after each use. If not cleaned, the dirt and dust can prevent rotation and cause premature wear.

5.9 Spare Parts & Accessories

To maintain safety, performance, and product reliability, Blue Diamond® recommends the use of genuine Blue Diamond® replacement parts for all repairs and service.

Genuine Blue Diamond® parts are specifically designed and tested for your attachment. These components include critical items, such as hydraulic motors, cylinders, and structural weldments.

Use of non-genuine parts for components identified as Blue Diamond® OEM may affect product performance and could void applicable warranty coverage.

To obtain replacement parts, contact Blue Diamond® Product Support with the following information:

- Type of attachment
- Serial number
- Part number and/or description of part(s) needed
- Quantity of part(s) needed

5. Maintenance

5.10 Storage

Storage

Sometimes it may be necessary to store your Mini Auger for an extended period of time. Below is a list of items to perform before storage.

- Make sure the hydraulic hose couplers are capped, plugged, or connected to each other to prevent contaminants
- Thoroughly wash the attachment before storing it for long periods, removing all mud, dirt, and grease.
- Inspect for visible signs of wear, damage, or breakage. Contact Blue Diamond® Product Support for ordering any parts required, and make necessary repairs to avoid delays upon removal from storage.
- Check that the drive unit motor and hoses are full of clean oil and planetary drive is full.
- Liberally coat the following parts with grease to prevent rust and reduce wear: output shaft and collar, extension shaft and collar, and all connecting pins.
- Tighten loose nuts, cap screws, and hydraulic connections.
- Check for loose hardware, missing guards, or damaged parts.
- Check for damaged or missing decals. Replace if necessary.
- Replace worn or damaged parts.
- Store in a dry, sheltered place not frequented by children. Leaving the attachment outside will materially shorten its life.

NOTE: In muddy conditions or to prevent the attachment from freezing to the ground, put the attachment on planks or blocks before removing the attachment from the machine.

Return to Service

After the Mini Auger has been in storage, it is necessary to follow a list of items to return the attachment to service.

- Check that the drive unit motor and hoses are full of clean oil and planetary drive is full.
- Connect and operate the attachment and check for correct function.
- Check for leaks. Repair as needed.

5. Maintenance

5.11 Troubleshooting

PROBLEM	CAUSE	SOLUTION
GENERAL		
No Rotation	Quick disconnect fitting(s) not engaged	Check quick disconnect fitting(s).
	Quick disconnect fitting(s) faulty	Replace faulty fittings.
	Hydraulic oil tank low	Fill oil tank to the maximum level.
	Hydraulic motor failure	Contact Blue Diamond® Product Support.
	Output shaft bearing failure	Contact Blue Diamond® Product Support.
	Planetary gear failure	Contact Blue Diamond® Product Support.
	Machine oil pump faulty	Refer to the machine's Operator's Manual.
Slow Rotation	Low oil flow	Check the machine's specifications.
	Drive unit too large for the machine	Contact Blue Diamond® Product Support.
	Hydraulic system too hot	See Hydraulic System Section.
Hood Leaking Oil	Hose(s) or fitting(s) leaking	Tighten or replace.
	Motor O-ring failure	Contact Blue Diamond® Product Support.
Output Shaft Leaking Oil	Oil seal failure	Contact Blue Diamond® Product Support.
	Hydraulic motor failure	Contact Blue Diamond® Product Support.
No Torque	Oil pressure too low	Check the machine's specifications.
	Drive unit too small for the machine	Contact Blue Diamond® Product Support.
	Hydraulic system too hot	See Hydraulic System Section.
Grinding or Loud Noise	Gearbox failure	Contact Blue Diamond® Product Support.
HYDRAULIC SYSTEM		
Oil Overheating	Oil pressure too low	Set relief valve to the machine's specifications.
	Restriction in line	Inspect and repair.
	Auger continually stalling	Limit down pressure.
	Drive unit too small	Contact Blue Diamond® Product Support.
	Machine too small	Fit the drive unit to a larger machine.
	Hydraulic oil tank low	Fill oil tank to maximum level.
	Insufficient oil capacity	Fit oil cooler.
BITS		
Slow Digging Speed	Worn teeth or pilot	Replace. (See "4.6 How to Replace Teeth on Auger Bits" on page 25.)
	Ground too hard	Contact Blue Diamond® Product Support.
	Low oil flow	Check the machine's specifications.
	Bit too large for drive unit	Fit larger drive unit.
	Machine too small	Fit drive unit to a larger machine.

**This page intentionally
left blank**

6. Parts

6.1 2-Way Swing Main Components

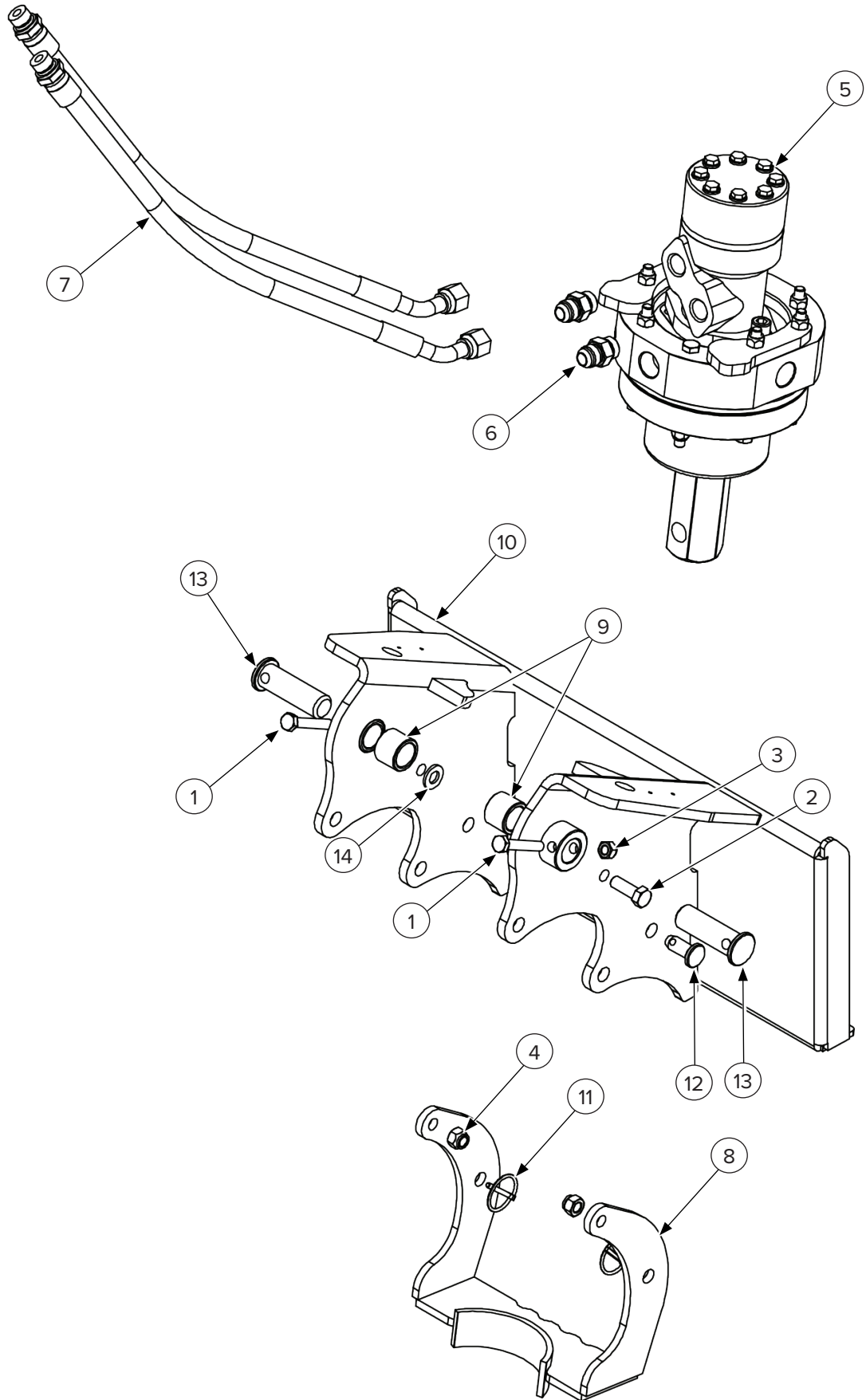

6. Parts

6.1 2-Way Swing Main Components Cont'd

ITEM	PART NUMBER	DESCRIPTION	QTY
1	—	M10 x 60 mm Hex Head Bolt Class 8.8 Zinc Plated	2
2	—	M12 x 35 mm Hex Head Bolt Class 8.8 Zinc Plated	2
3	299020	M10 Nylock Nut Class 8 Zinc Plated	2
4	—	M12 Nylock Nut Zinc Plated	2
5	—	Gearbox Assembly	1
6	—	Hydraulic Straight Fitting Male #14JIC 37° Flare Both Ends	2
7	—	Hose Assembly 63" OAL 3/8" ID with 45" Female #14 JIC Fitting to Straight Male #8 ORB	2
8	205761	Cradle	1
9	—	Floating Bushing	2
10	—	Frame	1
11	205763	Lynch Pin 5 mm Shaft	2
12	205764	Cradle Pin	2
13	—	Pivot Pin	2
14	—	M12 Washer Zinc Plated	2

6. Parts

6.2 4-Way Swing Main Components

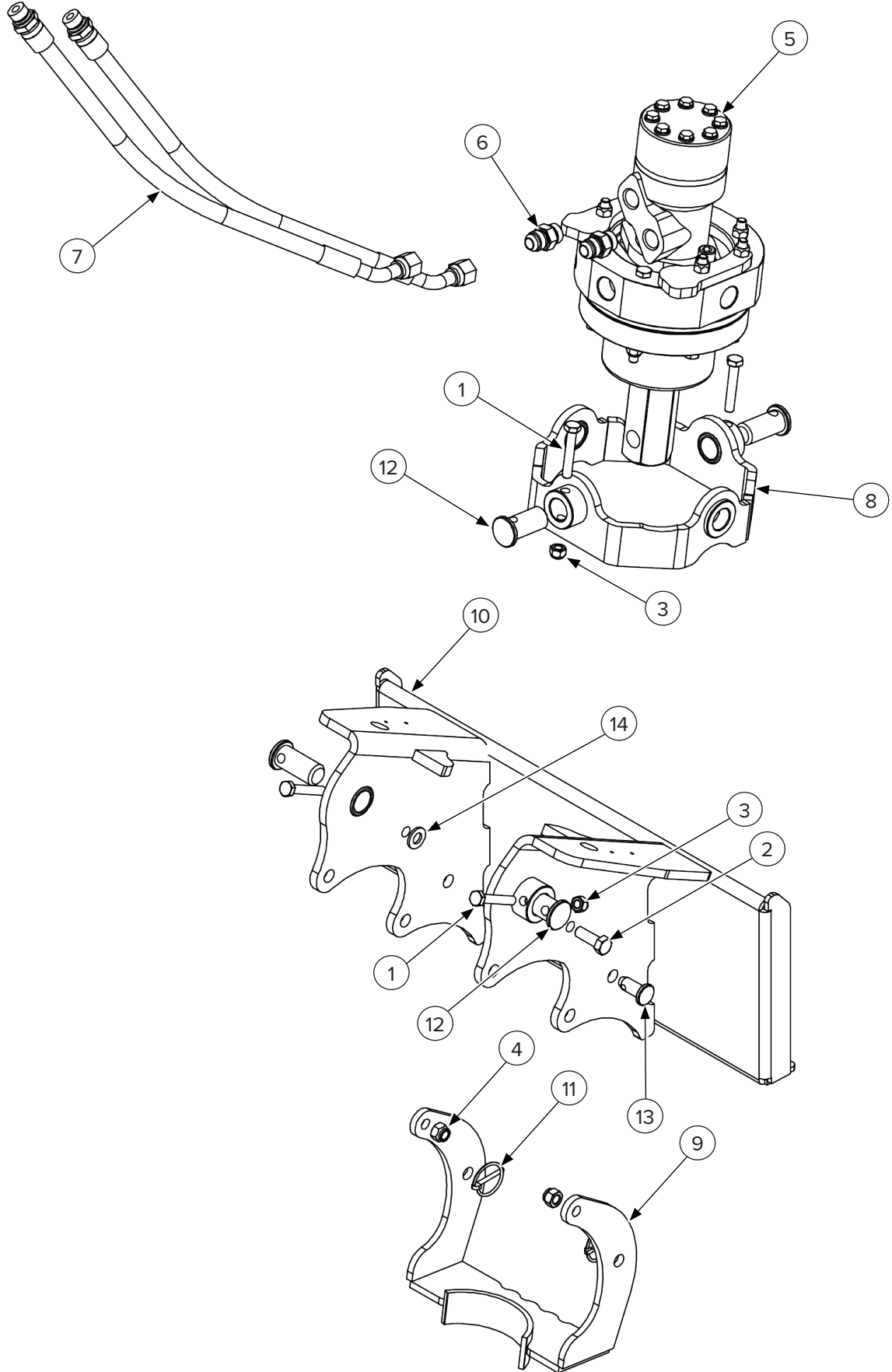

6. Parts

6.2 4-Way Swing Main Components Cont'd

ITEM	PART NUMBER	DESCRIPTION	QTY
1	—	M10 x 60 mm Hex Head Bolt Class 8.8 Zinc Plated	4
2	—	M12 x 35 mm Hex Head Bolt Class 8.8 Zinc Plated	2
3	299020	M10 Nylock Nut Class 8 Zinc Plated	4
4	—	M12 Nylock Nut Zinc Plated	2
5	—	Gearbox Assembly	1
6	—	Hydraulic Straight Fitting Male #14JIC 37° Flare on Both Ends	2
7	—	Hose Assembly 63" OAL 3/8" ID with 45" Female #14 JIC Fitting to Straight Male #8 ORB	2
8	—	Pivot Weldment	1
9	205761	Cradle	1
10	—	Frame	1
11	205763	Lynch Pin 5 mm Shaft	2
12	—	Pivot Pin	4
13	205764	Cradle Pin	2
14	—	M12 Washer Zinc Plated	2

6. Parts

6.3 Gearbox Components — Both Models

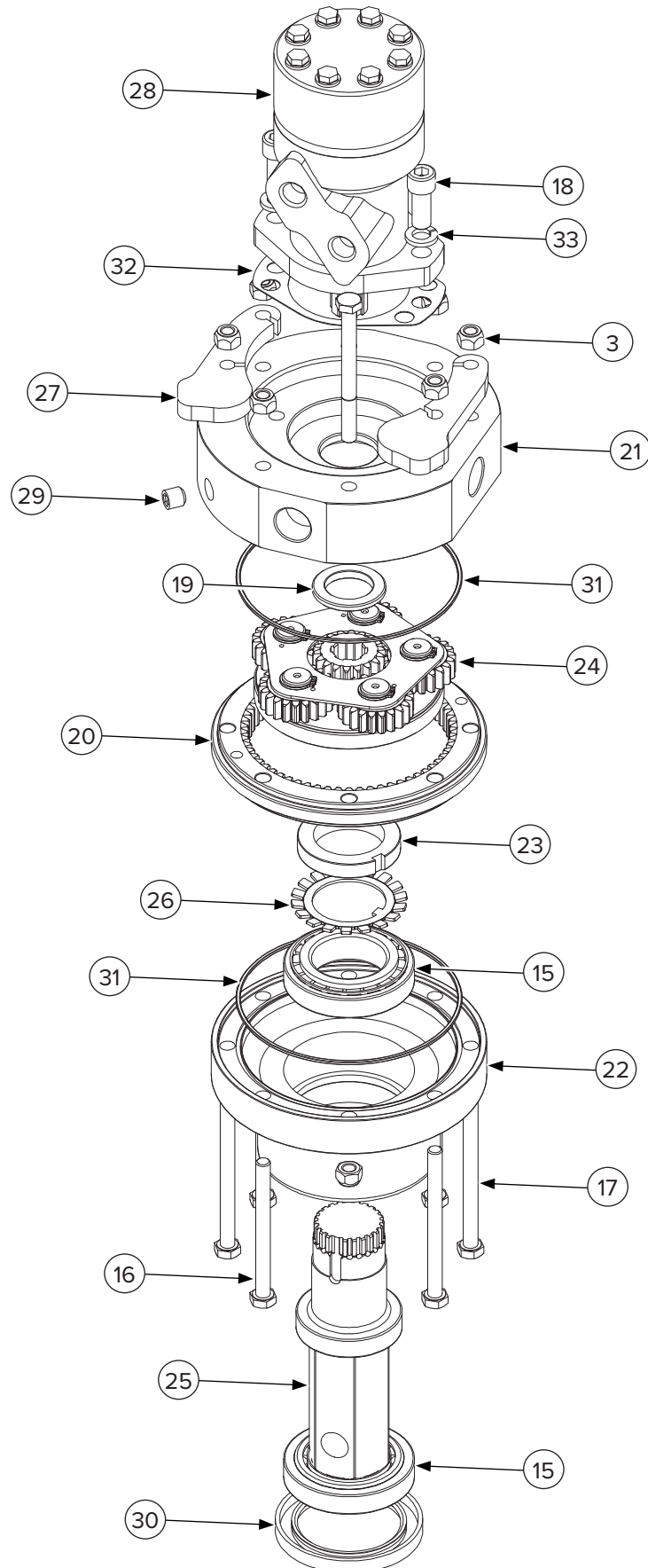

6. Parts

6.3 Gearbox Components – Both Models Cont'd

ITEM	PART NUMBER	DESCRIPTION	QTY
3	299020	M10 Nylock Nut Class 8 Zinc Plated	8
15	231306	Bearing Tapered Roller	2
16	299014	M10 x 110 mm Hex Head Bolt Class 8.8 Zinc Plated	4
17	—	M10 x 120 mm Hex Head Bolt Class 8.8 Zinc Plated	4
18	—	1/2"–13 x 1 1/4" Socket Head Cap Screw Grade 10 Zinc Plated	2
19	—	Thrust Washer	1
20	—	Ring Gear	1
21	—	Input Housing	1
22	—	Output Housing	1
23	—	Locknut with Built-In Spacer	1
24	—	Gearset Ration 4.4	1
25	—	2" Hex Output Shaft	1
26	205608	Gearbox Locking Tab – Shaft – S2 Bent	1
27	—	Gearbox Pivot Stop Lug	1
28	—	Hydraulic Motor	1
29	—	Pressure Plug 1/4" BSP	1
30	205775	72 mm x 100 mm x 10 mm Planetary Output Shaft Seal	1
31	231307	Planetary O-Ring	2
32	—	Gasket for Motor	1
33	299731	1/2" Lock Washer Zinc Plated	2

6. Parts

6.4 Safety Decals

***THESE DECALS
ARE PLACED ON
THE BACK OF THE
MOUNT.**

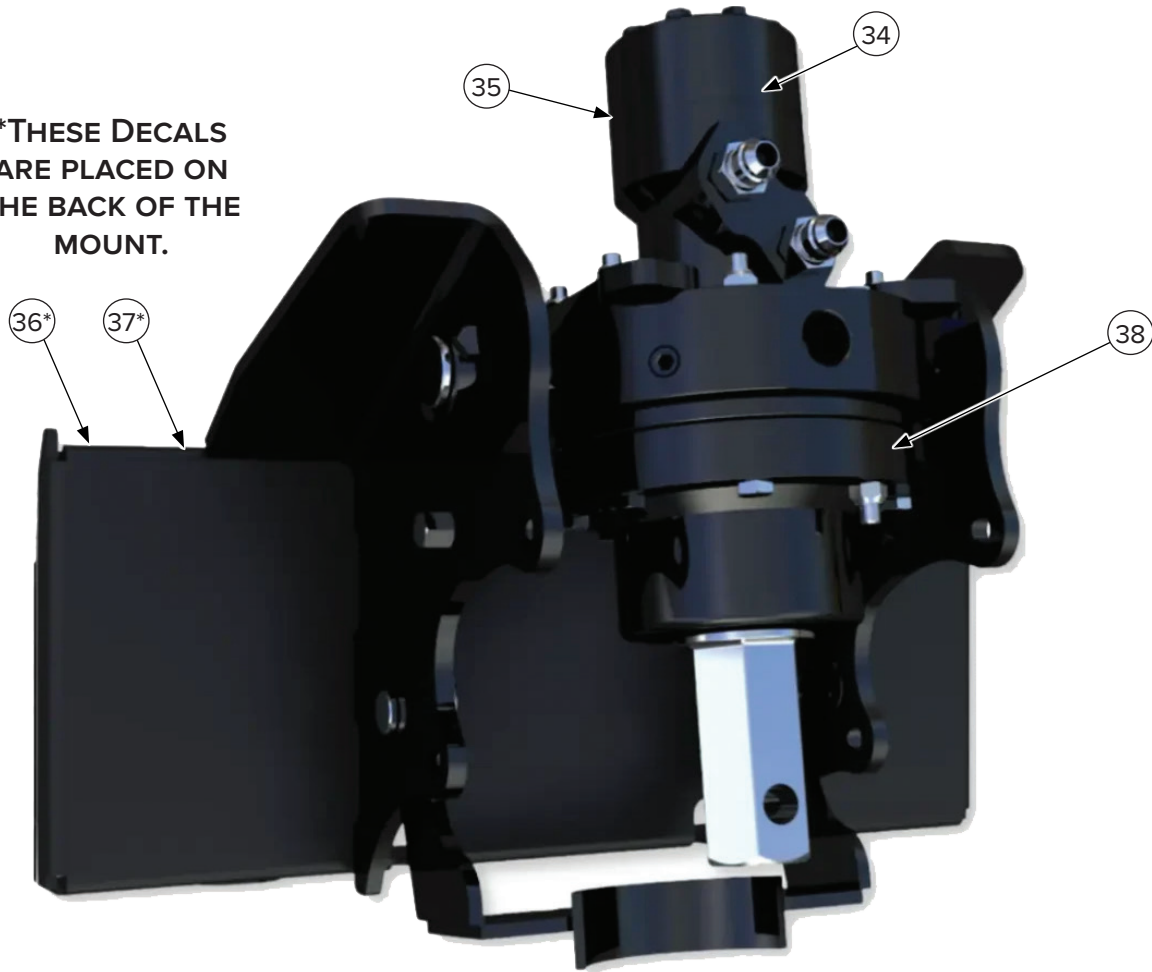

6. Parts

6.4 Safety Decals Cont'd

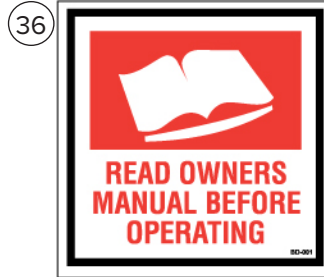

38 **BUILT STRONG. ATTACHED FOR LIFE.**

BD-133

ITEM	PART NUMBER	DESCRIPTION	QTY
34	BD-060	2.4375" x 3.375" Decal, Blue Diamond Attachments	1
35	BD-092	1.5" x 2.0" Decal, Warranty Registration QR	1
36	BD-001	3.0" x 3.0" Decal, Read Owner's Manual	1
37	BD-123	3.0" x 3.0" Decal, High Pressure Fluid Hazard	1
38	BD-133	Decal, Tagline Single Line 1" Tall	1

7. Auger Bits

7.1 Teeth

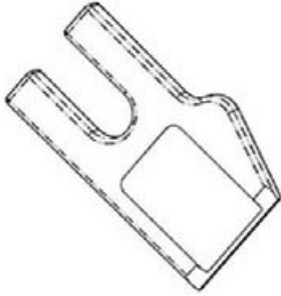

GAUGE TOOTH

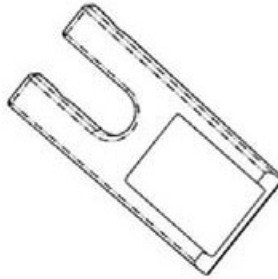

WISDOM TOOTH

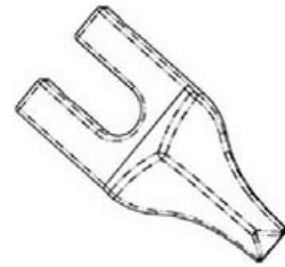

CHISEL TOOTH

DESCRIPTION	GAUGE TOOTH PART NUMBER	WISDOM TOOTH PART NUMBER	CHISEL TOOTH PART NUMBER
Dirt	205010	205015	205505
Hardfaced	205040	205045	205035
Carbide	—	205055	205050

PART NUMBER	DESCRIPTION
205025	5/8" X 1 1/2" Tooth Retaining Bolt
109177	5/8"—11 Stover Lock Nut
205068	Tooth Rubber*

***NOTE:** Use 205068 Tooth Rubber when the teeth are not bolted on to the bit. To properly fit the tooth to the bit, use one (1) pieces of tooth rubber for every tooth.

NOTE: Dirt teeth are the standard factory all bits (Heavy Duty, Heavy Duty with Cast Head, & Tree Bits) except for Rock Bits.

7. Auger Bits

7.2 Pilot/Fishtail

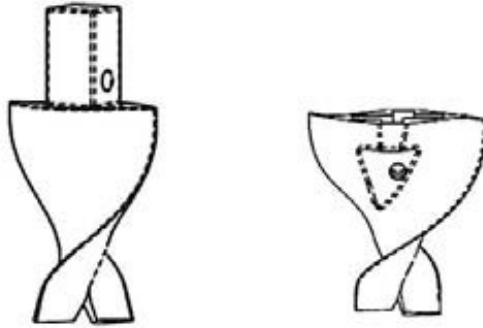

DESCRIPTION	4" DIAMETER FISHTAIL PART NUMBER	FISHTAIL KIT
Dirt	205019	205019-KIT
Hardfaced	205046	—
Carbide	205064	205064-KIT
Retaining Bolt	205023	Included in Kit
Retaining Nut	205021	Included in Kit

DESCRIPTION	6" & LARGER DIAMETER FISHTAIL PART NUMBER	FISHTAIL KIT
Dirt	205020	205020-KIT
Hardfaced	205047	205047-KIT
Carbide	205065	205065-KIT
Retaining Bolt	205022	Included in Kit
Retaining Nut	205021	Included in Kit

NOTE: Dirt teeth are the standard factory all bits (Heavy Duty, Heavy Duty with Cast Head, & Tree Bits) except for Rock Bits.

7. Auger Bits

7.3 Heavy Duty Bits – 4' Length

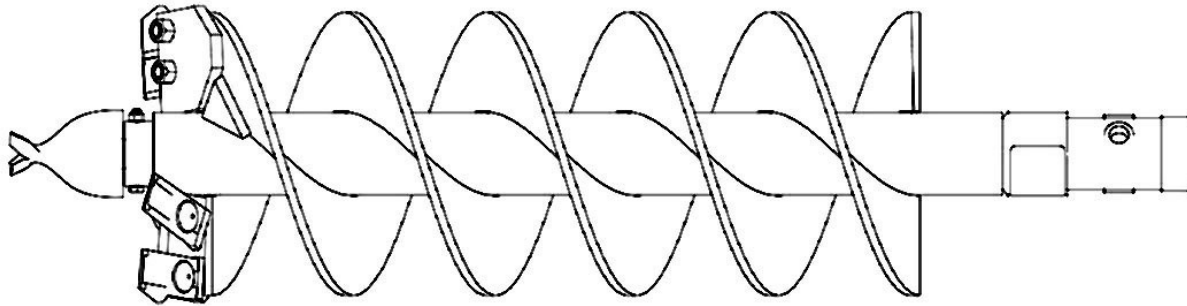

PART NUMBER	DESCRIPTION	QTY
HARDWARE FOR ALL BITS		
205206	3/4"–10 x 4 1/2" Bit Retaining Bolt	1
205210	3/4" Bit Retaining Nut	1
205025	5/8" X 1 1/2" Tooth Retaining Bolt	A/R
109177	5/8"–11 Stover Lock Nut	A/R

AUGER DIAMETER	NO. OF TEETH	2" HEX AUGER PART NUMBER	2 9/16" ROUND AUGER PART NUMBER	TOOTH KIT dirt/hard face/carbide
4"	0	105105	105107	—
6"	2	105110	105111	205015-KIT-DF2
				205045-KIT-HF2
				205055-KIT-CF2
8"	2	105115	105117	205015-KIT-DF2
				205045-KIT-HF2
				205055-KIT-CF2
9"	3	105120	105122	205015-KIT-DF3
				205045-KIT-HF3
				205055-KIT-CF3
10"	3	105125	105127	205015-KIT-DF3
				205045-KIT-HF3
				205055-KIT-CF3
12"	4	105130	105132	205015-KIT-DF4
				205045-KIT-HF4
				205055-KIT-CF4
15"	5	105135	105137	205015-KIT-DF5
				205045-KIT-HF5
				205055-KIT-CF5
18"	6	105145	105146	205015-KIT-DF6
				205045-KIT-HF6
				205055-KIT-CF6

7. Auger Bits

7.3 Heavy Duty Bits – 4' Length Cont'd

AUGER DIAMETER	NO. OF TEETH	2" HEX AUGER PART NUMBER	2 9/16" ROUND AUGER PART NUMBER	TOOTH KIT dirt/hard face/carbide
20"	6	105147	105148	205015-KIT-DF6
				205045-KIT-HF6
				205055-KIT-CF6
24"	8	105150	105152	205015-KIT-DF8
				205045-KIT-HF8
				205055-KIT-CF8

7. Auger Bits

7.4 Heavy Duty with Cast Head Bits – 4' Length

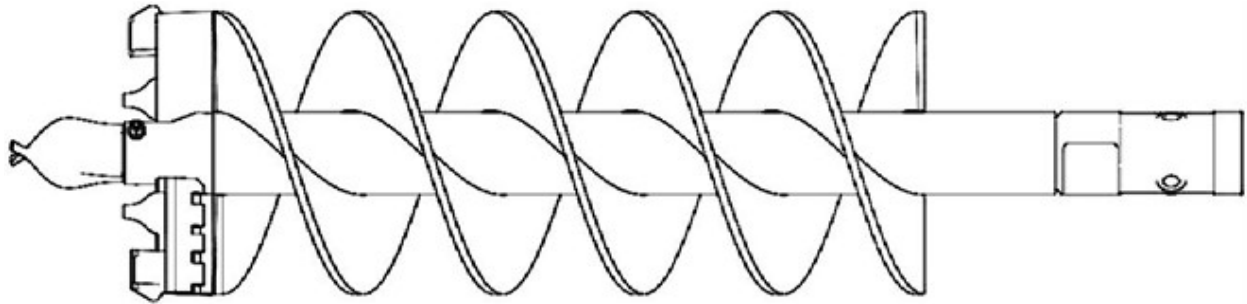

PART NUMBER	DESCRIPTION	QTY
HARDWARE FOR ALL BITS		
205206	3/4"–10 x 4 1/2" Bit Retaining Bolt	1
205210	3/4" Bit Retaining Nut	1
205068	Tooth Rubber	A/R

AUGER DIAMETER	NO. OF TEETH	2" HEX AUGER PART NUMBER	2 9/16" ROUND AUGER PART NUMBER	TOOTH KIT dirt/hard face/carbide
6"	4	105205	105207	205005-KIT-DC4
				205035-KIT-HC4
				205050-KIT-CC4
8"	4	105208	105209	205005-KIT-DC4
				205035-KIT-HC4
				205050-KIT-CC4
9"	4	105215	105212	205005-KIT-DC4
				205035-KIT-HC4
				205050-KIT-CC4
10"	4	105210	105216	205005-KIT-DC4
				205035-KIT-HC4
				205050-KIT-CC4
12"	4	105220	105221	205005-KIT-DC4
				205035-KIT-HC4
				205050-KIT-CC4
15"	6	105225	105226	205005-KIT-DC6
				205035-KIT-HC6
				205050-KIT-CC6
16"	6	105230	105231	205005-KIT-DC6
				205035-KIT-HC6
				205050-KIT-CC6
18"	6	105235	105236	205005-KIT-DC6
				205035-KIT-HC6
				205050-KIT-CC6

7. Auger Bits

7.4 Heavy Duty with Cast Head Bits – 4' Length Cont'd

AUGER DIAMETER	NO. OF TEETH	2" HEX AUGER PART NUMBER	2 9/16" ROUND AUGER PART NUMBER	TOOTH KIT dirt/hard face/carbide
20"	6	105237	105238	205005-KIT-DC6
				205035-KIT-HC6
				205050-KIT-CC6
24"	8	105239	105240	205005-KIT-DC8
				205035-KIT-HC8
				205050-KIT-CC8

7. Auger Bits

7.5 Tree Bits – 4' Length

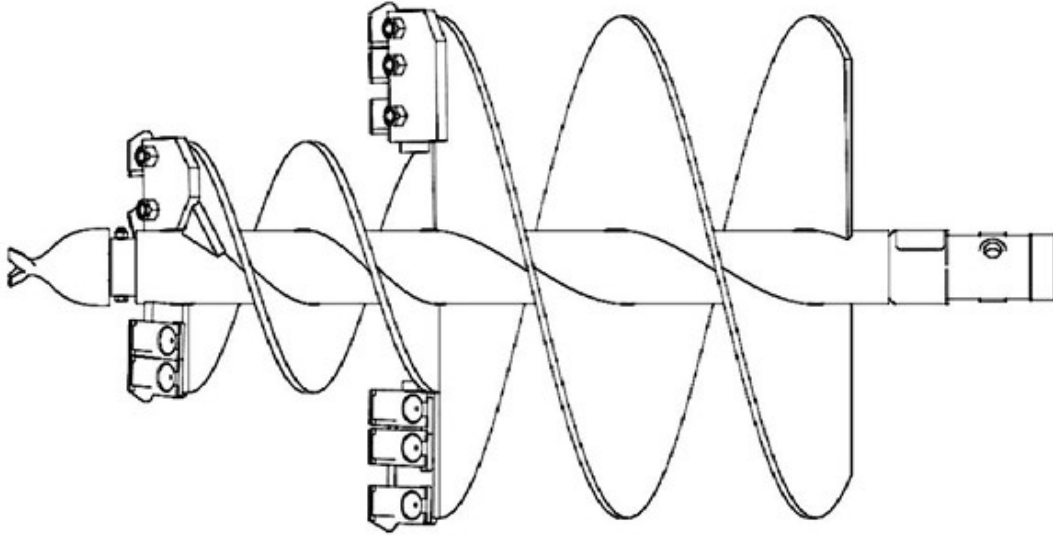

PART NUMBER	DESCRIPTION	QTY
HARDWARE FOR ALL BITS		
205206	3/4"–10 x 4 1/2" Bit Retaining Bolt	1
205210	3/4" Bit Retaining Nut	1
205025	5/8" X 1 1/2" Tooth Retaining Bolt	A/R
109177	5/8"–11 Stover Lock Nut	A/R

AUGER DIAMETER	NO. OF TEETH	2" HEX AUGER PART NUMBER	2 9/16" ROUND AUGER PART NUMBER	TOOTH KIT dirt/hard face/carbide
18" – 9"	7	105405	105407	205015-KIT-DT7
				205045-KIT-HT7
				205045-KITCT7
24" – 12"	10	105410	105412	205015-KIT-DT10
				205045-KIT-HT10
				205045-KITCT10

7. Auger Bits

7.6 Rock Bits – 4' Length

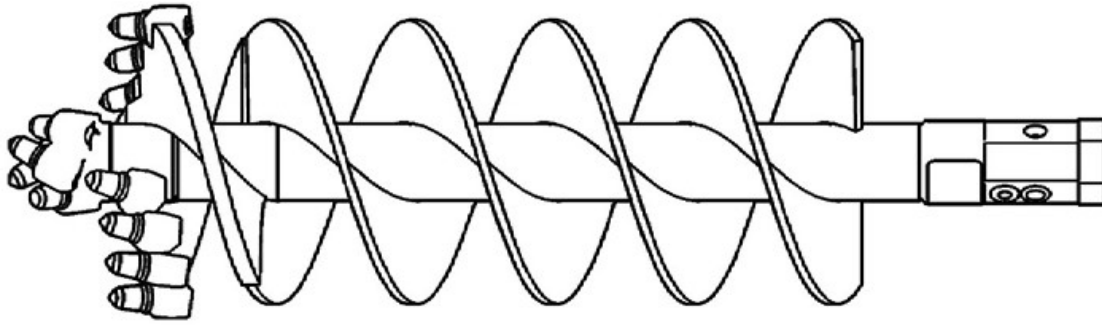

PART NUMBER	DESCRIPTION	QTY
HARDWARE FOR ALL BITS		
205206	3/4"–10 x 4 1/2" Bit Retaining Bolt	1
205210	3/4" Bit Retaining Nut	1

PART NUMBER	DESCRIPTION
FOR BULLET	
205093	Pilot / Center Point with 4 Bullet Teeth Square Shank
205096	Bullet Tooth for Flight
205072	Bullet Tooth Holder

AUGER DIAMETER	NO. OF TEETH	2" HEX AUGER PART NUMBER	2 9/16" ROUND AUGER PART NUMBER	TOOTH KIT dirt/hard face/carbide
4.5"	4	—	105307	—
6"	6	105310	105312	205096-KIT-R6
7"	8	105318	105319	205096-KIT-R8
8"	8	105315	105317	205096-KIT-R8
9"	8	105320	105322	205096-KIT-R8
10"	10	105325	105327	205096-KIT-R10
12"	12	105330	105332	205096-KIT-R12

8. Specifications

8.1 Attachment Specifications

DESCRIPTION	105700	105702
Torque (lbf·ft) @ 3,000 PSI	2,140	
Recommended Flow (GPM)	6 – 16	
Motor Type	Orbital Geroler	
Maximum Pressure (DO NOT EXCEED)	2,900 PSI @ 12 GPM	
Maximum Pressure (DO NOT EXCEED)	15 GPM @ 2280 PSI	
Maximum Horsepower (HP)	20	
Pressure Relief Valve	NO	
Output Shaft	2.0" Hex	
Maximum Drilling Diameter Clay/Shale (in.)	12"	
Maximum Drilling Diameter Earth (in.)	24"	
Weight (lbs)	137	143
Overall Length (in.)	17	18.7
Overall Width (in.)	24.2	
Overall Height (in.)	19	
Diameter (in.)	8	

8. Specifications

8.2 Torque Specifications – Metric

Standard Hardware and Lock Nuts

BOLT TYPE	CLASS 4.8		CLASS 8.8 OR 9.8		CLASS 10.9		CLASS 12.9	
	Lubricated	Dry	Lubricated	Dry	Lubricated	Dry	Lubricated	Dry
M6	4.8 N•m	6 N•m	9 N•m	11 N•m	13 N•m	17 N•m	15 N•m	19 N•m
	3.5 lbf•ft	4.5 lbf•ft	6.5 lbf•ft	8.5 lbf•ft	9.5 lbf•ft	12 lbf•ft	11.5 lbf•ft	14.5 lbf•ft
M8	12 N•m	15 N•m	22 N•m	28 N•m	32 N•m	40 N•m	37 N•m	47 N•m
	8.5 lbf•ft	11 lbf•ft	16 lbf•ft	20 lbf•ft	24 lbf•ft	30 lbf•ft	28 lbf•ft	35 lbf•ft
M10	23 N•m	29 N•m	43 N•m	55 N•m	63 N•m	80 N•m	75 N•m	95 N•m
	17 lbf•ft	21 lbf•ft	32 lbf•ft	40 lbf•ft	47 lbf•ft	60 lbf•ft	55 lbf•ft	70 lbf•ft
M12	40 N•m	50 N•m	75 N•m	95 N•m	110 N•m	140 N•m	130 N•m	165 N•m
	29 lbf•ft	37 lbf•ft	55 lbf•ft	70 lbf•ft	80 lbf•ft	105 lbf•ft	95 lbf•ft	120 lbf•ft
M14	63 N•m	80 N•m	120 N•m	150 N•m	175 N•m	225 N•m	205 N•m	260 N•m
	47 lbf•ft	60 lbf•ft	88 lbf•ft	110 lbf•ft	130 lbf•ft	165 lbf•ft	150 lbf•ft	190 lbf•ft
M16	135 N•m	175 N•m	260 N•m	330 N•m	375 N•m	475 N•m	440 N•m	560 N•m
	100 lbf•ft	125 lbf•ft	195 lbf•ft	250 lbf•ft	275 lbf•ft	350 lbf•ft	325 lbf•ft	410 lbf•ft
M18	135 N•m	175 N•m	260 N•m	330 N•m	375 N•m	475 N•m	440 N•m	560 N•m
	100 lbf•ft	125 lbf•ft	195 lbf•ft	250 lbf•ft	275 lbf•ft	350 lbf•ft	325 lbf•ft	410 lbf•ft
M20	190 N•m	240 N•m	375 N•m	475 N•m	530 N•m	675 N•m	625 N•m	800 N•m
	140 lbf•ft	180 lbf•ft	275 lbf•ft	350 lbf•ft	400 lbf•ft	500 lbf•ft	460 lbf•ft	580 lbf•ft
M22	260 N•m	330 N•m	510 N•m	650 N•m	725 N•m	925 N•m	850 N•m	1075 N•m
	190 lbf•ft	250 lbf•ft	375 lbf•ft	475 lbf•ft	540 lbf•ft	675 lbf•ft	625 lbf•ft	800 lbf•ft
M24	330 N•m	425 N•m	650 N•m	825 N•m	925 N•m	1150 N•m	1075 N•m	1350 N•m
	250 lbf•ft	310 lbf•ft	475 lbf•ft	600 lbf•ft	675 lbf•ft	850 lbf•ft	800 lbf•ft	1000 lbf•ft
M27	490 N•m	625 N•m	950 N•m	1200 N•m	1350 N•m	1700 N•m	1600 N•m	2000 N•m
	360 lbf•ft	450 lbf•ft	700 lbf•ft	875 lbf•ft	1000 lbf•ft	1250 lbf•ft	1150 lbf•ft	1500 lbf•ft
M30	675 N•m	850 N•m	1300 N•m	1650 N•m	1850 N•m	2300 N•m	2150 N•m	2700 N•m
	490 lbf•ft	625 lbf•ft	950 lbf•ft	1200 lbf•ft	1350 lbf•ft	1700 lbf•ft	1600 lbf•ft	2000 lbf•ft
M33	900 N•m	1150 N•m	1750 N•m	2200 N•m	2500 N•m	3150 N•m	2900 N•m	3700 N•m
	675 lbf•ft	850 lbf•ft	1300 lbf•ft	1650 lbf•ft	1850 lbf•ft	2350 lbf•ft	2150 lbf•ft	2750 lbf•ft
M36	1150 N•m	1450 N•m	2250 N•m	2850 N•m	3200 N•m	4050 N•m	3750 N•m	4750 N•m
	850 lbf•ft	1075 lbf•ft	1650 lbf•ft	2100 lbf•ft	2350 lbf•ft	3000 lbf•ft	2750 lbf•ft	3500 lbf•ft

**This page intentionally
left blank**



Warranty

MANUFACTURER'S LIMITED WARRANTY

BLUE DIAMOND® ATTACHMENTS, a manufacturer of quality attachments, warrants new BLUE DIAMOND® ATTACHMENTS products and/or attachments at the time of delivery to the original purchaser, to be free from defects in material and workmanship when properly set up and operated in accordance with the recommendations set forth by BLUE DIAMOND® ATTACHMENTS, LLC.

BLUE DIAMOND® ATTACHMENTS liability for any defect with respect to accepted goods shall be limited to repairing the goods at a BLUE DIAMOND® ATTACHMENTS designated location or at an authorized dealer location, or replacing them, as BLUE DIAMOND® ATTACHMENTS shall elect. The above shall be in accordance with BLUE DIAMOND® ATTACHMENTS warranty adjustment policies. BLUE DIAMOND® ATTACHMENTS obligation shall terminate twelve (12) months for the Mini Auger Drive after the delivery of the goods to original purchaser.

- Twelve (12) months for parts and labor
- Thirty-six (36) months for motor
- Forty-eight (48) months for planetary drive
- Sixty (60) months for gearbox
- Lifetime for output shaft pullout

This warranty shall not apply to any machine or attachment which shall have been repaired or altered outside the BLUE DIAMOND® ATTACHMENTS factory or authorized BLUE DIAMOND® ATTACHMENTS dealership or in any way so as in BLUE DIAMOND® ATTACHMENTS judgment, to affect its stability or reliability, nor which has been subject to misuse, negligence or accident beyond the company recommended machine rated capacity.

WARRANTY CLAIM

To submit a warranty claim, a claim must be filed with BLUE DIAMOND® ATTACHMENTS before work is performed. The BLUE DIAMOND® PRODUCT SUPPORT TEAM will advise repairs and applicable parts exchanges. Tampering with the failed part may void the warranty. This warranty does not include freight or delivery charges incurred when returning machinery for servicing. Dealer mileage, service calls, and pickup/delivery charges are the customers' responsibility.

EXCLUSIONS OF WARRANTY

Except as otherwise expressly stated herein, BLUE DIAMOND® ATTACHMENTS makes no representation or warranty of any kind, expressed or implied, AND MAKES NO WARRANTY OF MERCHANTABILITY IN RESPECT TO ITS MACHINERY AND/OR ATTACHMENTS ARE FIT FOR ANY PARTICULAR PURPOSE. BLUE DIAMOND® ATTACHMENTS shall not be liable for incidental or consequential damages for any breach or warranty, including but not limited to inconvenience, rental of replacement equipment, loss of profits or other commercial loss. Upon purchase, the buyer assumes all liability for all personal injury and property resulting from the handling, possession, or use of the goods by the buyer.

No agent, employee, or representative of BLUE DIAMOND® ATTACHMENTS has any authority to bind BLUE DIAMOND® ATTACHMENTS to any affirmation, representation, or warranty concerning its machinery and/or attachments except as specifically set forth herein.

This warranty policy supersedes any previous documents. Please see bluediamondattachments.com/warranty-policies for the most up to date warranty information.

NOTE: Blue Diamond® Attachments is a trademark of BLUE DIAMOND® ATTACHMENTS



QUALITY | DEPENDABILITY | INTEGRITY

Blue Diamond® Attachments
4512 Anderson Road, Knoxville, TN 37918
888-376-7027