

# Mini Grapple Forks

Operation and Maintenance Manual



106001, 306000, 306005

Register your  
**WARRANTY**  
within 30 days  
of purchase



888-376-7027 | [BlueDiamondAttachments.com](http://BlueDiamondAttachments.com)



# Introduction: Owner Information

Thank you for your decision to purchase a Blue Diamond® Mini Grapple Fork. To ensure maximum performance of your equipment, it is mandatory that you thoroughly study the Operator's Manual and follow the recommendations. Proper operation and maintenance are essential to maximize equipment life and prevent personal injury.

Operate and maintain this equipment in a safe manner and in accordance with all applicable local, state, and federal codes, regulations and / or laws. Follow all on-product labeling and instructions.

Make sure that all personnel have read this Operator's Manual and thoroughly understand safe and correct operating, installation and maintenance procedures.

Blue Diamond® is continually working to improve its products. Blue Diamond® reserves the right to make any improvements or changes as deemed practical and possible without incurring any responsibility or obligation to make any changes or additions to equipment sold previously.

Although great care has been taken to ensure the accuracy of this publication, Blue Diamond® makes no warranty or guarantee of any kind, written or expressed, implied or otherwise with regard to the information contained within this manual. Blue Diamond® assumes no responsibility for any errors that may appear in this manual and shall not be liable under any circumstances for incidental, consequential or punitive damages in connection with, or arising from the use of this manual.

Keep this manual available for frequent reference. All new operators or owners must review the manual before using the equipment and annually thereafter. Contact your Blue Diamond® Attachments Dealer for assistance, information, or additional copies of the manual. Contact [www.bluediamondattachments.com](http://www.bluediamondattachments.com) or call 888-376-7027 for a complete list of dealers in your area.

## Serial Number Location:

Please record attachment information in the space provided for future reference.



Model Number: \_\_\_\_\_

Serial Number: \_\_\_\_\_

Dealer Name: \_\_\_\_\_

Dealer Number: \_\_\_\_\_

Date of Purchase: \_\_\_\_\_

The serial number plate is located on the top right side of the frame as shown above.

Always use your serial number when requesting information or when ordering parts.

**NOTE:** The directions left, right, front, and rear, as mentioned throughout this manual, are as viewed from the operator's position.

# Table of Contents

---

Introduction: <b>Owner Information</b> .....	2
1. Pre-Delivery Inspection Instructions .....	4
1.1 <b>Safety &amp; Documentation</b> .....	4
1.2 <b>Visual Inspection</b> .....	4
1.3 <b>Hydraulic System &amp; Operational Test</b> .....	4
1.4 <b>Final Delivery</b> .....	4
2. Introduction.....	5
2.1 <b>Attachment Identification</b> .....	5
2.2 <b>About this Attachment</b> .....	5
2.3 <b>Attachment Model Numbers</b> .....	5
3. Safety .....	6
3.1 <b>General Safety Information</b> .....	6
3.2 <b>Operators</b> .....	7
3.3 <b>Safety Guidelines</b> .....	8
4. Operation .....	10
4.1 <b>Pre-Operation Inspection</b> .....	10
4.2 <b>Entering &amp; Exiting the Prime Mover</b> .....	11
4.3 <b>Attachment Installation</b> .....	11
4.4 <b>Operating the Attachment</b> .....	13
4.5 <b>Operating Tips</b> .....	14
5. Maintenance .....	16
5.1 <b>Service Schedule</b> .....	16
5.2 <b>Before Each Use</b> .....	17
5.3 <b>After Every Season</b> .....	18
5.4 <b>Lubrication Points</b> .....	18
5.5 <b>Spare Parts &amp; Accessories</b> .....	18
5.6 <b>Storage</b> .....	19
5.7 <b>Troubleshooting</b> .....	19
6. Parts.....	20
6.1 <b>Components</b> .....	20
6.2 <b>Safety Decals</b> .....	22
7. Specifications .....	24
7.1 <b>Attachment Specifications</b> .....	24
7.2 <b>Torque Specifications – Imperial</b> .....	26
Warranty .....	27

# 1. Pre-Delivery Inspection Instructions

---

**Use this checklist to verify safety, function, and readiness prior to delivery.**

END USER'S NAME: \_\_\_\_\_

DATE: \_\_\_\_\_

ITEM NUMBER & DESCRIPTION: \_\_\_\_\_

SERIAL NO.: \_\_\_\_\_

HOST MACHINE MAKE/MODEL: \_\_\_\_\_

## 1.1 Safety & Documentation

- Operation and Maintenance Manual is included.
- Safety decals are present and legible.
- Model and serial number plate is present and intact.
- Verify required hydraulic flow range for customer's skid steer.

## 1.2 Visual Inspection

- Unit is free of shipping damage, dents, cracked welds, etc.
- Ensure cylinder system is correctly lubricated.
- Fasteners are properly torqued.

## 1.3 Hydraulic System & Operational Test

- Hydraulic hose routing is appropriate for application.
- Fittings are properly tightened; verify no leakage.
- Quick couplers are correct and clean.
- Smooth operation; no hydraulic leaks or opening/closing clamp issues.
- Verify attachment has been connected to the host machine that will be used for operation and tested.
- Verify the host machine's hydraulic flow with a flow meter.

## 1.4 Final Delivery

- Maintenance schedule located in Operation and Maintenance Manual has been reviewed.
- Grease type and intervals were provided.
- Register the attachment for warranty by following the instructions below:
  - Fill out this form and email it to [warranty@bdattachments.com](mailto:warranty@bdattachments.com)

TECHNICIAN: \_\_\_\_\_

CUSTOMER: \_\_\_\_\_

DATE: \_\_\_\_\_

## 2. Introduction

### 2.1 Attachment Identification

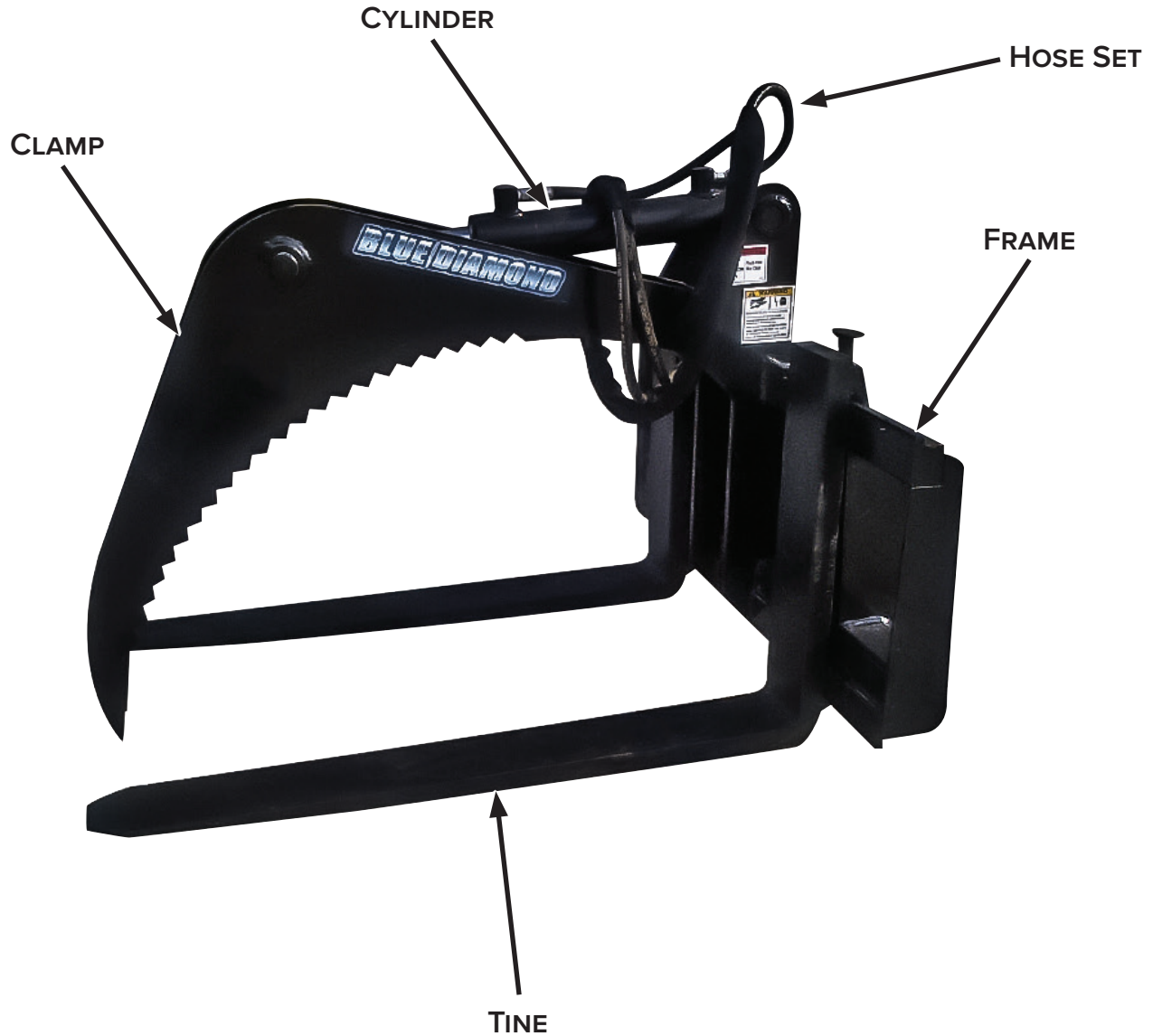

### 2.2 About this Attachment

Blue Diamond® Mini Grapple Forks are a versatile mini skid steer attachment for handling brush, logs, pallets, pipes, and more.

### 2.3 Attachment Model Numbers

MODEL NUMBER	TINES
106001	Sold Separately
306000	1 1/4" x 4" x 36"
306005	1 1/4" x 4" x 42"
306007	1 3/4" x 4" x 42"

**NOTE:** Add -25 for mini universal skid steer mounts, -26 for Bobcat MT mounts, or -35 for Avant mounts.

## 3. Safety

### 3.1 General Safety Information



This **SAFETY ALERT SYMBOL** identifies important safety messages on the equipment and in the owner's manual. When you see this symbol, be alert to the possibility of personal injury and carefully read the message that follows.



The signal word **IMPORTANT** identifies procedures which must be followed to avoid damage to the machine.



The signal word **DANGER** on the machine and in the manuals indicates a hazardous situation which, if not avoided, will result in death or serious injury.



The signal word **WARNING** on the machine and in the manuals indicates a potentially hazardous situation which, if not avoided, could result in death or serious injury.



The signal word **CAUTION** on the machine and in the manuals indicates a potentially hazardous situation which, if not avoided, may result in minor or moderate injury. It may also be used to alert against unsafe practices.

**NOTE:** Notes are used to indicate important information. This information may be repeated in other areas of the manual.

### Terminology

Host Machine, Machine, Prime Mover:

- The Mini Grapple Fork can be attached to many different pieces of equipment; therefore, the terms “host machine”, “machine”, and “prime mover” will be used. Host machine, machine, and prime mover mean any vehicle, tractor, or mini skid steer providing power to the attachment.

Attachment, Implement, Equipment:

- The Mini Grapple Fork is the tool that is being attached to the host machine; therefore, the terms “attachment”, “implement”, and “equipment” will be used. The attachment, implement, and equipment mean any tool that is being used on any vehicle, tractor, or skid steer being used for different applications.

### Operating Safety

- Read and follow instructions in this manual and the machine's Operator's Manual before operating.
- The manual must always remain with the attachment. In case of loss or damage, request a new copy from your dealer or from Blue Diamond®.
- Strictly follow all rules prescribed by the safety pictograms/decals applied to the attachment. Ensure that all safety pictograms/decals are legible. If pictograms/decals are worn, they must be replaced with new ones obtained from Blue Diamond® and placed in the position indicated by this manual.
- Before using the equipment, make sure that all safety devices are installed and in good working condition. In case of damaged or missing shields, replace them immediately.
- It is absolutely forbidden to remove or alter safety devices and/or safety precautions
- Pay maximum attention to avoid any accidental contact with moving parts of the attachment.
- If the use of the equipment is required at night or in conditions of reduced visibility, use the lighting system of the prime mover and an auxiliary lighting system if required.

## 3. Safety

### 3.2 Operators

#### Qualified Operators

The operator is a person suited to the work and who is physically and psychologically able to withstand the demands connected with operating the equipment for its intended use. The operator must not allow anyone to approach the attachment while it is working and must not allow external personnel to operate the machine or attachment.

The operator is to follow the given instructions in this manual and the machine operator's manual in order to obtain maximum performance, minimal fuel consumption, and maximum safety for himself and for others.

The operator is responsible for scrupulously observing all the instructions given in this manual.



**DANGER**



#### **AVOID SERIOUS INJURY OR DEATH**

Operators must receive instructions before operating the machine. Untrained operators can cause serious injury or death.

For an operator to be qualified, he or she must not use drugs or alcoholic drinks which impair alertness or coordination while working. An operator who is taking prescription drugs must get medical advice to determine if he or she can safely operate a machine and the equipment.

For an operator to be qualified, he or she must have read and understood the instructions of this manual, he or she must make adequate preparation for the proper use of the machine, and he or she must hold a driving license.

In case of doubt regarding the use of the attachment and/or the interpretation of this manual, the operator must contact either their dealer or Blue Diamond®.

#### Operator Training

- Check the rules and regulations at your location. The rules may include an employer's work safety requirements. Regulations may apply to local driving requirements or use of a Slow Moving Vehicle (SMV) emblem. Regulations may identify a hazard such as a utility line.
- It is the skill, care, common sense, and good judgment of the operator that will determine how efficiently and safely the job is performed.
- The new operator must start in an area without bystanders and use all the controls until he or she can operate the attachment and machine safely under all conditions of the work area.

#### Operator Safety

- Any use of the attachment other than the intended use is a non-intended use and is considered to be unauthorized and dangerous. Blue Diamond® is liable for any damage or injury resulting from non-intended use.
- It is the responsibility of the operator to follow all local, state, and federal safety regulations. Improper use of this equipment may result in personal injury, property damage, and/or damage to the equipment.
- Before starting, and during operation of the attachment, make sure there are no people or animals in the operation area.
- During operation, adjustment, maintenance, repairing, or transportation of the equipment, the operator must always use appropriate Personal Protective Equipment (PPE) including but not limited to safety glasses, working gloves, dust mask, safety helmet, and hearing protection.  
**NOTE:** Additional safety equipment may be required depending on the operating environment and worksite conditions.
- Do not operate the attachment or machine while wearing loose fitting clothing that can be entangled or caught in parts of the machine.
- Do not operate the implement when tired, not in good condition, or under the influence of alcohol or drugs.

## 3. Safety

---

### 3.3 Safety Guidelines

#### Operating Safety

- Read and follow instructions in this manual and the machine's Operator's Manual before operating.
- Under no circumstances should young children be allowed to work with this equipment.
- This equipment is dangerous to persons unfamiliar with its operation.
- Check for overhead and/or underground lines before operating equipment.
- In addition to the design and configuration of equipment, hazard control and accident prevention are dependent upon the awareness, concern, prudence, and proper training of personnel involved in the operation, transport, maintenance, and storage of equipment.
- Check that the attachment is securely fastened to the machine.
- Make sure all the machine controls are in the NEUTRAL before starting the machine.
- Operate the equipment only from the operator's position.
- Operate the equipment according to the Operator's Manual.
- When learning to operate the equipment, do it at a slow rate in an area clear of bystanders.
- Do not permit personnel to be in the work area when operating the equipment.
- The equipment must be used ONLY on approved machines.
- Do not modify the equipment in any way. Unauthorized modification may impair the function and/or safety and could affect the life of the equipment.
- Do not make any adjustments or repairs on the equipment while the machine is running.
- Keep shields and guards in place. Replace if damaged.
- DO NOT operate equipment in poor visibility conditions such as fog, darkness, or any conditions that limit clear visibility less than 300 feet (100 m) in front of and to the sides of the equipment.
- DO NOT operate in a work area that has not been inspected for foreign debris and obstacles.
- Remove any foreign objects and clearly mark any objects that cannot be removed.
- Know the capabilities of your equipment and practice its operation to become familiar with the controls, emergency shut down procedures, and the way it handles your host machine.
- Wear safety glasses, gloves, hearing protection, and other protective clothing when required.

#### Machine Requirements and Capabilities

- The Mini Grapple Fork must be connected to a host machine with adequate horsepower and lift capacity to provide satisfactory results.
- The machine must be equipped with an auxiliary circuit that is available on the loader arms and is controlled by a switch, pedal, or handle while in the operator's position.
- Keep bystanders clear of moving parts and the work area. Keep children away.
- Do not exceed maximum horsepower (HP) or maximum pressure (PSI) operating pressure as stated for each model in "7.1 Attachment Specifications" on page 24.
- Use caution on slopes and near banks and ditches to prevent overturn.

## 3. Safety

### 3.3 Safety Guidelines Cont'd

#### Fire Prevention Safety

- Flammable debris (leaves, grass, etc.) must be removed regularly. If flammable debris is allowed to accumulate, it can cause a fire hazard. Clean often to avoid this accumulation.
- All fuels, most lubricants, and some coolant mixtures are flammable. Flammable fluids that are leaking or spilled onto hot surfaces or onto electrical components can cause a fire.

#### Transporting Safety

- Comply with state and local laws governing highway safety and movement of machinery on public roads.
- Check local laws for all highway lighting and marking requirements.
- Always yield to oncoming traffic and move to the side of the road so any following traffic may pass.
- Never allow riders on either machine or equipment.
- If transporting the equipment on a truck or trailer, make sure the equipment is properly secured to the transport vehicle.

#### Hydraulic System

- Check hydraulic tubes, hoses, and fittings for damage and leakage. Never use open flame or bare skin to check for leaks. Hydraulic tubes and hoses must be properly routed and have adequate support and secure clamps. Tighten or replace any parts that show leakage.
- Always clean fluid spills. Do not use gasoline or diesel fuel for cleaning parts. Use commercial nonflammable solvents.

#### Personal Protective Equipment



**Proper Work Clothes:** To help ensure your safety as a designated operator wear proper work clothes including tight fitting clothes, protective gloves, and shoes.



**Hand Protection:** To help ensure your safety as a designated operator wear protective gloves.



**Protective Shoes:** To help ensure your safety as a designated operator wear protective shoes.



**Safety Helmet:** To help ensure your safety as a designated operator wear a safety helmet.



**Safety Helmet and Eye/Ear Protection:** To help ensure your safety as a designated operator wear a safety helmet and eye/ear protection.

## 4. Operation

### 4.1 Pre–Operation Inspection

Before operating the Mini Grapple Fork for the first time and each time thereafter, use the following list as a guideline during equipment inspection.



#### WARNING



##### AVOID SERIOUS INJURY OR DEATH

- Disengage machine’s auxiliary hydraulics, engage the machine’s parking brake, stop the engine, and make sure all moving parts are completely stopped before connecting, disconnecting, adjusting, or cleaning equipment.
  - Always keep shields and guards in place when using the equipment.
  - Disengage machine’s auxiliary hydraulics for road travel.
  - Keep hands, feet, and clothing away from rotating parts.
- 
- Inspect the attachment for shipping damage. If damage does exist, do not operate until the damaged parts have been replaced or repaired.
  - Lubricate the attachment per the schedule outlined in the Maintenance section. See “5.4 Lubrication Points” on page 18.
  - Check the attachment mounting frame for damage or cracks.
  - Check that all shields and guards are in place.
  - Check for loose hardware (i.e. nuts, bolts, screws, etc.), and tighten them if necessary.
  - Check all welds on the attachment for wear and damage each time the attachment is removed from the machine.
  - Make sure the tines are not bent or worn.
  - Check for damaged or missing safety decals. Replace if necessary.
  - Inspect the machine’s mounting frame. (See the machine’s Operator’s Manual for inspecting the mounting frame.) Replace any parts that are damaged, bent, or missing. Keep all fasteners tight. Look for cracked welds.

- Verify that the attachment is properly connected to the machine.



#### WARNING



Leaking fluids under pressure can enter the skin and cause serious injury or death. Immediate medical attention is required.

Wear goggles. Use cardboard to check for leaks.

- Check the condition of all hydraulic components for leaks. Repair as required.
- NOTE:** Do not operate with hydraulic leaks.
- Make sure all pivot pins are well lubricated. Re–grease if required.
  - Use only Blue Diamond® recommended replacement parts. Other parts may be substandard in fit and quality.
  - Ensure any damage or excessively worn parts are replaced.
  - Always wear safety goggles or glasses when inspecting equipment.
  - Inspect the work area, confirm that it is free of any utilities, rocks, fence posts, and mark any objects that cannot be removed.
  - Determine a safe and efficient duty cycle pattern before starting the job.

## 4. Operation

### 4.2 Entering & Exiting the Prime Mover



See the machine's Operator's Manual for detailed information on operating the loader.

#### Entering the Operator's Position

Use the safety treads, handles, and steps on the attachment and machine to enter the operator's position. Always maintain three (3) points of contact.

When in the operator's position, face forward and grip the handles. Place both feet on the rear operator platform to engage the operator presence system, start the engine, and release the parking brake.

#### Leaving the Operator's Position



#### AVOID SERIOUS INJURY OR DEATH

- Always park on a flat, level surface.
- Lower lift arms and place attachment flat on the ground.
- Place all controls in NEUTRAL.
- Engage the parking brake.
- Stop the engine, and remove the key.
- Wait for all moving parts to stop.

**SEE MACHINE'S OPERATOR'S MANUAL FOR ADDITIONAL INFORMATION.**

Park the machine/attachment on a flat, level surface.

Place all controls in neutral, engage the parking brake, stop the engine, and wait for all moving parts to stop. Leave the operator's position.

### 4.3 Attachment Installation

#### Connecting Attachment to the Machine



**CRUSH HAZARD**

- Before moving the machine, look in all directions and make sure no bystanders, especially small children are in the work area. Do not allow anyone between the machine and attachment when approaching the attachment for connecting.
- Keep fingers and hands out of pinch points when connecting and disconnecting the attachment.

Before connecting to the attachment, inspect the machine's mounting plate. (See the machine's Operator's Manual for inspecting the mounting frame.)

Enter the operator's position. See "Entering the Operator's Position" on page 11.

Drive the machine slowly forward until the top edge of the machine's mounting plate is under the top flange of the attachment mounting frame.

Slowly tilt the machine's mounting plate back until the attachment mounting frame fully contacts the front of the machine's mounting plate.

Leave the operator's position. See "Leaving the Operator's Position" on page 11.

## 4. Operation

### 4.3 Attachment Installation Cont'd

#### Connecting Attachment to the Machine Cont'd



### WARNING



#### AVOID SERIOUS INJURY OR DEATH

The locking pins/wedges must extend through the holes in the attachment mounting frame. Failure to secure locking pins/wedges can allow attachment to come off.

**SEE MACHINE'S OPERATOR'S MANUAL FOR  
ADDITIONAL INFORMATION.**

Engage attachment locking levers/wedges. (See the machine's Operator's Manual for detailed information.)

#### Connecting Hydraulic Hoses



### IMPORTANT



Thoroughly clean the quick couplers before making connections. Dirt can quickly damage the hydraulic system.

Verify that all hydraulic couplings are compatible with the host machine.

Remove dirt or debris from the male and female couplers. Visually inspect the couplers for corroding, cracking, damage, or excessive wear. Replace as needed.

Connect the attachment hydraulic hoses to the machine. The hydraulic hoses must be connected in the following order: return hose then pressure hose.

For the hydraulic hoses, the return hose must be connected before the pressure hose.

Pull on each hose to verify full connection is made.

#### Disconnecting Hydraulic Hoses



### WARNING



#### AVOID SERIOUS INJURY OR DEATH

Hydraulic fluid, tubes, fittings, and quick couplers can get hot during operation. Be careful when connecting and disconnecting hydraulic hoses.

Relieve auxiliary hydraulic pressure. (See the machine's Operator's Manual for correct procedure.)

Disconnect attachment hydraulic hoses from the machine. The hoses must be disconnected in the following order: pressure hose then return hose.

The pressure hose must be disconnected before the return hose.

#### Disconnecting Attachment From the Machine

Relieve auxiliary hydraulic pressure. (See the machine's Operator's Manual for correct procedure.)

Park the machine and attachment on a flat, level surface. Lower the attachment flat on the ground.

Leave the operator's position. See "Leaving the Operator's Position" on page 11.

Disconnect attachment hydraulic hoses from the machine.

Disengage locking pins/wedges. (See the machine's Operator's Manual for correct procedure.)

Enter the operator's position. See "Entering the Operator's Position" on page 11.

Slowly tilt the machine's mounting plate forward until the attachment mounting frame is free from the machine's mounting plate.

Drive the machine slowly backward, away from the attachment.

## 4. Operation

### 4.4 Operating the Attachment

#### Machine Requirements



#### WARNING



##### AVOID SERIOUS INJURY OR DEATH

Never allow riders on the attachment.

Only use the attachment on compatible host machines.

Refer to the machine's Operator's Manual for flow and pressure specifications.

Refer to the machine's Operator's Manual for instructions on how to open and close the clamp as well as height and tilt functions of the machine's arms.

#### Engaging the Attachment for the First Time



#### IMPORTANT



If this is the initial setup with this attachment on this machine, check the host machine's hydraulic oil level and add oil, if necessary, before and after doing steps 1 – 2 below.

After starting the machine, lift the attachment 10" (254 mm) off the ground surface:

1. With the machine's engine RPMs just above idle, slowly engage the auxiliary hydraulics to open the clamp. With the machine's RPMs just above idle, slowly engage the auxiliary hydraulics to open the clamp. Move the auxiliary control pedal, lever, or switch in the opposite direction to close the clamp. Repeat this three (3) times to purge any air from the system.
2. Lower the attachment to the ground and shut off the host machine's engine. Leave the operator's position. See "Leaving the Operator's Position" on page 11.
3. Check the machine's hydraulic oil level, and add oil if necessary.

4. Inspect the attachment's hydraulic system for any noticeable leaks. If leaks are present, correct before continuing operation.

#### Getting Familiar with the Attachment



#### DANGER



##### AVOID SERIOUS INJURY OR DEATH

Never operate the grapple arms when bystanders are within 10 ft (3 m) of the work area.



#### CAUTION



##### AVOID INJURY

Be cautious when operating on uneven ground surfaces. A machine rollover could result in minor or serious injury. Always wear your seatbelt when operating this type of machinery.

Before starting the engine with the grapple attachment connected to the host machine, make sure you are familiar and comfortable with the operation of the auxiliary hydraulic controls as outlined in the previous sections of this manual and in the machine's Operator's Manual.

When operating the grapple attachment, set the host machine's throttle at a speed that will produce the required flow to the attachment and other machine functions. If the machine is equipped with a foot throttle, use it to control the engine speed and power being delivered to the attachment. Refer to the machine's Operator's Manual or call your local dealer for additional help if necessary.

At the start, learn what the attachment looks like in a level position when in the operator's position.

The correct ground speed for this attachment depends on the application and conditions, which can be monitored by sound and feel depending on the material density. If the machine's engine is bogging down because of a heavy load, raise or decrease the load a little at a time until the machine's power can overcome the material load on the attachment.

## 4. Operation

### 4.4 Operating the Attachment Cont'd

#### Operating the Grapple Fork



### WARNING



#### AVOID SERIOUS INJURY OR DEATH

Use extreme caution when moving debris to keep them hitting yourself or bystanders.

1. Install the attachment onto the host machine. (See “4.3 Attachment Installation” on page 11.)
2. Enter the operator’s position. (See “Entering the Operator’s Position” on page 11.)
3. Raise the attachment slightly off the ground.
4. Cycle the Mini Grapple Fork’s cylinder several times to purge the hydraulic system of air. (See the machine’s Operator’s Manual for precise instructions in regards to these functions.)
5. To pick up debris, fully open the clamp and drive forward. The debris should collect against the back of the attachment.
6. Cycle the cylinder to close the clamp.
7. Use the machine to adjust the height of the attachment. The machine’s tilt cylinders can be used to level the attachment.
8. When done handling debris, close the clamp to prevent serious injury or death.

### 4.5 Operating Tips



### CAUTION



#### AVOID INJURY

Be cautious when operating on uneven ground surfaces. A machine rollover could result in minor or serious injury. Always wear your seatbelt when operating this type of machinery.

- Always inspect the work area before starting the job. Locate and mark any utilities, steel posts, rocks, or any objects that could be damaged or cause damage to the attachment during operation. Never assume the work area is safe. Never skip “4.1 Pre-Operation Inspection” on page 10.
- Operate at a safe, slow speed that will allow proper vigilance for the area ahead and behind the machine and attachment. Look behind the attachment/machine when in reverse. Verify that the machine’s backup alarm is in proper working condition to warn others when in reverse in addition to proper vigilance.
- Overloading the attachment will result in spinning the tracks or tires and will make unwanted ruts. If a load is lifted that is too heavy with the Mini Grapple Fork, it will raise the rear of the host machine and reduce the tractive power available to move the load.
- Center the load on the attachment. Estimate the center, and lift the attachment accordingly. If the load feels unbalanced when lifted, stop the host machine, lower the load, and reposition. Try lifting again afterwards. An unbalanced load can overturn the host machine.
- After loading the attachment and closing the clamp onto the load, roll the attachment back and re-tighten the clamp’s pressure. When rolling back the attachment, the load will settle and require some additional clamp pressure to secure the load.

## 4. Operation

### 4.5 Operating Tips Cont'd



#### WARNING



##### AVOID SERIOUS INJURY OR DEATH

When lifting a load of brush or trees, make sure all ends are not tangled with standing trees that could cause the center of gravity to be compromised, resulting in a rollover that could cause serious injury or death.

- The attachment's clamp should not be used for pushing or pulling down trees or any type of structure. The clamp's purpose is to clamp the load so it can be moved to a different spot on the job site.
- To avoid service work and downtime, always pay attention so that tree branches or roots do not extend through past the attachment's frame and damage any hydraulic parts or enter the cab area.
- Be careful that a branch or root does not "whip" back at the host machine. Wear safety glasses to protect your eyes from dirt and debris.



#### WARNING



##### AVOID SERIOUS INJURY OR DEATH

Use extreme caution when working around low hanging electrical lines. Do not raise the attachment in an area where there are low electrical lines to prevent an accident that could result in serious injury or death.

- Maintain distance from any type of utility, whether underground or overground.
- Always clean the quick couplers before connecting them to the host machine. Use plastic or metal caps to protect the ends or connect them to each other when not in use. Tuck the hoses somewhere in the attachment where they will be kept clean and not driven over.
- When traveling around the work site, be sure to lift the attachment high enough off the ground so that the clamp is not dragging across the ground. This can cause extensive damage to the clamp and the hydraulic system.

## 5. Maintenance

### 5.1 Service Schedule

DESCRIPTION	SERVICE PROCEDURES					
	Check	Clean	Lube	Change	Adjust	Drain
Daily Maintenance (or every 8 hours)						
Hydraulic Fittings	•					
Hydraulic Hoses	•					
Frame (cracks, bends, or excessive damage)	•	•				
Hydraulic Cylinder	•					
Shields & Guards	•					
Attachment Welds	•					
Safety Decals	•					
Tines (wear or bends)	•					
Pivot Points		•	•			
All Hardware	•					

## 5. Maintenance

Proper and regular maintenance ensures a long life of the attachment, avoids failures, and saves time and repair costs.

Periodic inspections and maintenance operations described in this section must be performed by an operator in times and terms prescribed. Failure to comply with maintenance prescriptions can compromise the function and lifetime of the attachment, which will result in the warranty becoming void.

Repairs, maintenance, and modifications other than those mentioned in this manual should NOT be performed without consulting Blue Diamond® Product Support.

Wrong or inappropriate repairs or maintenance may generate abnormal operating conditions, equipment damage, and generate risks for the operator.



### WARNING



#### AVOID SERIOUS INJURY OR DEATH

The following must always be performed prior to any adjustment being made:

- Always park on a flat, level surface.
- Lower lift arms, and place attachment flat on the ground.
- Place all controls in NEUTRAL.
- Engage the parking brake.
- Stop the engine, and remove the key.
- Wait for all moving parts to stop.
- Set the parking stand.

**SEE MACHINE'S OPERATOR'S MANUAL FOR ADDITIONAL INFORMATION.**

## 5.2 Before Each Use

Before each use, perform the following:

- Walk around the equipment while following the guidelines laid out in “4.1 Pre–Operation Inspection” on page 10.
- Perform a daily inspection as indicated in “5.1 Service Schedule” on page 16.
- Verify that the proper attachment is being used for the task at hand. Use the Mini Grapple Fork for material handling only.
- Verify that the attachment is being used on an appropriate host machine.



### IMPORTANT



Using an incompatible host machine could result in damage to the attachment or host machine.

**NOTE:** If the attachment has been in storage or has not been used for an extended period of time, wipe down the chrome portion of the cylinder with hydraulic fluid to prevent snagging the seals.



### DANGER



#### AVOID SERIOUS INJURY OR DEATH

Keep all body parts from the clamp and tines when in use. The clamp may open or close unexpectedly, causing serious injury or death.

Inspect the attachment daily before each use. It is also recommended to inspect the Mini Grapple Fork after extreme use or damage. Use the “5.1 Service Schedule” on page 16 as a guideline.

## 5. Maintenance

### 5.3 After Every Season

Inspect the attachment for any loose or worn parts that may need replaced prior to the next season.

Clean and repaint any area that looks worn or scratched to prevent further rusting. Use an equipment paint found at your local hardware store or building center

Replace any safety decals that have been lost or damaged.

Store the attachment in a shed or cover with a waterproof tarp to protect it from weather. Store in an area not frequented by children.

To see more information on storing your attachment, see “5.6 Storage” on page 19.

### 5.4 Lubrication Points

Grease all pivot points every eight (8) hours of use to prevent excess wear on the clamp pins and cylinder pins.

The Mini Grapple Fork has four (3) grease points [Figure 1].

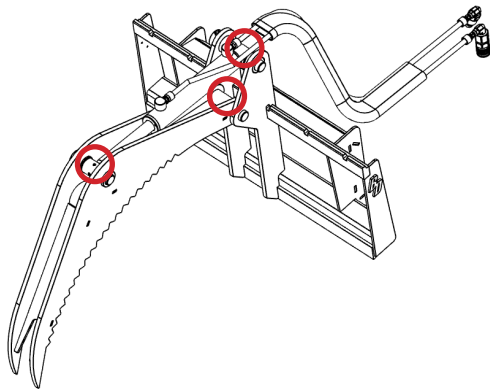

Figure 1

### 5.5 Spare Parts & Accessories

To maintain safety, performance, and product reliability, Blue Diamond® recommends the use of genuine Blue Diamond® replacement parts for all repairs and service.

Genuine Blue Diamond® parts are specifically designed and tested for your attachment. These components include critical items, such as hydraulic motors, cylinders, and structural weldments.

Use of non-genuine parts for components identified as Blue Diamond® OEM may affect product performance and could void applicable warranty coverage.

To obtain replacement parts, contact Blue Diamond® Product Support with the following information:

- Type of attachment
- Serial number
- Part number and/or description of part(s) needed
- Quantity of part(s) needed

## 5. Maintenance

### 5.6 Storage

#### Storage

Sometimes it may be necessary to store your Mini Grapple Fork for an extended period of time. Below is a list of items to perform before storage.

- Make sure the hydraulic hose couplers are capped, plugged, or connected to each other.
- Thoroughly wash the attachment before storing it for long periods.
- Lubricate the attachment.
- Coat the exposed portion of the cylinder with oil.
- Check for loose hardware, missing guards, or damaged parts.
- Check for damaged or missing decals. Replace if necessary.
- Replace worn or damaged parts.
- Place the attachment flat on the ground in a dry, protected shelter.

**NOTE:** In muddy conditions or to prevent the attachment from freezing to the ground, put the attachment on planks or blocks before removing the attachment from the machine.

#### Return to Service

After the Mini Grapple Fork has been in storage, it is necessary to follow a list of items to return the attachment to service.

- Lubricate the attachment.
- Clean the exposed portion of the cylinder rod and apply a light coating of oil.
- Connect and operate the attachment and check for correct function.
- Check for leaks. Repair as needed.

### 5.7 Troubleshooting

PROBLEM	CAUSE	SOLUTION
Hydraulic oil level goes down during operation.	Leak at hoses on the attachment	Investigate and repair.
	Leak in the prime mover hydraulic system	Investigate and repair.
Tines do not open or close.	Quick disconnects not connected	Check and recouple quick disconnects.
	Hoses damaged	Check for a smashed or kinked hose. Replace if found.
	Mini skid steer auxiliary circuit inoperative.	Investigate and repair.
Tines move abnormally slow.	Restricted hose	Check for damaged hose between mini skid steer and cylinder. If damaged, replace the hose.
	Bad circuit relief on mini skid steer	Investigate and repair.
	Auxiliary valve spool on mini skid steer not shifting properly	Investigate and repair.
	Cylinder seals bypassing	Have cylinder repacked or replaced.
Cylinder is erratic or slow.	Orifice restriction not proper for application	Investigate and repair.

## 6. Parts

### 6.1 Components

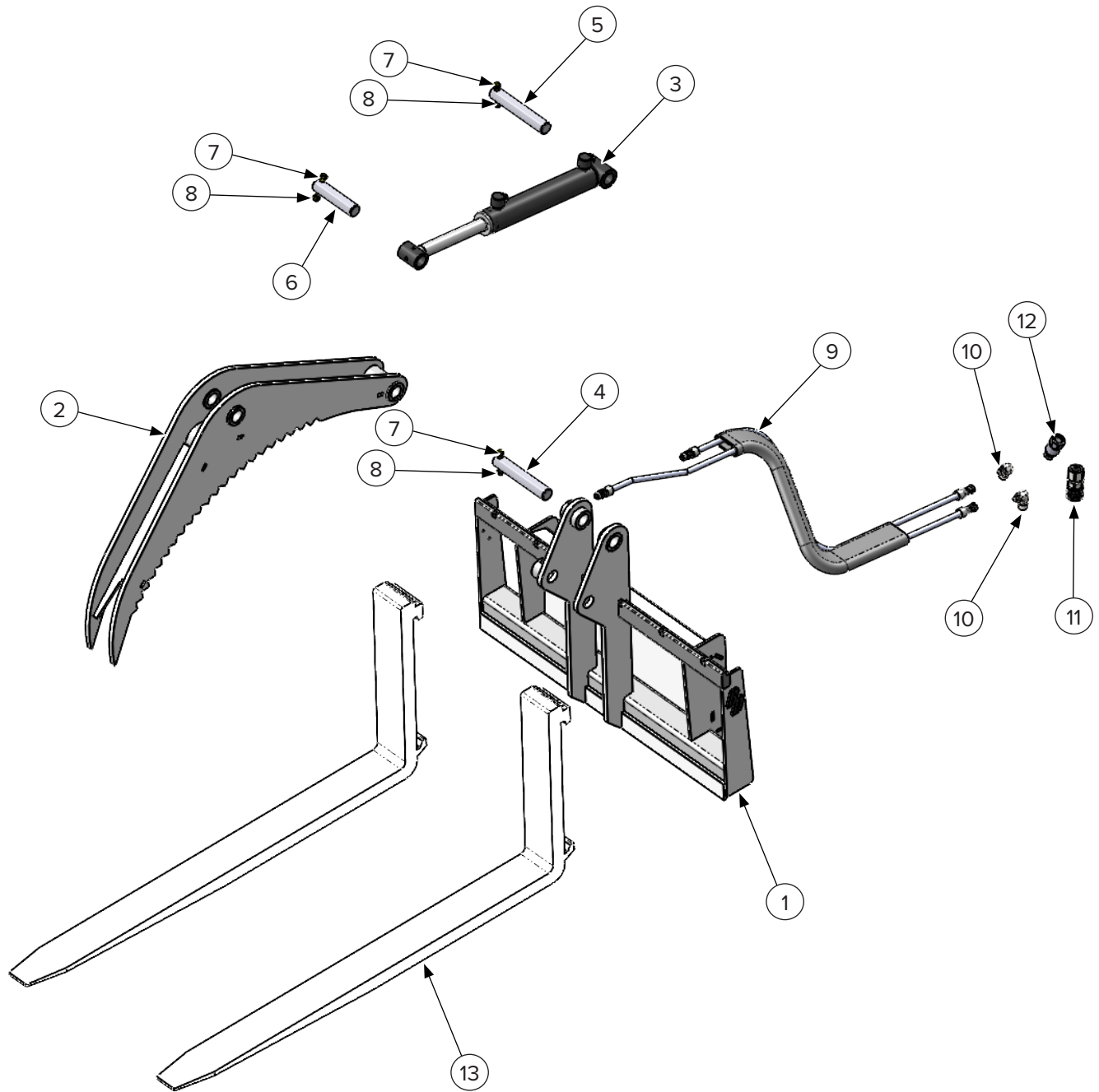

## 6. Parts

### 6.1 Components Cont'd

ITEM	PART NUMBER	DESCRIPTION	REV 000 QTY	REV 001 QTY
1	206004-25	Mini Universal Skid Steer Mount	1	1
1	206004-26	Bobcat MT Mount	1	1
2	206020	Clamp	1	1
3	206305-KIT	Cylinder with Adapters	1	—
3	206306	Cylinder, 2" Bore x 10" Stroke with 3/8" Ports	—	1
4	211116	Pivot Pin, 7 1/4" Long x 1 1/4" Diameter with Bolt Hole	1	1
5	206018	Pivot Pin, 7 1/2" Long x 1 1/4" Diameter with Bolt Hole	1	1
6	206415	Pivot Pin, 5 1/2" Long x 1 1/4" Diameter with Bolt Hole	1	1
7	299329	3/8"—16 x 2 1/2" Hex Head Bolt Grade 8	3	3
8	299625	3/8"—16 Locknut Grade 8	3	3
9	206012	Hose Set	1	—
9	206019	Hose Set, 84" OAL	—	1
10	295030-M06JIC-M08NPT	Hydraulic 90 Degree Fitting Male #6 JIC x Male #8 Pipe Thread	2	2
11	224005	Female Coupler, Flat Face Straight 1/2" Body Female #8 NPT	1	1
12	224006	Male Coupler, Flat Face Straight 1/2" Body Female #8 NPT	1	1
13	114109	1 1/4" x 4" x 36" Standard Pallet Fork Tine Class 2	2	2
13	114115	1 1/4" x 4" x 42" Standard Pallet Fork Tine Class 2	2	2
13	114123	1 3/4" x 4" x 42" Standard Pallet Fork Tine Class 2	2	2

## 6. Parts

### 6.2 Safety Decals

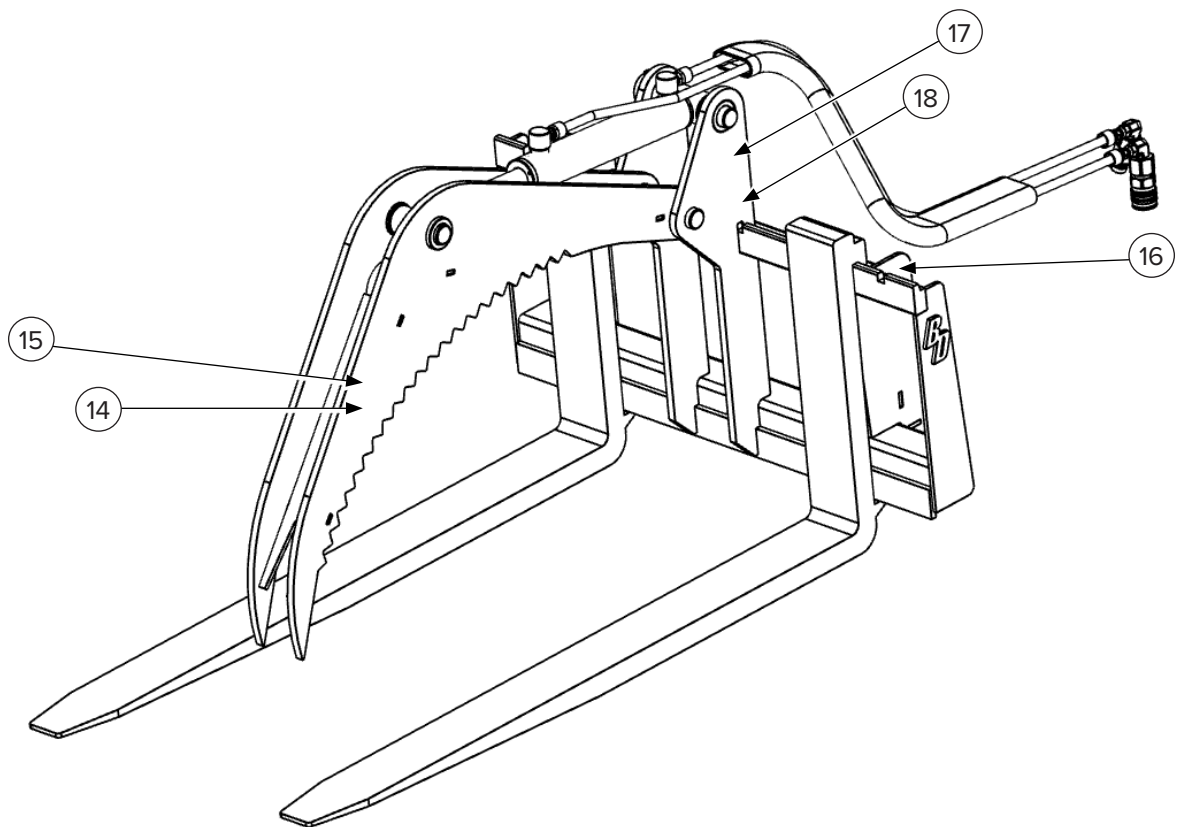
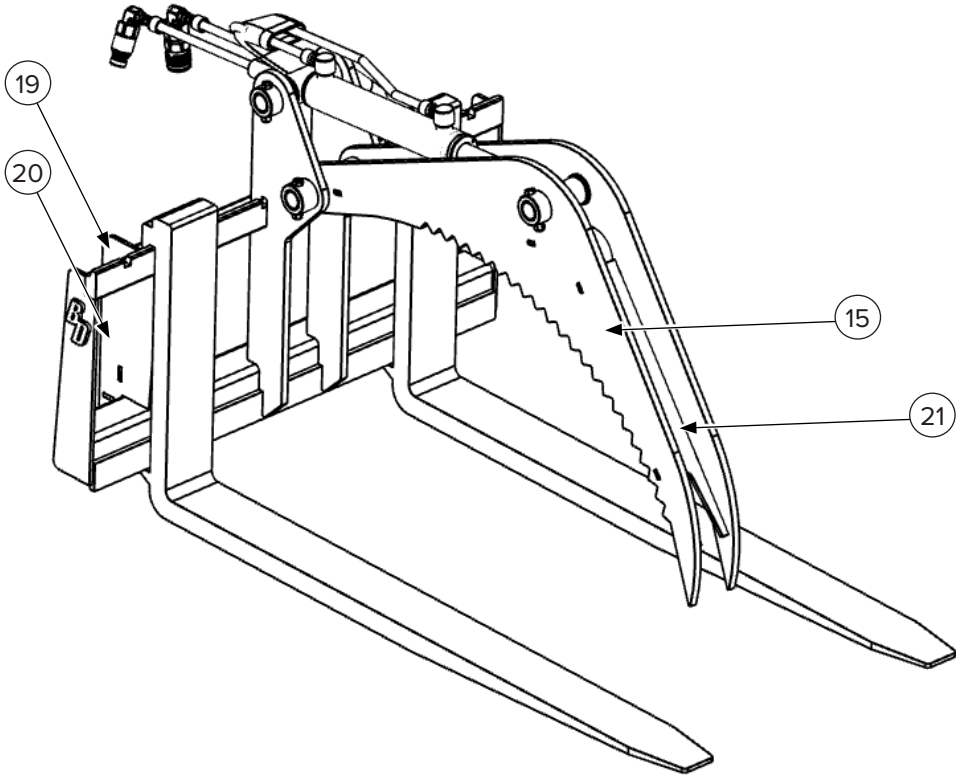

## 6. Parts

### 6.2 Safety Decals Cont'd

14 **BUILT STRONG. ATTACHED FOR LIFE.** BD-133

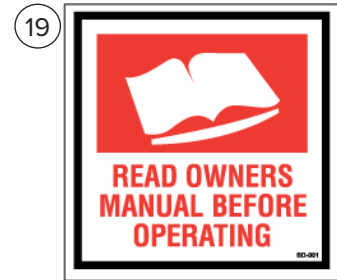
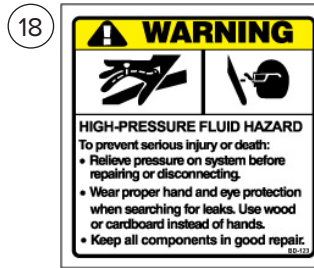

ITEM	PART NUMBER	DESCRIPTION	QTY
14	BD-133	Decal, 1" Tall Single Line Tagline	1
15	BD-056	2.0" x 12.0" Decal, Blue Diamond	2
16	BD-060	2.4375" x 3.375" Decal, Blue Diamond Attachments	1
17	BD-092	1.5" x 2.0" Decal, Warranty Registration QR	1
18	BD-123	3.0" x 3.0" Decal, High Pressure Fluid Hazard	1
19	BD-001	3.0" x 3.0" Decal, Read Owner's Manual	1
20	BD-004	2.0" x 4.0" Decal, Grease All Fitting Every 8 Hours	1
21	BD-003	2.5" x 2.5" Decal, Crush Hazard Stay Clear	1

## 7. Specifications

### 7.1 Attachment Specifications

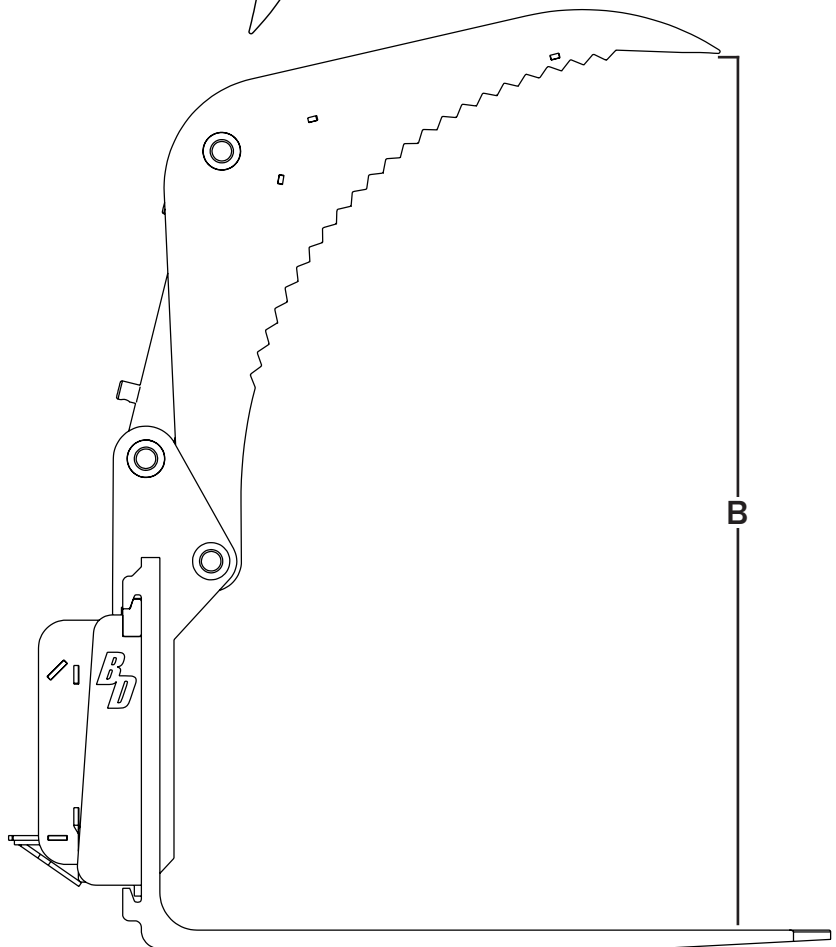
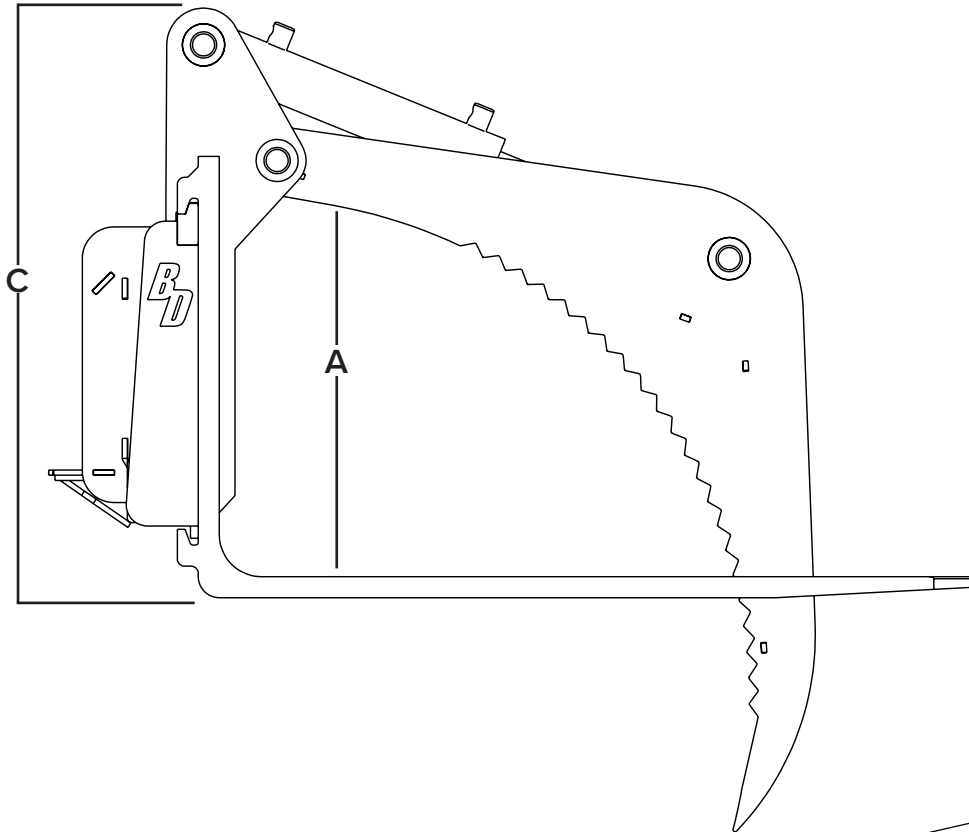

## 7. Specifications

### 7.1 Attachment Specifications Cont'd

DESCRIPTION	106001	306000	306005	306007
Overall Width	35 1/2 in. (901 mm)			
Inside Height with Closed Clamp (A)	17 3/4 in. (450 mm)			
Opening Height (B)	47 in. (1,193 mm)			
Height (C)	28 in. (711 mm)			
Required Hydraulic Flow (GPM)	6 – 16 GPM (22 – 60 LPM)			
Lift Capacity	3,000 lb (1360 kg)			
Maximum Pressure	3,000 PSI (206 bar)			
Fork Tine Class	Class 2			
Rated Horsepower	45 HP			
Weight (without Tines)	255 lb (115 kg)			

## 7. Specifications

### 7.2 Torque Specifications – Imperial Standard Hardware and Lock Nuts

BOLT TYPE	SAE GRADE 5		SAE GRADE 8		LOCK NUTS			
	Plated or Unplated Silver	Plated W/ ZnCr Gold	Plated or Unplated Silver	Plated W/ ZnCr Gold	Plated or Unplated Silver	Plated W/ ZnCr Gold	W/ Grade 5 Bolt	W/ Grade 8 Bolt
1/4	4.6 lbf•ft	6.0 lbf•ft	7.2 lbf•ft	9.3 lbf•ft	10.0 lbf•ft	13.1 lbf•ft	5.1 lbf•ft	7.2 lbf•ft
	6.2 N•m	8.1 N•m	9.7 N•m	12.6 N•m	13.6 N•m	17.7 N•m	6.9 N•m	9.8 N•m
5/16	9.6 lbf•ft	12.5 lbf•ft	14.8 lbf•ft	19.2 lbf•ft	20.7 lbf•ft	27.3 lbf•ft	10.3 lbf•ft	14.8 lbf•ft
	13 N•m	17 N•m	20 N•m	26 N•m	28 N•m	37 N•m	14 N•m	20 N•m
3/8	17 lbf•ft	22 lbf•ft	26 lbf•ft	34 lbf•ft	37 lbf•ft	48 lbf•ft	19 lbf•ft	26 lbf•ft
	23 N•m	30 N•m	35 N•m	46 N•m	50 N•m	65 N•m	26 N•m	35 N•m
7/16	27 lbf•ft	35 lbf•ft	42 lbf•ft	54 lbf•ft	59 lbf•ft	77 lbf•ft	30 lbf•ft	42 lbf•ft
	37 N•m	47 N•m	57 N•m	73 N•m	80 N•m	104 N•m	41 N•m	57 N•m
1/2	42 lbf•ft	54 lbf•ft	64 lbf•ft	83 lbf•ft	91 lbf•ft	117 lbf•ft	45 lbf•ft	65 lbf•ft
	57 N•m	73 N•m	87 N•m	113 N•m	123 N•m	159 N•m	61 N•m	88 N•m
9/16	60 lbf•ft	77 lbf•ft	92 lbf•ft	120 lbf•ft	130 lbf•ft	169 lbf•ft	65 lbf•ft	92 lbf•ft
	81 N•m	104 N•m	125 N•m	163 N•m	176 N•m	229 N•m	88 N•m	125 N•m
5/8	83 lbf•ft	107 lbf•ft	128 lbf•ft	165 lbf•ft	180 lbf•ft	233 lbf•ft	90 lbf•ft	127 lbf•ft
	112 N•m	145 N•m	174 N•m	224 N•m	244 N•m	316 N•m	122 N•m	172 N•m
3/4	146 lbf•ft	189 lbf•ft	226 lbf•ft	293 lbf•ft	319 lbf•ft	413 lbf•ft	160 lbf•ft	226 lbf•ft
	198 N•m	256 N•m	306 N•m	397 N•m	432 N•m	560 N•m	217 N•m	306 N•m
7/8	142 lbf•ft	183 lbf•ft	365 lbf•ft	473 lbf•ft	515 lbf•ft	667 lbf•ft	258 lbf•ft	364 lbf•ft
	193 N•m	248 N•m	495 N•m	641 N•m	698 N•m	904 N•m	350 N•m	494 N•m
1	213 lbf•ft	275 lbf•ft	547 lbf•ft	708 lbf•ft	773 lbf•ft	1000 lbf•ft	386 lbf•ft	545 lbf•ft
	289 N•m	373 N•m	742 N•m	960 N•m	1048 N•m	1356 N•m	523 N•m	739 N•m



## Warranty

### MANUFACTURER'S LIMITED WARRANTY

BLUE DIAMOND® ATTACHMENTS, a manufacturer of quality attachments, warrants new BLUE DIAMOND® ATTACHMENTS products and/or attachments at the time of delivery to the original purchaser, to be free from defects in material and workmanship when properly set up and operated in accordance with the recommendations set forth by BLUE DIAMOND® ATTACHMENTS, LLC.

BLUE DIAMOND® ATTACHMENTS liability for any defect with respect to accepted goods shall be limited to repairing the goods at a BLUE DIAMOND® ATTACHMENTS designated location or at an authorized dealer location, or replacing them, as BLUE DIAMOND® ATTACHMENTS shall elect. The above shall be in accordance with BLUE DIAMOND® ATTACHMENTS warranty adjustment policies. BLUE DIAMOND® ATTACHMENTS obligation shall terminate twelve (12) months for the Mini Grapple Fork after the delivery of the goods to original purchaser.

This warranty shall not apply to any machine or attachment which shall have been repaired or altered outside the BLUE DIAMOND® ATTACHMENTS factory or authorized BLUE DIAMOND® ATTACHMENTS dealership or in any way so as in BLUE DIAMOND® ATTACHMENTS judgment, to affect its stability or reliability, nor which has been subject to misuse, negligence or accident beyond the company recommended machine rated capacity.

### WARRANTY CLAIM

To submit a warranty claim, a claim must be filed with BLUE DIAMOND® ATTACHMENTS before work is performed. The BLUE DIAMOND® PRODUCT SUPPORT TEAM will advise repairs and applicable parts exchanges. Tampering with the failed part may void the warranty. This warranty does not include freight or delivery charges incurred when returning machinery for servicing. Dealer mileage, service calls, and pickup/delivery charges are the customers' responsibility.

### EXCLUSIONS OF WARRANTY

Except as otherwise expressly stated herein, BLUE DIAMOND® ATTACHMENTS makes no representation or warranty of any kind, expressed or implied, AND MAKES NO WARRANTY OF MERCHANTABILITY IN RESPECT TO ITS MACHINERY AND/OR ATTACHMENTS ARE FIT FOR ANY PARTICULAR PURPOSE. BLUE DIAMOND® ATTACHMENTS shall not be liable for incidental or consequential damages for any breach or warranty, including but not limited to inconvenience, rental of replacement equipment, loss of profits or other commercial loss. Upon purchase, the buyer assumes all liability for all personal injury and property resulting from the handling, possession, or use of the goods by the buyer.

No agent, employee, or representative of BLUE DIAMOND® ATTACHMENTS has any authority to bind BLUE DIAMOND® ATTACHMENTS to any affirmation, representation, or warranty concerning its machinery and/or attachments except as specifically set forth herein.

This warranty policy supersedes any previous documents. Please see [bluediamondattachments.com/warranty-policies](http://bluediamondattachments.com/warranty-policies) for the most up to date warranty information.

**NOTE:** Blue Diamond® Attachments is a trademark of BLUE DIAMOND® ATTACHMENTS



**QUALITY | DEPENDABILITY | INTEGRITY**

Blue Diamond® Attachments  
4512 Anderson Road, Knoxville, TN 37918  
888-376-7027