

Heavy Duty Skid Steer Drum Mulcher

Operation and Maintenance Manual



Register your
WARRANTY
within 30 days
of purchase



888-376-7027 | BlueDiamondAttachments.com



BD-092

Introduction: Owner Information

Thank you for your decision to purchase a Blue Diamond® Heavy Duty Skid Steer Drum Mulcher. To ensure maximum performance of your equipment, it is mandatory that you thoroughly study the Operator's manual and follow the recommendations. Proper operation and maintenance are essential to maximize equipment life and prevent personal injury.

Operate and maintain this equipment in a safe manner and in accordance with all applicable local, state, and federal codes, regulations and /or laws. Follow all on-product labeling and instructions.

Make sure that all personnel have read this Operator's Manual and thoroughly understand safe and correct operating, installation and maintenance procedures.

Blue Diamond® is continually working to improve its products. Blue Diamond® reserves the right to make any improvements or changes as deemed practical and possible without incurring any responsibility or obligation to make any changes or additions to equipment sold previously.

Although great care has been taken to ensure the accuracy of this publication, Blue Diamond® makes no warranty or guarantee of any kind, written or expressed, implied or otherwise with regard to the information contained within this manual. Blue Diamond® assumes no responsibility for any errors that may appear in this manual and shall not be liable under any circumstances for incidental, consequential or punitive damages in connection with, or arising from the use of this manual.

Keep this manual available for frequent reference. All new operators or owners must review the manual before using the equipment and annually thereafter. Contact your Blue Diamond® Attachments Dealer for assistance, information, or additional copies of the manual. Contact www.bluediamondattachments.com or call 888-376-7027 for a complete list of dealers in your area.

Serial Number Location:

Please record attachment information in the space provided for future reference.



Model Number: _____

Serial Number: _____

Dealer Name: _____

Dealer Number: _____

Date of Purchase: _____

The serial number plate is located on the left side of the frame.

Always use your serial number when requesting information or when ordering parts.

NOTE: The directions left, right, front and rear, as mentioned throughout this manual, are as viewed from the operator's position.

Revision Date: 06.22.2026

Blue Diamond® Attachments

Table of Contents

Introduction: Owner Information	2	5.12 Drive Side Rotor Bearing Assembly — 290433.....	46
Table of Contents.....	3	5.13 Non-Drive Side Rotor Bearing Assembly — 290429..	47
1. Introduction.....	5	5.14 Rotor Bearing — 290456	48
1.1 Attachment Identification.....	5	5.15 Rotor	49
1.2 About this Attachment.....	6	5.16 Rotor Assembly Parts.....	50
1.3 Attachment Model Numbers.....	6	5.17 Hydraulic Hoses	51
1.4 Key Parts of the Drum		5.18 3-Line Electrical Wire Harness Options	52
Mulcher	7	5.19 3-Line Universal Wire Harness Kit - 290680.....	53
2. Safety	9	5.20 Decals.....	54
2.1 General Safety Information.....	9	6. Specifications	56
2.2 Operators	10	6.1 Attachment Specifications	56
2.3 Operational Safety.....	11	6.2 Torque Specifications	57
2.4 Safety Regulations	13	Warranty	59
3. Start-Up and Operation.....	15		
3.1 General Information	15		
3.2 Attachment Installation.....	16		
3.3 Connecting the Discharge Cover Wire Harness.....	18		
3.4 Initial Set Up Instructions	19		
3.5 Machine Operation.....	22		
4. Maintenance	23		
4.1 Precautions During Maintenance	23		
4.2 Cleaning.....	23		
4.3 Greasing and Lubrication.....	23		
4.4 Hoses and Cylinder	25		
4.5 Belt.....	26		
4.6 Teeth	27		
4.7 Spare Parts.....	27		
4.8 Service Schedule	28		
4.9 Troubleshooting	29		
5. Parts.....	31		
5.1 Main Components.....	31		
5.2 Main Components 2.....	33		
5.3 Main Components 3	35		
5.4 Main Components 4	37		
5.5 Main Frame	39		
5.6 Push Bar Assembly.....	40		
5.7 5-Line Motor and Load Adapter Assembly.....	41		
5.8 3-Line Motor and Load Adapter Assembly	42		
5.9 Overhung Load Adapter — 290442	43		
5.10 Belt Drive — 290438	44		
5.11 Tensioner Plate Assembly	45		

Pre-Delivery Inspection Instructions

Use this checklist to verify safety, function, and readiness prior to delivery.

END USER'S NAME: _____

DATE: _____

ITEM NUMBER & DESCRIPTION: _____

SERIAL NO.: _____

HOST MACHINE MAKE/MODEL: _____

1. Safety & Documentation

- Operation and Maintenance Manual is included.
- Safety decals are present and legible.
- Model and serial number plate is present and intact.
- Verify required hydraulic flow range for customer's host machine.

2. Visual Inspection

- Unit is free of shipping damage, dents, cracked welds, etc.
- Verify motor and safety covers are in place and secure.
- Ensure drive system is correctly lubricated.
- Fasteners are properly torqued.

3. Hydraulic System & Operational Test

- Hydraulic hose routing is appropriate for application.
- Fittings are properly tightened; verify no leakage.

- Quick couplers are correct and clean.
- Case drain line is installed.
- Smooth operation; no hydraulic leaks or excessive vibration of attachment.
- Verify that the rotor speed has been measured within 1800 – 2500 rpms.
- Verify attachment has been connected to the host machine that will be used for operation and tested.
- Verify the host machine's hydraulic flow with a flow meter.

4. Final Delivery

- Maintenance schedule located in Operation and Maintenance Manual has been reviewed.
- Grease type and intervals were provided.
- Teeth change procedure and maintenance safety have been explained.
- Register the attachment for warranty by following the instructions below:
 - Fill out this form and email it to warranty@bdattachments.com

TECHNICIAN: _____

CUSTOMER: _____

DATE: _____

1. Introduction

1.1 Attachment Identification

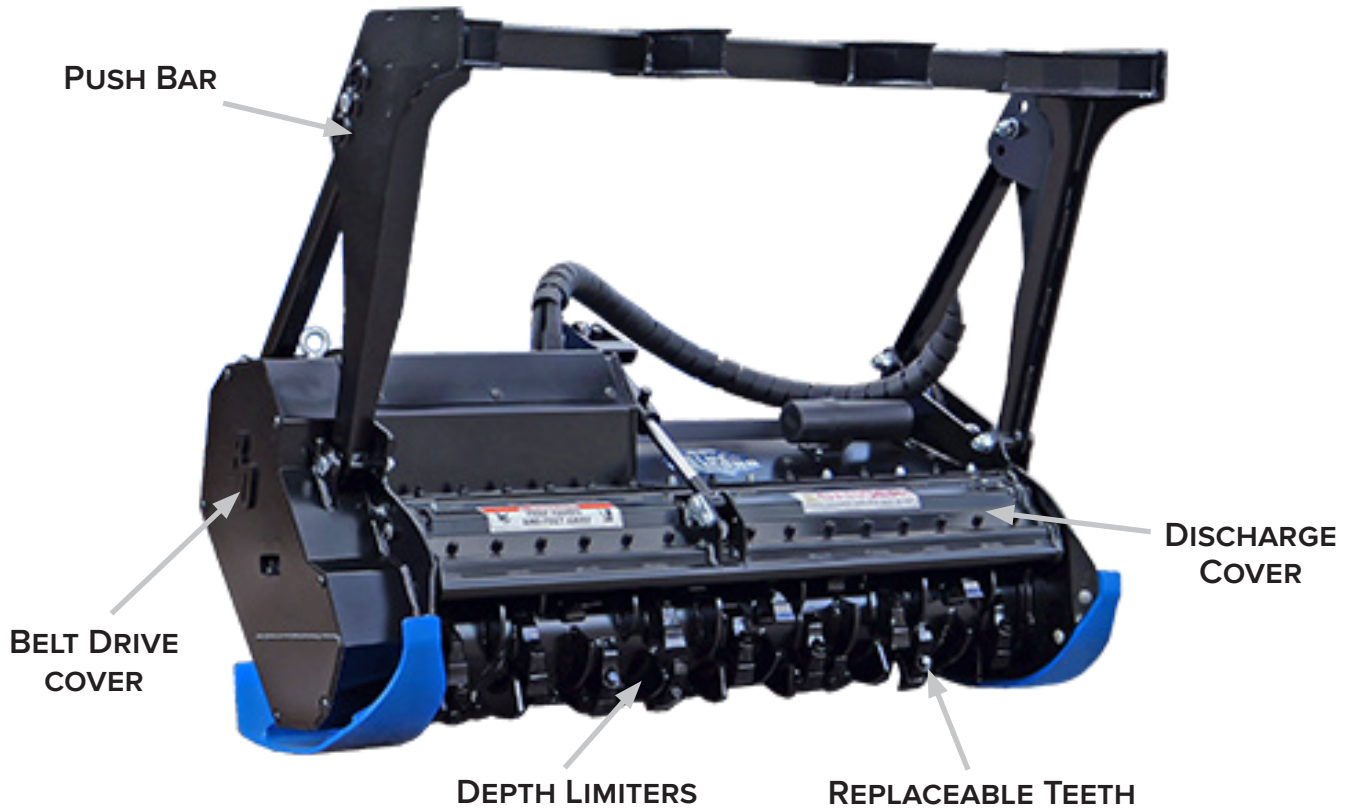

ACCESS COVERS

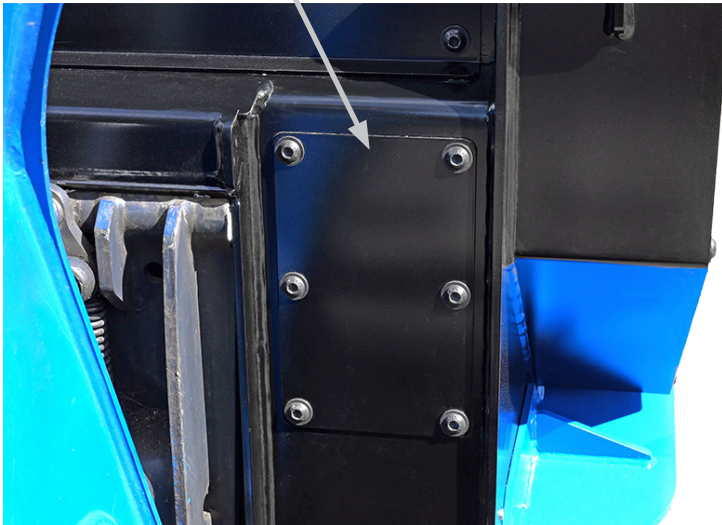

SUPPORT LEG

1. Introduction

1.2 About this Attachment

Blue Diamond® recommends that you carefully read and understand this manual before putting the machine into operation. Follow all safety measures and maintenance procedures described in this manual to ensure proper and efficient use of machine.

NOTE: Blue Diamond® cannot be held liable if specified limits are exceeded.

NOTE: Noise emissions in the environment measured as sound power level (LWA) according to EC directive 2000/14/EC.

The Heavy Duty Skid Steer Drum Mulchers are specially designed for work with skid steers. They meet the highest requirements of the forestry sector, as their configuration and design allow them to perform any work with maximum reliability and efficiency. They are made of high elastic limit steel and coated with wear resistant steel. They also have thermally hardened replaceable counterblades and an optimized rotor for lower power consumption, making them the most reliable hydraulic machines on the market.

Intended Use

The Heavy Duty Skid Steer Drum Mulcher is specially designed for basic clearing, maintenance, and mulching of trees and stumps.



WARNING



If you do not understand any of the points in this manual, do not connect, operate, or service the machine. Immediately contact Blue Diamond® for your own safety and that of the machine.

Sound Pressure Level Indication

NOISE EMISSIONS	dB(A)
Measured sound power level	85
Guaranteed sound power level (LWA)	85

1.3 Attachment Model Numbers



IMPORTANT



DO NOT exceed max flow.

MODEL NUMBER	TEETH	GATE OPTION	COUPLER SIZE
390100	Chipping	3-Line	1/2" Body
390101	Carbide	3-Line	1/2" Body
390102	Chipping	5-Line	1/2" Body
390103	Carbide	5-Line	1/2" Body
390104	Chipping	3-Line	3/4" Body
390105	Carbide	3-Line	3/4" Body
390106	Chipping	5-Line	3/4" Body
390107	Carbide	5-Line	3/4" Body

MOTOR SIZE	FLOW (GPM)	WEIGHT
85cc	22-46	2105 lbs

1. Introduction

1.4 Key Parts of the Drum Mulcher

Discharge Cover with Hydraulic Adjustment

This mulcher is fitted with a hydraulically adjusted discharge cover [Figure 1] (open or close, for more efficient mulching or finer finish).



Figure 1

Rotor

The rotor is responsible for mulching the material and is driven by pulleys.



CAUTION



- Before operating the machine, check that the teeth are correctly fastened.
- Before starting operation of the machine, check that the rotor and its hammers are in good condition.
- Check that there are no objects wrapped around the rotor.

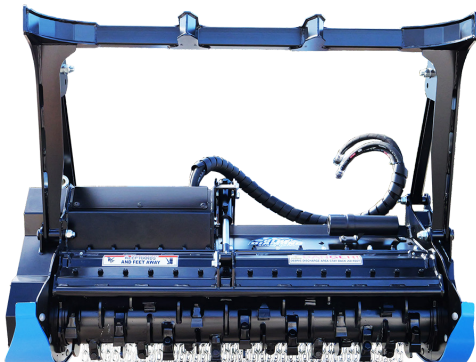

Figure 2

Replaceable Liner

This mulcher features a liner made from high strength steel that is easily replaceable.

Counterblades

The counterblades [Figure 3, Item 1] and the rotor grind and process the material.

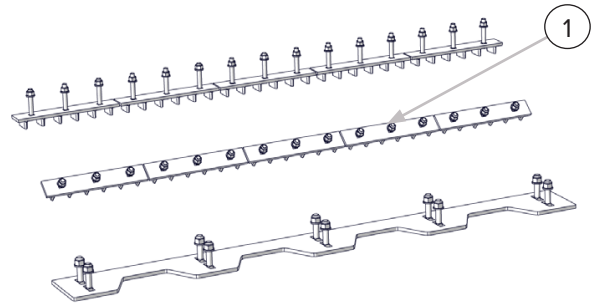

Figure 3

Belt Drive

The belt and pulleys transmit the rotary motion from the gearbox to the rotor.

The belt tension is manually adjusted [Figure 4].



Figure 4

1. Introduction

1.4 Key Parts of the Drum Mulcher (Cont'd)

Replaceable Skid Shoes

This mulcher features skid shoes [Figure 5] made from wear-resistant steel that are easily replaceable.



Figure 5

Hydraulic Motor

The mulcher is powered by hydraulic motor [Figure 6].

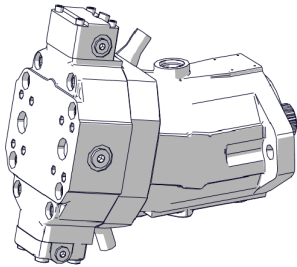

Figure 6

Rear Guarding

The Heavy Duty Skid Steer Drum Mulcher uses chain guards [Figure 7] to prevent mulched material from getting out of control.



Figure 7

Adjustable Intake Plate

This mulcher features an adjustable intake plate [Figure 8] to control the size of material processed.

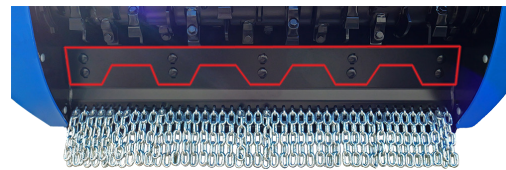

Figure 8

2. Safety

2.1 General Safety Information



This **SAFETY ALERT SYMBOL** identifies important safety messages on the equipment and in the owner's manual. When you see this symbol, be alert to the possibility of personal injury and carefully read the message that follows.



The signal word **IMPORTANT** identifies procedures which must be followed to avoid damage to the machine.



The signal word **DANGER** on the machine and in the manuals indicates a hazardous situation which, if not avoided, will result in death or serious injury.



The signal word **WARNING** on the machine and in the manuals indicates a potentially hazardous situation which, if not avoided, could result in death or serious injury.



The signal word **CAUTION** on the machine and in the manuals indicates a potentially hazardous situation which, if not avoided, may result in minor or moderate injury. It may also be used to alert against unsafe practices.

Operating Safety

- Read and follow instructions in this manual and the machine's Operators Manual before operating.
- The manual must always remain with the machine. In case of loss or damage, request a new copy from your dealer or from Blue Diamond®.
- Strictly follow all rules prescribed by the safety pictograms/decals applied to the machine. Ensure that all safety pictograms/decals are legible. If pictograms/decals are worn, they must be replaced with new ones obtained from Blue Diamond® and placed in the position indicated by this manual.
- Before using the machine, make sure that all safety devices are installed and in good working condition. In case of damage to shields, replace them immediately.
- Remove or alter safety devices and/or safety precautions
- Pay maximum attention to avoid any accidental contact with rotating parts of the machine.
- If the use of the machine is required at night or in conditions of reduced visibility, use the lighting system of the prime mover and possibly an auxiliary lighting system.



Before performing any of the actions in this section, section 2.0 Safety must be read in its entirety and understood fully to avoid any type of risk or accident. If you do not fully understand this manual, **DO NOT** connect or operate the machine or carry out any maintenance operations. Contact your local dealer or Blue Diamond® Product Support immediately to ensure your safety and that of the machine.

NOTE: Notes are used to indicate important information. This information may be repeated in other areas of the manual.

2. Safety



DANGER



- The machine may only be operated, maintained, repaired, serviced, or handled by qualified personnel or an authorized service technician.
- **DO NOT** approach the mulcher, carry out maintenance, inspections, or connect or disconnect components while the machine is running. Before carrying out any of the aforementioned tasks, disengage the hydraulics to stop the rotor. Once the rotor has stopped, rest the mulcher on a level, flat, and firm surface. Park the machine, set the parking brake, turn the machine off, and remove the key from the ignition. Wait until all moving parts have come to a complete stop before approaching the machine.

- The new operator must start in an area without bystanders and use all the controls until he or she can operate the machine safely under all conditions of the work area.

Operator Safety

- Before starting, and during operation of the attachment, make sure there are no people or animals in the operation area; the machine can project material, causing serious injury or death.
- During operation, adjustment, maintenance, repairing, or transportation of the machine, the operator must always use appropriate Personal Protective Equipment (PPE) including, but not limited to, safety glasses, working gloves, dust mask, safety helmet, and hearing protection.
- **DO NOT** operate the attachment or machine while wearing loose fitting clothing that can be caught or entangled in parts of the machine.
- **DO NOT** operate the implement when tired, not in good condition, or under the influence of alcohol or drugs.

2.2 Operators

Qualified Operators

The operator is a person suited to the work and who is physically and psychologically able to withstand the demands connected with operating the equipment for its intended use. The operator must not allow anyone to approach the machine while it is working and must not allow external personnel to operate the machine or attachment.

The operator is to follow the given instructions in this manual and the machine operator's manual in order to obtain maximum performance, minimum consumption, and maximum safety for himself and for others.

The operator is responsible for scrupulously observing all the instructions given in this manual.

Operator Training

- Check the rules and regulations at your location. The rules may include an employer's work safety requirements. Regulations may apply to local driving requirements or use of a Slow Moving Vehicle (SMV) emblem. Regulations may identify a hazard such as a utility line.

2. Safety

2.3 Operational Safety

Operating Safety

- Follow all laws and regulations in your jurisdiction when operating and maintaining your equipment.
- Users must strictly observe all safety regulations indicated in this user manual and all warning signs indicated on the machine.
- Correct use of the machine implies compliance with all maintenance and operating instructions described in this manual and the use of original Blue Diamond® spare parts.
- Prolonged use of the machine causes components to become hot, and there is a burn hazard from direct contact with them. Avoid direct contact with the machine until these components have cooled down.
- DO NOT handle hydraulic components until the pressure in the hydraulic circuit has been relieved. Avoid direct contact with the machine until these components have cooled down.
- The operator must ensure at all times that there are no persons, animals, or obstacles within 1000 feet (300 meters) of the machine's location while in operation.
- Make sure that the machine is in a proper state of repair (cleaning), maintenance (lubrication), and components.
- If the machine vibrates, behaves strangely, or makes unusual noises, stop operation and contact your local dealer or Blue Diamond® Product Support immediately.
- When operating on sloping terrain, check that you are working safely and that there is no risk of tipping over.
- The machine must be stopped and inspected for damage after striking an object. In the event of damage, it must be repaired before continuing with the machine operation.

Operator Training

- Read and follow instructions in this manual and the machine's Operators Manual before operating.
- Under no circumstances should young children be allowed to work with this equipment.
- This equipment is dangerous to persons unfamiliar with its operation.
- Check for overhead and/or underground utility lines before operating equipment (if applicable).
- In addition to the design and configuration of equipment, hazard control, and accident prevention are dependent upon the awareness, concern, prudence, and proper training of personnel involved in the operation, transport, maintenance, and storage of equipment.
- Check that the attachment is securely fastened to the machine.
- Make sure all the machine controls are in the NEUTRAL before starting the machine.
- Operate the equipment only from the operator's position.
- Operate the equipment according to the Operator's Manual.
- When learning to operate the equipment, do it at a slow rate in an area clear of bystanders.
- DO NOT permit personnel to be in the work area when operating the equipment. This attachment discharges debris that can be hazardous.
- The equipment must be used ONLY on approved machines.
- DO NOT modify the equipment in any way. Unauthorized modification may impair the function and/or safety and could affect the life of the equipment.
- DO NOT make any adjustments or repairs on the equipment while the machine is running.
- Keep shields and guards in place. Replace if damaged.

2. Safety

2.3 Operational Safety Cont'd

- DO NOT operate equipment in poor visibility conditions such as fog, darkness, or any conditions that limit clear visibility less than 1000 feet (300 meters) in front of and to the sides of the equipment.
- When conditions make it necessary to slow ground speed, shift to a lower gear rather than reducing engine speed. The engine will maintain rated speed and keep cutter running at optimal cutting speed.
- DO NOT operate in a work area that has not been inspected for foreign debris and obstacles.
- Remove any foreign objects, and clearly mark any objects that cannot be removed.
- Wear safety glasses, gloves, hearing protection, and other protective clothing when required.
- DO NOT position and work with the rotor facing the operator's cab.

Machine Requirements and Capabilities

- The machine operator's cab should be equipped with a thermoplastic polycarbonate or similar material front window, and similar protection on the sides of the operator's cab before operating the equipment.
- Keep bystanders clear of moving parts and the work area. Keep children away.
- DO NOT exceed 5500 psi (380 bar) operating pressure.
- Use caution on slopes and near banks and ditches to prevent overturn

Fire Prevention Safety

- Flammable debris (leaves, grass, etc.) must be removed regularly. If flammable debris is allowed to accumulate, it can cause a fire hazard. Clean often to avoid this accumulation.
- The equipment's hydraulic motor compartment must be inspected every day and cleaned if necessary to prevent fire hazards and overheating.
- All fuels, most lubricants, and some coolant

mixtures are flammable. Flammable fluids that are leaking or spilled onto hot surfaces or onto electrical components can cause a fire.

- Power equipment can cause sparks and start fires. Be especially careful on hot, dry days. Exercise caution while operating and watch for sparks.
- Keep a working fire extinguisher and shovel should be kept near the working area.

Transporting Safety

- Blue Diamond® Attachments cannot be held responsible for any damage due to transport that was carried out by the customer and/or operator or by carriers chosen by the customer and/or operator.
- Comply with state and local laws governing highway safety and movement of machine on public roads.
- Check local laws for all highway lighting and marking requirements.
- Always yield to oncoming traffic and move to the side of the road so any following traffic may pass.
- Never allow riders on either machine or equipment.
- If transporting the drum mulcher on a truck or trailer, make sure the drum mulcher is properly secured to the transport vehicle.

2. Safety

2.3 Operational Safety Cont'd

Hydraulic System

- Check hydraulic tubes, hoses, and fittings for damage and leakage. Never use open flame or bare skin to check for leaks. Hydraulic tubes and hoses must be properly routed and have adequate support and secure clamps. Tighten or replace any parts that show leakage.
- Always clean fluid spills. Do not use gasoline or diesel fuel for cleaning parts. Use commercial nonflammable solvents.



WARNING



Leaking fluids under pressure can enter the skin and cause serious injury or death. Immediate medical attention is required.
Wear goggles. Use cardboard to check for leaks.

2.4 Safety Regulations

Precautions and Hazards during Machine Operation

- When moving the machine from the transport position to the working position, the operator must keep all persons and animals in the operation area at least 1000 feet (300 meters) away from the outer contour of the machine.
- Keep away from crushing or shearing zones between moving parts driven by mechanical, hydraulic, or pneumatic power.
- DO NOT operate the machine without its safety devices and guards in place.
- DO NOT operate the machine if the safety devices and guards are not in perfect condition. Replace them before continuing to work with the machine.
- DO NOT climb on the machine while it is in operation or when it is off.
- DO NOT start the mulcher rotor without first raising the machine off the ground.

- DO NOT transport persons or animals or to load or transport goods on the machine.
- DO NOT exceed the machine's power capacity as specified by the manufacturer.
- Keep a sufficient distance from utility lines and pipes.
- When the mulcher is in operation, fire may occur. Keep a fire extinguisher nearby the work area.



DANGER



- Before any maneuver, the operator must ensure that there are no persons, animals, or obstacles within 1000 feet (300 meters) of the machine's location.
- DO NOT work with the machine at a distance of less than 1000 feet (300 meters) from roads on which motor vehicles, lorries, or horse-drawn vehicles may travel if the operator does not comply with all the safety procedures in this manual.
- DO NOT work with the machine at a distance of less than 1000 feet (300 meters) from public areas (parks and/or gardens), civil, residential, or industrial buildings if the operator does not comply with all the safety procedures in this manual.
- DO NOT handle hydraulic hoses and connections when the machine is running, as there is a high risk of penetration into the skin and eyes due to oil pressure.



WARNING



Leaking fluids under pressure can enter the skin and cause serious injury or death. Immediate medical attention is required.
Wear goggles. Use cardboard to check for leaks.

2. Safety

2.4 Safety Regulations Cont'd



Precautions and Hazards during Machine Operation Cont'd

- DO NOT leave the machine unless the rotor of the mulcher is stopped, the machine is placed on a flat, level, and firm surface, parking brake is engaged, the machine is off, and the key is removed from the ignition.
- Use Blue Diamond® approved spare parts for better performance and increased safety.

Precautions during Maintenance

- Refer to the user manual of the machine.
- A qualified operator must carefully read the entire safety manual and fully understand and follow the information before connecting or disconnecting the machine.
- Use appropriate PPE including but not limited to eye and ear protection, work gloves, work boots, safety hat, dust mask, and work clothes.
- The machine may only be operated, maintained, repaired, serviced, and/or handled by qualified personnel or an authorized service technician.
- DO NOT conduct maintenance work while in the field. All maintenance must be completed as authorized technical service in the proper environment with all safety precautions.
- DO NOT stand between the skid steer and the machine.
- Before carrying out any maintenance, all hardware (fittings, screws, nuts, bolts, pins, etc.) must be checked for tightness to prevent moving parts from coming loose on the operator.

- There is a risk of leaks in hoses or hydraulic components.

**WARNING**



Leaking fluids under pressure can enter the skin and cause serious injury or death. Immediate medical attention is required.

Wear goggles. Use cardboard to check for leaks.

Storage of the Machine

- When the machine is not in operation and must be stored for a certain time, the mulcher must be separated from the skid steer according to all the safety rules in this manual.
- For storage, the mulcher must be placed on a level, flat, and firm surface.
- It is advisable to store the machine in a covered and dry place.
- Before storing the machine, clean, dry, and lubricate all components.
- Always use original greases and lubricants recommended by Blue Diamond®.
- Once the machine has been positioned and cleaned on a flat, level, and firm surface, a general inspection must be made to ensure that there are no anomalies (ie., condition of the teeth).
- Before storage, check that all fasteners (fittings, screws, nuts, pins, bolts, etc.) are tight, and check for leaks in the hydraulic circuit.
- Use original Blue Diamond® spare parts for better performance and increased safety.
- Check that the safety decals are in perfect condition. Otherwise, replace them before operating the machine.
- When operating or maintaining the machine again, the safety rules mentioned in this manual must be followed.

3. Start-Up and Operation

3.1 General Information

Before starting up the machine, the operator must carefully read and understand the installation and operating instructions of the machine.



WARNING



Before performing any of the actions in this section, section 2.0 Safety in this manual must be read in its entirety and understood fully to avoid any type of risk or accident. If, after reading this manual, you do not understand any point, **DO NOT** connect or operate the machine or carry out any maintenance operations. Contact your local dealer or Blue Diamond® Product Support immediately to ensure your safety and that of the machine.

Pre-Operation Inspection

Before operating the Heavy Duty Skid Steer Drum Mulcher for the first time and each time thereafter, use the following list as a guideline during equipment inspection.



WARNING



AVOID SERIOUS INJURY OR DEATH

- Disengage machine's auxiliary hydraulics, engage the machine's parking brake, stop the engine and make sure all rotating components are completely stopped before connecting, disconnecting, adjusting or cleaning equipment.
- Always keep shields and all guards in place when using the equipment.
- Disengage machine's auxiliary hydraulics for road travel.
- Keep hands, feet and clothing away from rotating parts.

Fully clean the attachment. See "4.2 Cleaning" on page 23.

- Lubricate the attachment per the schedule outline in the Maintenance Section. See "4.8

Service Schedule" on page 28.

- Check the drum mulcher mounting plate for damage. Check for loose or missing parts. Repair as needed before operation.
- Check that teeth are in good condition. Sharpen or replace them, if necessary.
- Check that all shields and guards are in place.
- Check for loose bolts and tighten them if necessary.
- Check all welds on the attachment for wear and damage each time the attachment is removed from the machine.
- Check for damaged or missing safety decals. Replace if necessary.
- Inspect the machine's mounting frame. (See the machine's Operator's Manual for inspecting the mounting frame). Replace any parts that are damaged, bent, or missing. Keep all fasteners tight. Look for cracked welds.



WARNING



Leaking fluids under pressure can enter the skin and cause serious injury or death. Immediate medical attention is required.

Wear goggles. Use cardboard to check for leaks.

- Check condition of all hydraulic components for leaks. Repair as required.

NOTE: DO NOT operate with hydraulic leaks

- Verify that the drum mulcher is properly connected to the machine.

3. Start-Up and Operation

3.2 Attachment Installation

IMPORTANT



See the machine's Operator's Manual for detailed information on operating the loader.

Entering The Operator's Position

Use the attachment safety treads, handles and steps (on the machine) to enter the operator's position.

When in the operator's position, lower safety seat bar, start the engine and release the parking brake.

Leaving The Operator's Position

WARNING

AVOID SERIOUS INJURY OR DEATH

- Always park on a flat, level surface.
- Lower lift arms and place attachment flat on the ground.
- Place all controls in **NEUTRAL**.
- Engage the parking brake.
- Stop the engine, and remove the key.
- Wait for all moving parts to stop.

SEE MACHINE'S OPERATOR'S MANUAL FOR ADDITIONAL INFORMATION.

Park the machine / attachment on a flat level surface.

Place all controls in neutral, engage the park brake, stop the engine, and wait for all moving parts to stop. Leave the operator's position.

Connecting Attachment To The Machine

WARNING



CRUSH HAZARD

- Before moving the machine, look in all directions and make sure no bystanders, especially small children are in the work area. Do not allow anyone between the machine and attachment when approaching the attachment for connecting.
- Keep fingers and hands out of pinch points when connecting and disconnecting the attachment.

Before connecting to the attachment, inspect the machine's mounting plate. (See the machine's Operator's Manual for inspecting the mounting frame).

Enter the operator's position. See "Entering The Operator's Position" on page 16.

Drive the machine slowly forward, until the top edge of the machine's mounting plate is under the top flange of the attachment mounting frame.

Slowly tilt the machine's mounting plate back until the attachment mounting frame fully contacts the front of the machine's mounting plate.

Leave the operator's position. See "Leaving The Operator's Position" on page 16.

3. Start-Up and Operation

3.2 Attachment Installation Cont'd

Connecting Attachment to the Machine Cont'd



WARNING



AVOID SERIOUS INJURY OR DEATH

The locking pins / wedges must extend through the holes in the attachment mounting frame. Failure to secure locking pins / wedges can allow attachment to come off.

**SEE MACHINE'S OPERATOR'S MANUAL FOR
ADDITIONAL INFORMATION.**

Engage attachment locking levers / wedges (See the machine's Operator's Manual for detailed information).

Connecting Hydraulic Hoses



IMPORTANT



Thoroughly clean the quick couplers before making connections. Dirt can quickly damage the hydraulic system.

Remove dirt or debris from the male and female couplers. Visually inspect the couplers for corroding, cracking, damage, or excessive wear. Replace as needed.

Connect the attachment hydraulic hoses to the machine. The hydraulic hoses must be connected in the following order: case drain, return hose, and pressure hose.

Pull on each hose to verify full connection is made.



IMPORTANT



The case drain **MUST** be connected to the machine; otherwise, it will result in damage to the attachment.

Disconnecting Hydraulic Hoses



WARNING



AVOID SERIOUS INJURY OR DEATH

Hydraulic fluid, tubes, fittings, and quick couplers can get hot during operation. Be careful when connecting and disconnecting hydraulic hoses.

Relieve auxiliary hydraulic pressure. (See the machine's Operator's Manual for correct procedure.)

Disconnect attachment hydraulic hoses from the machine. The hoses must be disconnected in the following order: pressure hose, return hose, and case drain.

Disconnecting Attachment From the Machine

Relieve auxiliary hydraulic pressure. (See the machine's Operator's Manual for correct procedure.)

Park the machine and attachment on a flat level surface. Lower the attachment flat on the ground.

Leave the operator's position. See "Leaving The Operator's Position" on page 16.

Disconnect attachment hydraulic hoses from the machine.

Disengage locking pins / wedges. (See the machine's Operator's Manual for correct procedure.)

Enter the operator's position. See "Entering The Operator's Position" on page 16.

Slowly tilt the machine's mounting plate forward until the attachment mounting frame is free from the machine's mounting plate.

Drive the machine slowly backward, away from the attachment.

3. Start-Up and Operation

3.3 Connecting the Discharge Cover Wire Harness

The discharge cover is controlled by electro-hydraulic inputs, using 12V power from the machine battery to a hydraulic diverter valve, operated from the cab with a control switch or the machine joystick controls.

Ensure there is no power flowing to the valve block and the skid steer is powered off when assembling the wire harness.

If using a machine control harness, follow the assembly steps below.

1. Connect the Delphi adapter harness segment to the Delphi connector on the attachment harness.
2. Connect the machine control harness adapter to the Delphi adapter harness, and connect to the machine auxiliary electrical connection.

If using the universal control box harness, follow the assembly steps and refer to the illustrations on **“5.19 3-Line Universal Wire Harness Kit - 290680”** on page 53 for guidance.

3. Connect the Delphi adapter harness segment to the Delphi connector on the attachment harness.
4. Mount the control switch box in a convenient location inside the skid steer cab.
5. Route the control leg from the control box segment out of the cab through the engine compartment to the pivot point and down the lift arms.
6. Route the attachment and Delphi adapter segments up the boom from the attachment, and connect it to the control leg where they meet. Coil excess harness length in the open space of the mulcher body.
7. Route the power leg of the control box segment towards either the 12V power plug connection inside the cab, or towards the machine battery. Connect the 12V plug segment or the battery terminal segment, using extensions as required, and connect to the power source.



IMPORTANT



Zip-tie the harness to the skid steer hoses or other available points for routing along the boom. Route the harness in such a way that it will not be stretched, pinched, or otherwise damaged by the movement of the boom or attachment.

3. Start-Up and Operation

3.4 Initial Set Up Instructions

⚠ WARNING ⚠

Read and follow completely before operating or using the mulcher in any capacity.



Figure 9

TOOLS NEEDED	PURPOSE
6,000 PSI Pressure Gauge	Pressure Measurement
Laser Tachometer and Reflective Tape	Speed Measurement
19mm Open Head Wrench	Displacement Adjustment
10mm Open Head Wrench	Shift Pressure Adjustment
8mm Allen Key	Access Plates
6mm Allen Key	Displacement Adjustment
3mm Allen Key	Shift Pressure Adjustment

Hydraulic Connections

- P: Pressure
- R: Return
- D: Case Drain
- MP: Working Pressure Gauge Port

1. Connect the case drain hose.
2. Connect the return hose.
3. Connect the pressure hose.

NOTE: Disconnect in reverse order.

⚠ IMPORTANT ⚠

The case drain **MUST** be connected to the skid steer, otherwise it will result in damage to the drum mulcher.

⚠ WARNING ⚠

AVOID SERIOUS INJURY OR DEATH

Keep away from moving parts.

⚠ WARNING ⚠

Disengage the hydraulics and wait for all moving parts to stop before performing any adjustments. Place the mulcher on a firm, level surface before performing any maintenance procedures.

3. Start-Up and Operation

3.4 Initial Set Up Instructions Cont'd

Adjust Shift Pressure



WARNING



AVOID SERIOUS INJURY OR DEATH

Keep the discharge area clear of personnel, bystanders, or damageable property.

Measure System Relief Pressure

1. Set the mulcher firmly on the ground with the rotor blocked to prevent rotation.
2. Attach the pressure gauge to the MP port (see **Figure 10**, Item 1).

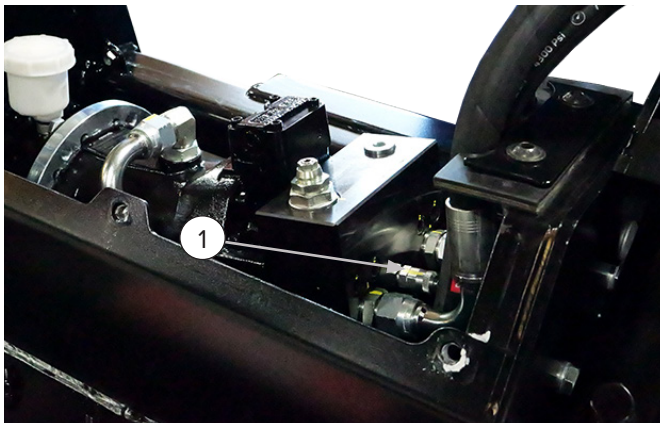

Figure 10

3. Engage the auxiliary hydraulics at full pressure to determine the maximum system pressure.

NOTE: DO NOT engage the hydraulics for more than 30 seconds to avoid heat build up in the hydraulic system.

Measure Shift Pressure

1. With the hydraulics disengaged and the pressure gauge still installed, lift the mulcher clear of the rotor block and anything else that might be caught or entangled in the rotor.
2. With the rotor completely still, engage the hydraulics at full flow and pressure. As the rotor builds speed, the pressure reading on the gauge will spike to the system relief pressure and then begin to fall. The gauge will slow and pause momentarily at a slightly lower reading, and then continue falling to a working pressure of around 600 – 700 PSI. The shift pressure is the level at which the gauge paused. If the shift pressure reading is not 70 – 80% of the system relief pressure, it can be adjusted for a better mulching experience.

Adjust Shift Pressure

1. Disengage the auxiliary hydraulics, wait for all moving parts to stop, and set the mulcher on a flat, level, and firm surface.
2. Remove the top cover plate at the top of the mulcher and the cap off of the adjustment screw on top of the motor. See **Figure 11**, Item 1.

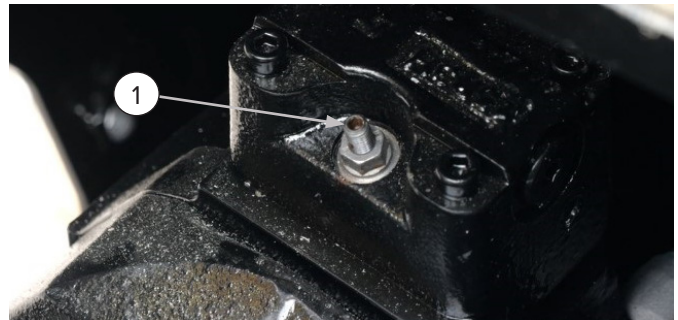

Figure 11

3. Loosen the jam nut, and turn the 3mm allen key to adjust. A half turn is equal to 1,160 PSI.

DIRECTION	SHIFT PRESSURE
Clockwise	Decrease
Counterclockwise	Increase

4. Hold the allen key in place, and tighten the jam nut. Repeat the above steps for measurement and adjustment until the desired shift pressure is reached.

3. Start-Up and Operation

3.4 Initial Set Up Instructions Cont'd

Adjust Rotor Speed

The minimum displacement of the motor may need adjusted to match the auxiliary flow of the machine.

The motor displacement varies between 55cc (factory setting) and 85cc. The lower displacement can be decreased from the factory setting.

Measure Rotor Speed

1. Remove the side cover to access the rotor pulley.

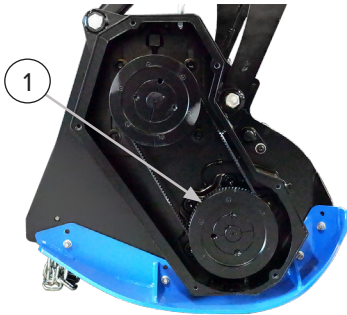

Figure 12

2. Apply reflective tape to the rotor pulley **Figure 12**, Item 1.
3. Engage the rotor. Use a tachometer to measure the speed. The rotor speed should be between 1800 – 2500 rpm. If the rotor speed is not between the stated range, adjust the displacement.

NOTE: Rotor speed may decrease as hydraulic oil temperature increases.



WARNING



Disengage the hydraulics and wait for all moving parts to stop before performing any adjustments. Place the mulcher on a firm, level surface before performing any maintenance procedures.

Adjust Displacement

1. Disengage the auxiliary hydraulics, wait for all moving parts to stop, and set the mulcher on a flat, level, and firm surface.
2. Remove the access cover on the rear of the mulcher to access the motor. See **Figure 13**, Item 1.



Figure 13

3. Loosen the jam nut, and turn the allen bolt to adjust the minimum displacement. Tighten the jam nut when complete. See **Figure 14**, Item 1.

DIRECTION	MINIMUM DISPLACEMENT	ROTOR SPEED
Clockwise	Increase	Decrease
Counterclockwise	Decrease	Increase

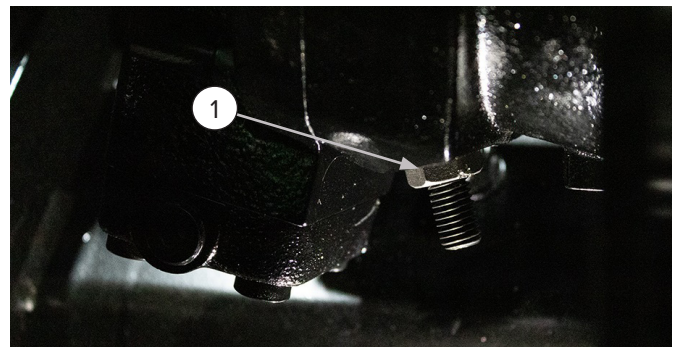

Figure 14

4. Measure the rotor speed again, and adjust as needed.

3. Start-Up and Operation

3.5 Machine Operation



WARNING



- DO NOT start the mulcher rotor without first raising the machine off the ground.
- The movement of the skid steer arm must be as near to the ground as possible to avoid the risk of overturning.

Mulching Procedure

- When the skid steer is powered on and auxiliary hydraulics engaged, use the control switch or machine joystick controls to open or close the discharge cover. Open the discharge cover to expose the rotor while moving forwards to mulch a greater volume during primary mulching. Close the discharge cover while moving backwards for a finer finish during secondary mulching.
- DO NOT put pressure on the mulcher when it is on the ground. This could damage the machine.
- For best results, find the balance between speed, power, and material mulched.

Alignment of the Machine to Terrain

- During operation, DO NOT put excessive weight or pressure on the mulcher, to prevent damage.

Turning with the Machine

- When changing direction, avoid abrupt maneuvers that can cause damage to the machine components that come into contact with the ground.
- Lift the machine slightly and perform the rotation or direction change. Once the maneuver is completed, lower the machine carefully without applying pressure to the mulcher with the skid steer arm to continue operation.

4. Maintenance

Before carrying out any maintenance operations, the operator must carefully read and understand the instructions contained in this manual.

Regular and thorough maintenance keeps the machine in optimal condition and prolongs its service life.



WARNING



Before performing any of the actions in this section, section 2.0 Safety in this manual must be read in its entirety and understood fully to avoid any type of risk or accident. If, after reading this manual, you do not understand any point, **DO NOT** connect or operate the machine or carry out any maintenance operations. Contact your local dealer or Blue Diamond® Product Support immediately to ensure your safety and that of the machine.

4.1 Precautions During Maintenance

- If a safety device is removed during maintenance of the machine, it must be replaced and checked for correct operation of the machine.
- Check that the safety symbols are in perfect condition. Otherwise, replace them before operating the machine.
- Before and after all maintenance work on the machine, check that all hardware (fittings, screws, nuts, pins, bolts, etc.) are tight, and check for leaks in the hydraulic circuit.
- Before carrying out any welding work (with Blue Diamond's approval) on the machine, the mulcher must be disconnected from the skid steer.
- Cleaning of the mulcher and its parts must be done with the machine stopped and disconnected from the skid steer.
- **DO NOT** throw away, dump, or burn products that could pollute the environment.
- Blue Diamond® shall not be held responsible in the event of poor waste management by any maintenance personnel.

- Use original Blue Diamond® spare parts for better performance and increased safety.
- Always use original greases and lubricants recommended by Blue Diamond®

4.2 Cleaning

- Before conducting any maintenance work on the machine, a general cleaning of the working area must be carried out.
- Remove items such as branches, twigs, ropes, wires, or cables from the rotor.
- Remove brush, wood chips, or mulched material from the top of the machine.
- Clean the inside walls of the machine and the teeth according to the **“4.8 Service Schedule” on page 28**.
- Before greasing, clean the grease zerks.
- Use the lubricants listed in this manual.

4.3 Greasing and Lubrication

Lubrication of the machine is simple and can be performed by the operator following the instructions in this manual and the following recommendations:

- Lubrication and greasing of moving components is essential to prevent friction between moving and stationary bodies.
- Excessive lubrication and greasing can be harmful, so the intervals and quantities specified in these instructions must be observed.
- The use of approved PPE is mandatory for this operation. The safety measures to be followed during the greasing process are indicated on the greasing container.



CAUTION



The greases and oils must be disposed of in accordance with the local regulations. Blue Diamond® cannot be held responsible for improper waste disposal.

4. Maintenance

4.3 Greasing and Lubrication Cont'd



- Clean grease zerks prior to greasing.
- Use LITHIC SYNTHETIC EP NI GI grade 2 grease or equivalent.

Lubrication of the Machine

- The lubrication points are shown in **Figure 15-1**, **Figure 15-2** and **Figure 15-3**.

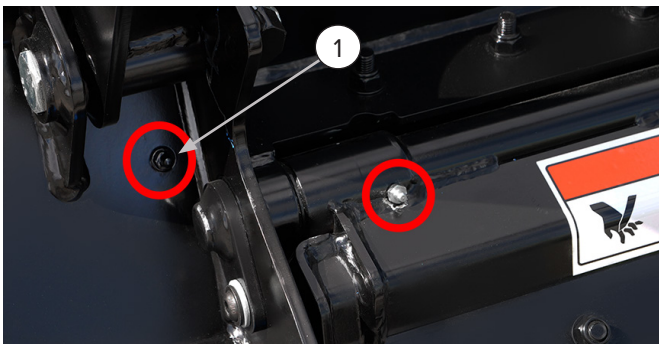

Figure 15-1



Figure 15-2



Figure 15-3

- The grease zerks Item 1 **Figure 15-1** for the rotor bearing housings should be lubricated every 4 hours by applying 10 pumps or every 8 hours by applying 20 pumps using the grease pump. The rotor bearing and cover zerks **Figure 15-1** are on both ends.
- Apply grease to the cylinder and discharge cover zerks every 8 hours until the fresh grease squeezes out.
- After greasing, remove any grease residue from the surface of the machine.

Oil Level Check



Checking, draining, and refilling the oil must be done by qualified personnel or an authorized technical service.

- Overhung load adapter oil level should be checked every 20 hours.
- Stabilize the machine on a level, flat and firm surface.
- Clean the area around the level plug to prevent dirt from contaminating the oil.
- Remove the level plug.
- If the plug is removed and the oil level is at the lower edge of the hole, the oil level is correct.
- If the oil level is too low, follow the “Oil Fill” on page 25.

OIL EXPANSION TANK AND FILLER CAP

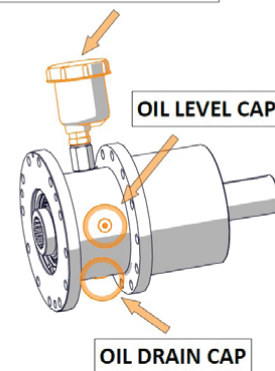

4. Maintenance

4.3 Greasing and Lubrication Cont'd

Oil Drain



CAUTION



Grease and oils must be disposed of in accordance with the waste regulations in force. Blue Diamond cannot be held responsible for improper waste disposal by the personnel performing the maintenance.

- Drain and refill the load adapter oil every 250 hours or yearly.
- Stabilise the machine on a level, flat and firm surface.
- Before each drain, engage the rotor for a few minutes to raise the oil temperature and ensure that the oil has good viscosity for proper drainage.
- Unscrew drain cap, drain oil and confirm that it has been completely removed.

Oil Fill

- Clean the area around the level plug and filler plug to prevent dirt from contaminating the oil.
- Remove the level plug and filler cap.
- Using a funnel, pour oil into the fill hole until it comes out of the level hole.
- Use Shell Rimula R5 LE oil Viscosity SAE USER MANUAL_ 57 10W 40 (API: CI-4, CH-4, CG-4, CF-4; ACEA: E7, E5, E3).
- Allow excess oil to drain through the level hole, and screw the level plug and filler plug back into place.
- Wipe off any oil residue that may remain on the surface of the machine.

4.4 Hoses and Cylinder

- Every 20 hours check the hoses and cylinder for oil leaks.
- Check the hydraulic hoses for cracks that could lead to leaks.
- Check the piston rod on the cylinder for scratches that could damage the seals.

NOTE: Use original Blue Diamond® spare parts for better performance and increased safety.



IMPORTANT



If the cylinder can be moved manually without machine input, stop operation and contact Blue Diamond® Product Support.

4. Maintenance

4.5 Belt

The Heavy Duty Skid Steer Drum Mulchers use a polychain carbon fiber belt **Figure 16** with a manual tensioning system.



Figure 16

NOTE: Apply the force indicated in the table with the tensiometer at the midpoint of the center-to-center distance (Point A) **Figure 17**

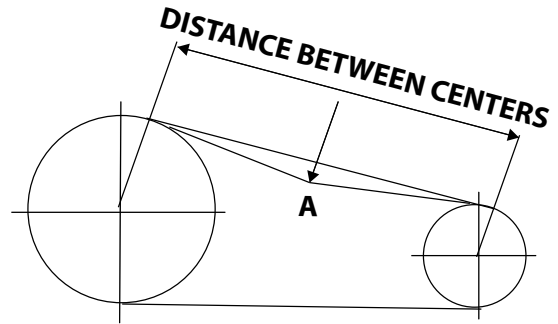

Figure 17

Manual Tensioning System For Polychain Belt

- After the first 5 hours of operation, check the tension and condition of the belt.
- Every 50 hours, check the tension and condition of the belt.
- The belt is properly tensioned when the deflection in the center of the span (Point A) **Figure 17** is equal to the deflection distance shown in the table when the deflection force shown is applied with a tensiometer.

HEAVY DUTY MODEL PARAMETERS	NEW BELT	USED BELT
STRAND DEFLECTION FORCE	33-36 lbs ft (15-16.2 Kgf)	25-28 lbs ft (11.3-12.5 Kgf)
STRAND DEFLECTION DISTANCE	.25 IN (6.25MM)	.23 IN (5.9MM)

! **DANGER** !

Belt tensioning must be done by qualified personnel or an authorized service technician.

Belt Replacement

- Replace worn or broken belt.

NOTE: Use original Blue Diamond® spare parts for better performance and increased safety.

4. Maintenance

4.6 Teeth

The Heavy Duty Skid Steer Drum Mulchers can use chipping or carbide teeth.

Chipping Teeth Figure 18

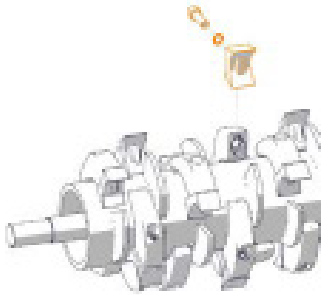

Figure 18

Carbide Teeth Figure 19



Figure 19

- See section “**6.2 Torque Specifications**” on **page 57** for the proper tightening torque that must be applied to the screws that secure the teeth.
- After the first 5 hours of operation, check the torque of the teeth as indicated in “**6.2 Torque Specifications**” on **page 57**.
- After every 20 hours, check the torque of the teeth as indicated in section “**6.2 Torque Specifications**” on **page 57**.
- Every 8 hours clean the teeth.
- **DO NOT** operate the machine with worn teeth as this may cause damage to the rotor.
- When replacing one or more teeth, replace all teeth to maintain the balance of the rotor.
- Stop operating the machine immediately if you notice any abnormal vibration of the rotor or

machine. Contact Blue Diamond® immediately or an authorized technical service.



DANGER



The replacement of teeth and tightening torque of teeth must be carried out by qualified personnel or an authorized service technician.

- **NOTE:** Use original Blue Diamond® spare parts for better performance and increased safety.

4.7 Spare Parts

- To order a spare part, the customer must contact an authorized Blue Diamond® dealer.
- The customer must provide the authorized dealer with the machine model and serial number.

4. Maintenance

4.8 Service Schedule

DESCRIPTION	Every 4h	After first 5 hours	Every				250h
			8h	20h	40h	50h	
Cleaning / Maintenance							
*Teeth			•				
Machine				•			
Checking							
Condition of teeth	•						
*Seals	•						
*Belt		•				•	
*Overhung Load Adapter				•			
Adjusting							
*Teeth		•		•			
*Tooth holders and hardware				•			
*Other machine hardware		•				•	
*Belt		•				•	
Greasing **							
*Rotor bearing housings	•						
*Cylinder Pin			•				
*Overhung Load Adapter							•

* For these tasks Contact your dealer or Blue Diamond® Product Support.

** Refer to “4.3 Greasing and Lubrication” on page 23 for interval.

4. Maintenance

4.9 Troubleshooting

PROBLEM	CAUSE	SOLUTION
Abnormal vibrations of the machine.	Unevenly worn teeth.	Replace all teeth with new ones.
	Unbalanced rotor.	Have the rotor balanced, Contact your dealer or Blue Diamond® Product Support.
	Accumulation of debris or rolled-up elements on the rotor.	Check the rotor for dirt or other unbalance-causing elements.
	Loss of one or more of the teeth.	Replace the teeth.
	Rotor bearings damaged or broken.	Replace the rotor bearings with new ones.
Poorly mulched material or poor finish.	The rotor does not reach the intended speed.	Check the tension of the belt. Contact your dealer or Blue Diamond® Product Support.
	Adjustment of the machine not in accordance with the instructions.	Check the manufacturer's recommended power take-off RPM.
	High ground speed.	Reduce the working speed and adjust it to the working conditions.
	Worn teeth.	Replace worn teeth with new ones.
	Wrong working height.	Adjust the height of the skid shoes.
Excessive wear of the rotor and teeth.	Incorrect machine height. (Excessive working depth.)	Adjust the height of the skid shoes.
High power consumption.	Too much material.	Reduce speed.
	High ground speed.	Reduce the working speed and adjust it to the working conditions.
	High working depth.	Adjust the working height of the skid shoes.
Loud and continuous noise during operation of the machine.	Low oil level in the skid steer tank.	Check hydraulic oil level, and check for leaks.
Broken seals.	Lack or excess of lubrication.	Lubricate correctly, respecting the times indicated in this manual.
	Wear and tear.	Replace broken seals with new ones.
	Mechanical problems in bearings or shafts near the seal.	Replace damaged components.
Frequent bearing breakage.	Frame bent with excessive axial loads.	Contact your dealer or Blue Diamond® Product Support.
	Lack of lubrication.	Lubricate according to the times indicated in this manual.
	Machine overloaded.	Respect the working limits indicated by the manufacturer (in case of doubt, contact your dealer or Blue Diamond® Product Support).
	Incorrect rotor mounting or adjustment.	Check assembly and adjustments.
	Excessive vibrations due to unbalance in the rotor.	Contact your dealer or Blue Diamond® Product Support.

4. Maintenance

4.9 Troubleshooting Cont'd

PROBLEM	CAUSE	SOLUTION
Rotor not turning.	Jamming (due to the presence of a foreign body).	Turn the rotor in the reverse direction to clear jammed material. Check and clean the rotor and teeth according to the Service Schedule.
	Lack of lubrication.	Lubricate according to the Service Schedule.
	Belt breakage or wear.	Replace the belt.
	Broken hydraulic motor bearing or drive shaft.	Check the hydraulic motor drive shaft and if necessary, have it repaired or replaced. Contact your dealer or Blue Diamond® Product Support.
	Oil leak.	Identify and repair all leaks in the hydraulic circuit.
	Skid steer pump in bad condition.	Contact your dealer or Blue Diamond® Product Support.
	Mulcher hydraulic motor malfunctioning.	
Broken teeth and hardware.	Stones or other elements (metals, foreign bodies, etc.).	Avoid these materials.
	Low rotor RPM or low machine power.	Contact your dealer or Blue Diamond® Product Support.
Premature belt wear.	Rotation rate too low.	Adjust the rotation speed according to the operating instructions.
	Starting the mulcher with the rotor touching the terrain.	Lift the machine slightly before starting the rotor. Replace the belt.
	Rotor does not start and belt slips.	Check that the rotor is not jammed.
	Slack belt.	Tighten the belt. Contact your dealer or Blue Diamond® Product Support.
Motor leaking.	Loose Connections.	Check to make sure all hydraulic fittings and hardware are tight.
	Possible Motor Failure.	Contact your dealer or Blue Diamond® Product Support.
Hydraulic oil in the overhung load adapter.	Damaged motor shaft seal.	Check the condition of the motor shaft seal, and replace if required. Contact your dealer or Blue Diamond® Product Support.
High-pitched noise during operation, with the machine working harder when overloaded.	Slack belt.	Tighten the belt. Contact your dealer or Blue Diamond® Product Support.

5. Parts

5.1 Main Components

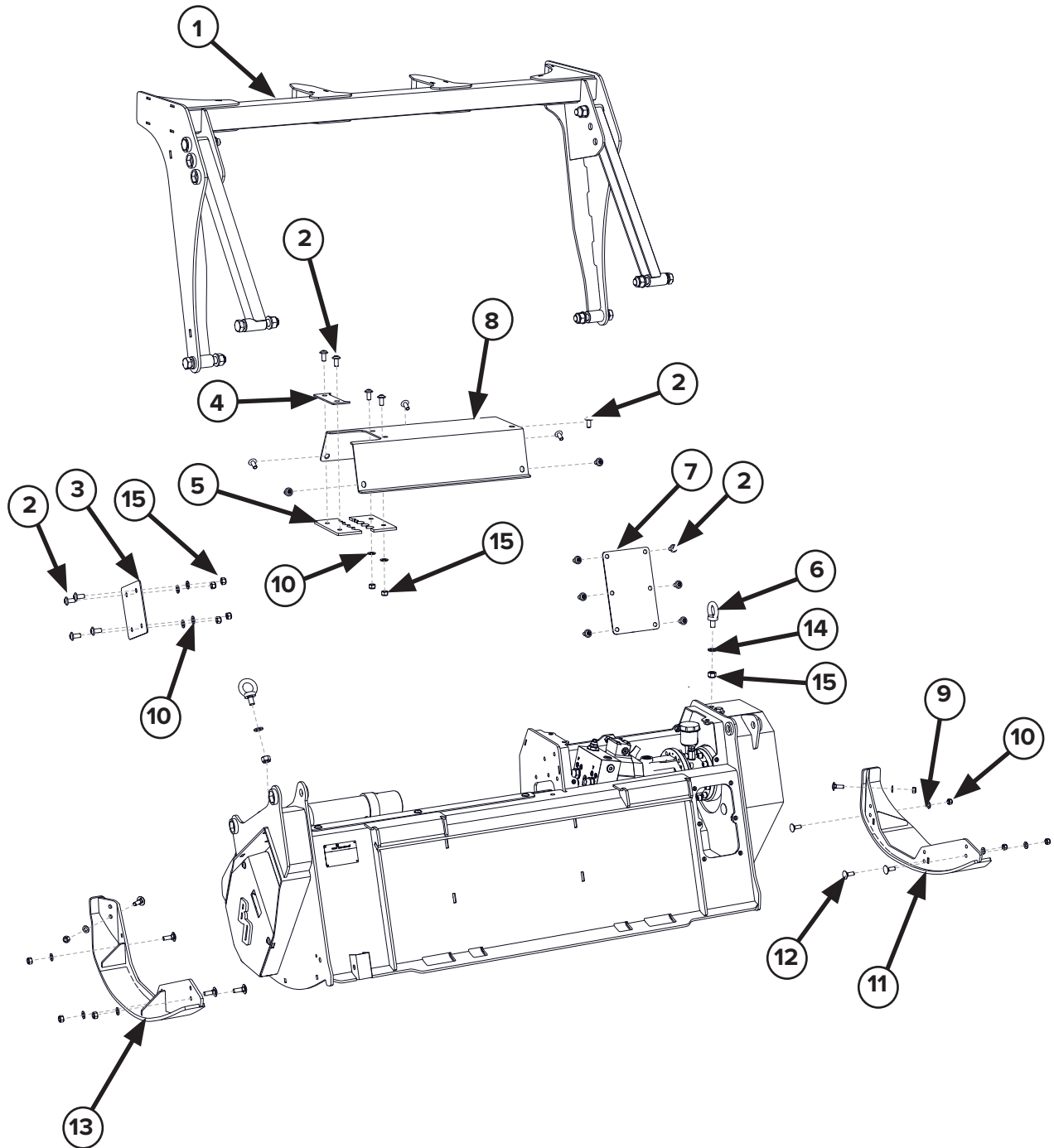

5. Parts

5.1 Main Components Cont'd

ITEM	PART NUMBER	DESCRIPTION	QTY
1	—	PUSH BAR ASSEMBLY (SEE PAGE 39)	1
2	290643	M12 X 1.75MM X 25MM BOLT FLANGED BUTTON HEAD	20
3	—	CYLINDER HOSE OUTLET COVER (5-LINE)	1
4	—	UPPER HOSE OUTLET COVER	1
5	—	HOSE OUTLET RUBBER FLAP	2
6	290576	M16 X 2MM X 27MM SHANK EYEBOLT FULL THREAD	2
7	—	REAR ACCESS COVER	1
8	—	MOTOR COVER	1
9	—	2.3MM X M12 X 24MM FLAT WASHER	16
10	—	M12 X 1.75MM NYLOCK NUT	16
11	290413	RIGHT SKID SHOE	1
12	299069	M12 X 1.75MM X 35MM CARRIAGE BOLT FULL THREAD	8
13	290414	LEFT SKID SHOE	1
14	—	2.7MM X M16 X 30MM FLAT WASHER	2
15	—	M16 X 2.00 NYLOCK NUT	2

5. Parts

5.2 Main Components 2 - Cont'd

ITEM	PART NUMBER	DESCRIPTION	QTY
1	—	FOOT WELDMENT	1
2	—	PIN FOR FOOT WELDMENT	1
3	299143	M12 X 1.75MM X 80MM CARRIAGE BOLT FULL THREAD	15
4	—	4MM R-CLIP COTTER PIN	1
5	299062	2.3MM X M12 X 24MM FLAT WASHER	30
6	299066	M12 X 1.75MM NYLOCK NUT	30
7	290519	LARGE COUNTERBLADE – 300MM	10
8	—	COUNTERBLADE PLATE	1
9	299012	2.7MM X M16 X 30MM FLAT WASHER	15
10	—	M16 X 2MM X 40MM CARRIAGE BOLT FULL THREAD	10
11	—	ADJUSTABLE INTAKE PLATE	1
12	—	M16 X 2.00MM NYLOCK NUT	10
13	290405	CHAIN 10 DIN 5685 11 LINKS L=460 MM	44
14	—	CHAIN ROD	1
15	—	M12 X 1.75MM X 30MM HEX BOLT FULL THREAD	1
16	299069	M12 X 1.75MM X 35MM CARRIAGE BOLT FULL THREAD	15
17	—	FOOT CAP	1

5. Parts

5.3 Main Components 3

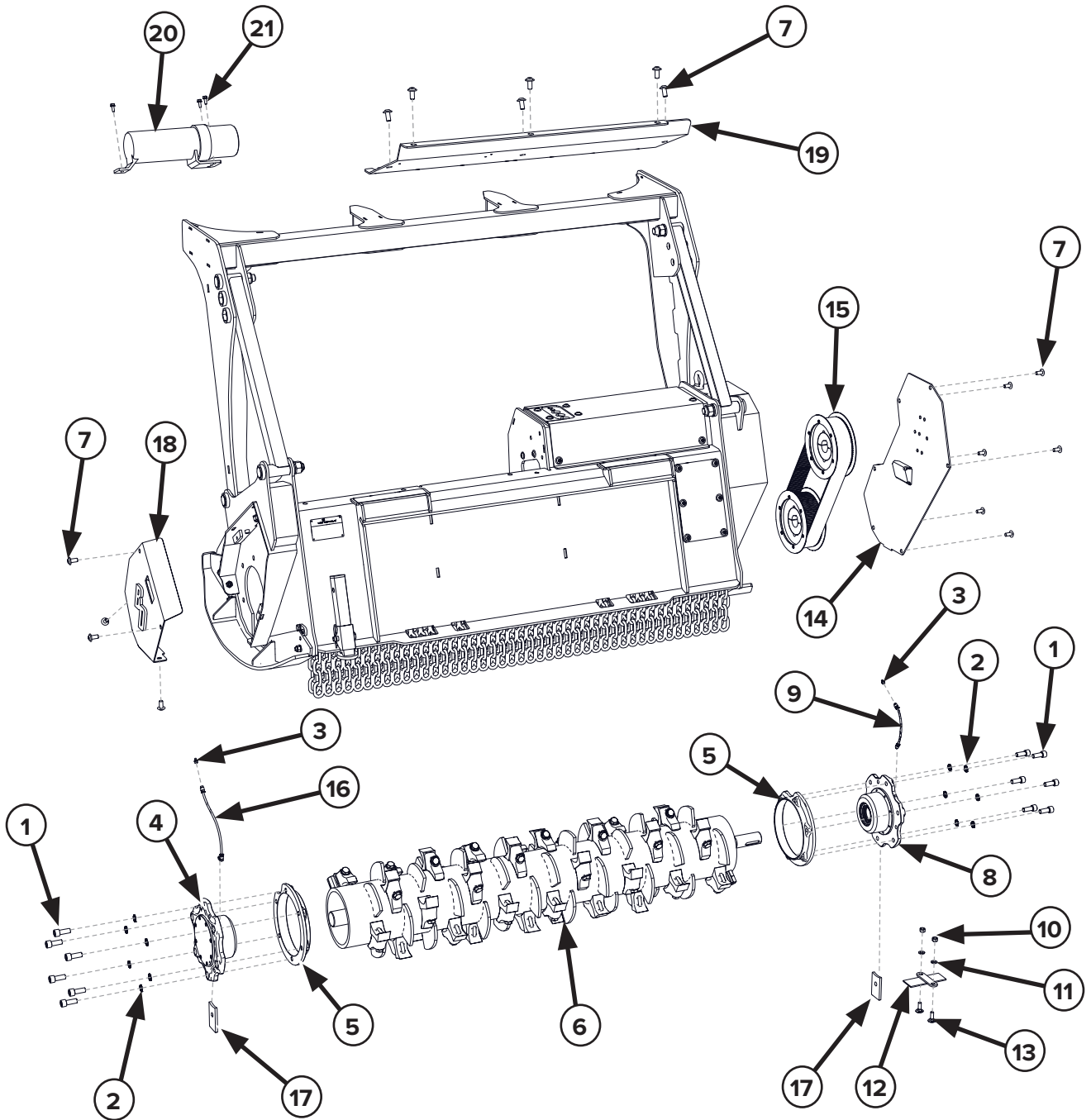

5. Parts

5.3 Main Components 3 - Cont'd

ITEM	PART NUMBER	DESCRIPTION	QTY
1	—	M16 X 2.00MM X 40MM BOLT SOCKET HEAD FULL THREAD	12
2	299090	M16 GROOVED WASHER	12
3	290428	M10 X 1.0 GREASE ZERK STRAIGHT	2
4	290429	NON-DRIVE SIDE ROTOR BEARING ASSEMBLY (SEE PAGE 46)	1
5	290461	ROTOR OUTER WASHER	2
6	290791	ROTOR ASSY (SEE PAGE 48)	1
7	290643	M12 X 1.75MM X 25MM BOLT FLANGED BUTTON HEAD	16
8	290433	DRIVE SIDE ROTOR BEARING ASSEMBLY (SEE PAGE 45)	1
9	—	DRIVE SIDE ROTOR BEARING GREASE LINE	1
10	299066	M12 X 1.75 NYLOCK NUT	4
11	299062	2.3MM X M12 X 24MM WASHER	8
12	290793	ROTOR SHAFT OUTLET COVER	1
13	299069	M12 X 1.75MM X 35MM BOLT HEX HEAD FULL THREAD	2
14	—	BELT DRIVE COVER PLATE	1
15	290794	POLYCHAIN BELT DRIVE ASSEMBLY (SEE PAGE 43)	1
16	—	NON-DRIVE SIDE ROTOR BEARING GREASE LINE	1
17	—	ROTOR SIDE PLATE	2
18	—	NON-DRIVE SIDE COVER	1
19	290599	TOP ACCESS PANEL	1
20	290713	MANUAL TUBE	1
21	—	BOLT FOR MANUAL TUBE	3

5. Parts

5.4 Main Components 4

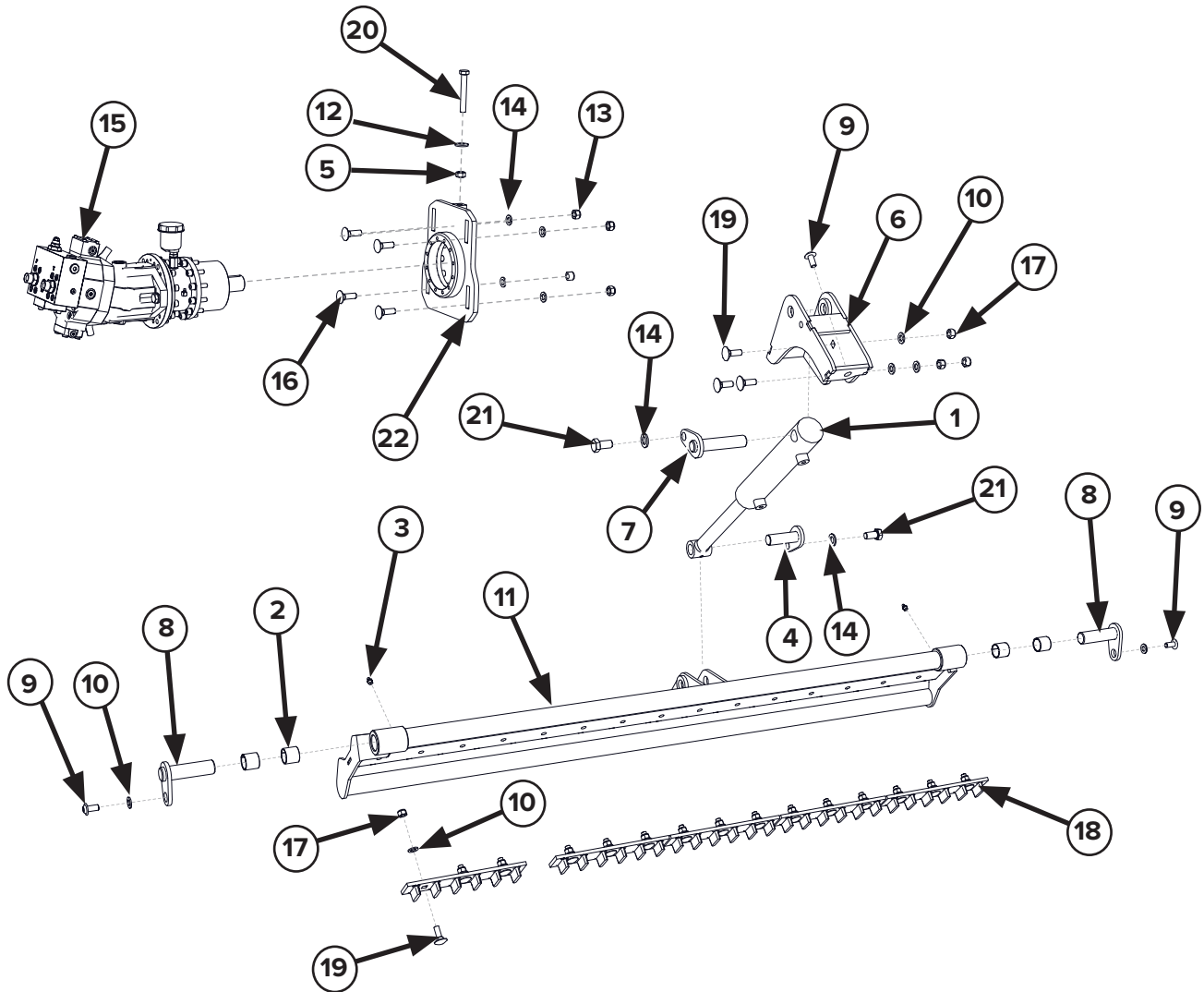

GATE CONTROL OPTION	PART NUMBER	DESCRIPTION
5-LINE	290020	CYLINDER HOSE SET WITH COUPLERS
3-LINE	290021	CYLINDER HOSE SET TO SOLENOID DIVERTER VALVE
	290402	SOLENOID DIVERTER VALVE
	290023	SOLENOID WIRE HARNESS
	290683	FLAT 4-PIN TO DELPHI CONNECTION
	SEE PAGE 51	MACHINE SIDE CONTROL HARNESS

5. Parts

5.4 Main Components 4 - Cont'd

ITEM	PART NUMBER	DESCRIPTION	QTY
1	290736	30MM BORE x 50MM ROD x 200MM STROKE DOUBLE ACTING HYDRAULIC CYLINDER	1
2	—	DISCHARGE COVER PIN BUSHING	4
3	290428	M10 GREASE ZERK STRAIGHT FITTING	2
4	—	CYLINDER PIN - ROD END	1
5	—	M16 X 2.0MM HEX NUT	1
6	—	HYDRAULIC COVER CYLINDER SUPPORT	1
7	—	CYLINDER PIN - BODY END	1
8	—	DISCHARGE COVER HINGE PIN	2
9	290643	M12 X 1.75MM X 25MM BOLT FLANGED BUTTON HEAD	3
10	299062	2.3MM X M12 X 24MM FLAT WASHER	20
11	—	DISCHARGE COVER	1
12	—	4.0MM X M16 X 39MM BELLEVILLE WASHER	1
13	—	M16 X 2.0MM NYLOCK NUT	4
14	299012	2.7MM X M16 X 30MM FLAT WASHER	6
15	—	85CC MOTOR AND LOAD ADAPTER ASSEMBLY - 5-LINE (SEE PAGE 40)	1
	—	85CC MOTOR AND LOAD ADAPTER ASSEMBLY - 3-LINE (SEE PAGE 41)	
16	—	M16 X 2MM X 50MM CARRIAGE BOLT FULL THREAD	4
17	299066	M12 X 1.75MM NYLOCK NUT	18
18	290519	LARGE COUNTERBLADE - 300MM	5
19	299069	M12 X 1.75MM X 35MM CARRIAGE BOLT FULL THREAD	18
20	—	M16 X 2.00MM X 140MM BOLT HEX HEAD PARTIAL THREAD	1
21	—	M16 X 2MM X 30MM HEX BOLT FULLY THREADED	2
22	—	TENSIONER PLATE ASSEMBLY (SEE PAGE 44)	1

5. Parts

5.5 Main Frame

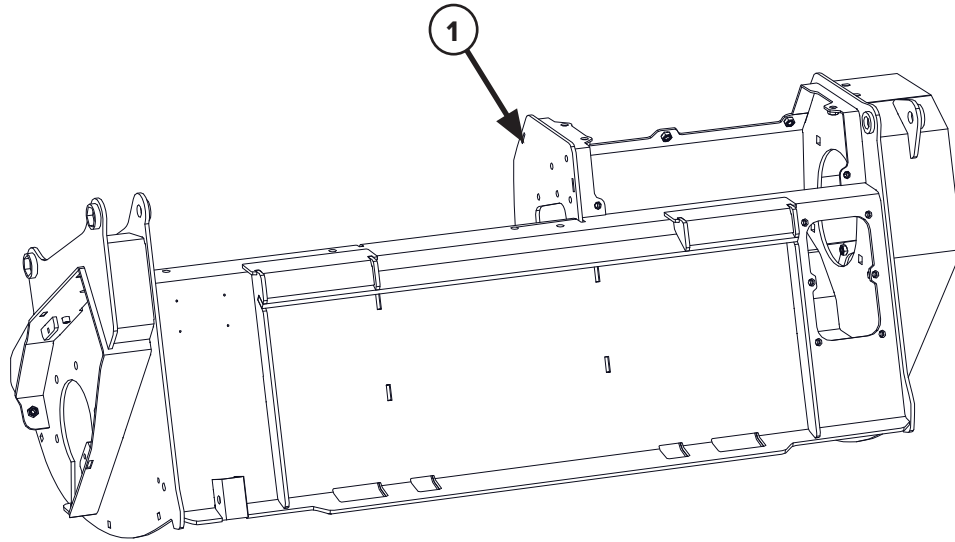

ITEM	PART NUMBER	DESCRIPTION	QTY
1	290790	MAIN FRAME	1

5. Parts

5.6 Push Bar Assembly

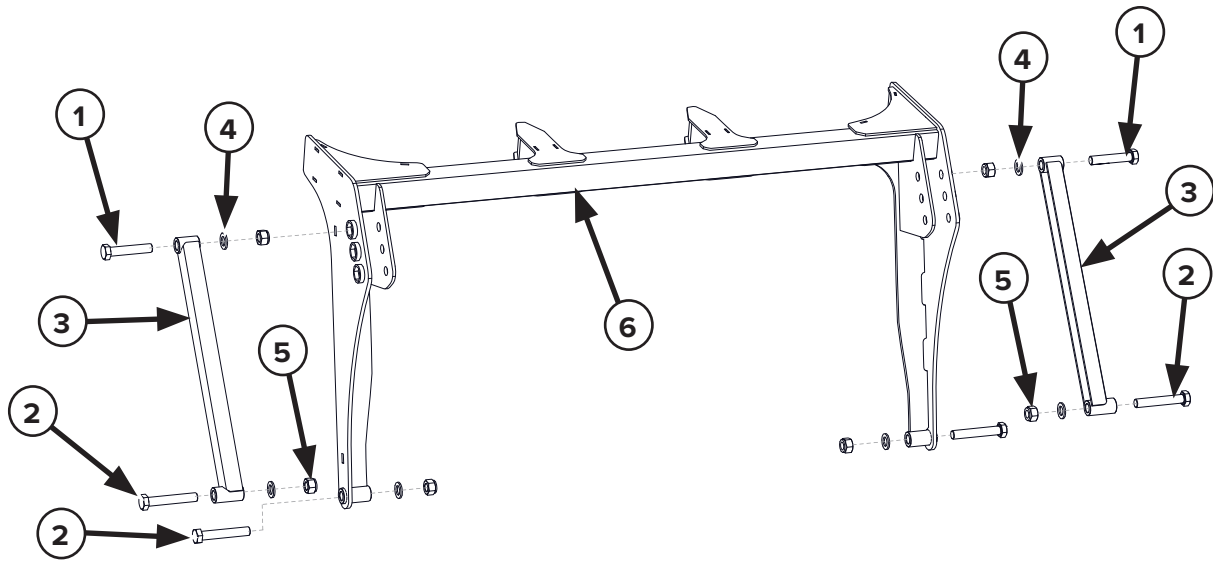

ITEM	PART NUMBER	DESCRIPTION	QTY
1	—	BOLT FOR TOP OF ADJUSTMENT BAR	2
2	—	BOLT FOR BOTTOM OF ADJUSTMENT BAR	4
3	—	ADJUSTMENT BAR	2
4	—	3.7MM X M24 X 44MM FLAT WASHER	2
5	—	NUT FOR ADJUSTMENT BAR	6
6	—	PUSH BAR WELDMENT	1

5. Parts

5.7 5-Line Motor and Load Adapter Assembly

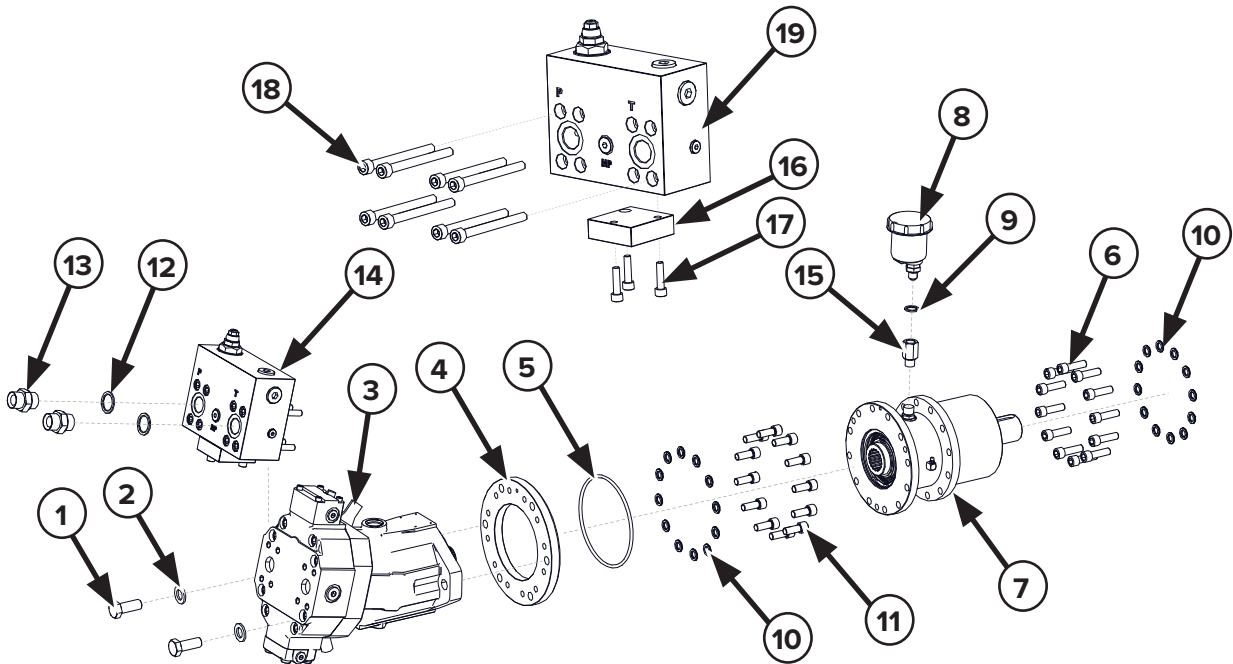

ITEM	PART NUMBER	DESCRIPTION	QTY
1	—	M16 X 2MM X 40MM BOLT HEX HEAD FULL THREAD	2
2	—	2.7MM X M16 X 30MM FLAT WASHER	2
3	290629	HYDRAULIC PISTON MOTOR BOSCH REXROTH 85 CC	1
4	290439	MOTOR ADAPTER FLANGE	1
5	290441	2.55" ID X 2.756" OD X 0.103" DIA. O-RING	1
6	—	M12 X 1.75MM X 40MM BOLT SOCKET HEAD FULL THREAD	12
7	290442	OVERHUNG LOAD ADAPTER (SEE PAGE 42)	1
8	—	OIL EXPANSION TANK	1
9	—	WASHER	1
10	—	2.3MM X M12 X 24MM FLAT WASHER	24
11	—	M12 X 1.75MM X 30MM BOLT SOCKET HEAD FULL THREAD	12
12	—	WASHER	2
13	—	FITTING	2
14	—	5-LINE HYDRAULIC BLOCK ASSEMBLY (PARTS 16-19)	1
15	—	ADAPTER	1
16	290482	SOLENOID END COVER	1
17	—	SOLENOID END COVER BOLT SHORT	3
18	—	HYDRAULIC BLOCK BOLT LONG	8
19	—	HYDRAULIC BLOCK	1

5. Parts

5.8 3-Line Motor and Load Adapter Assembly

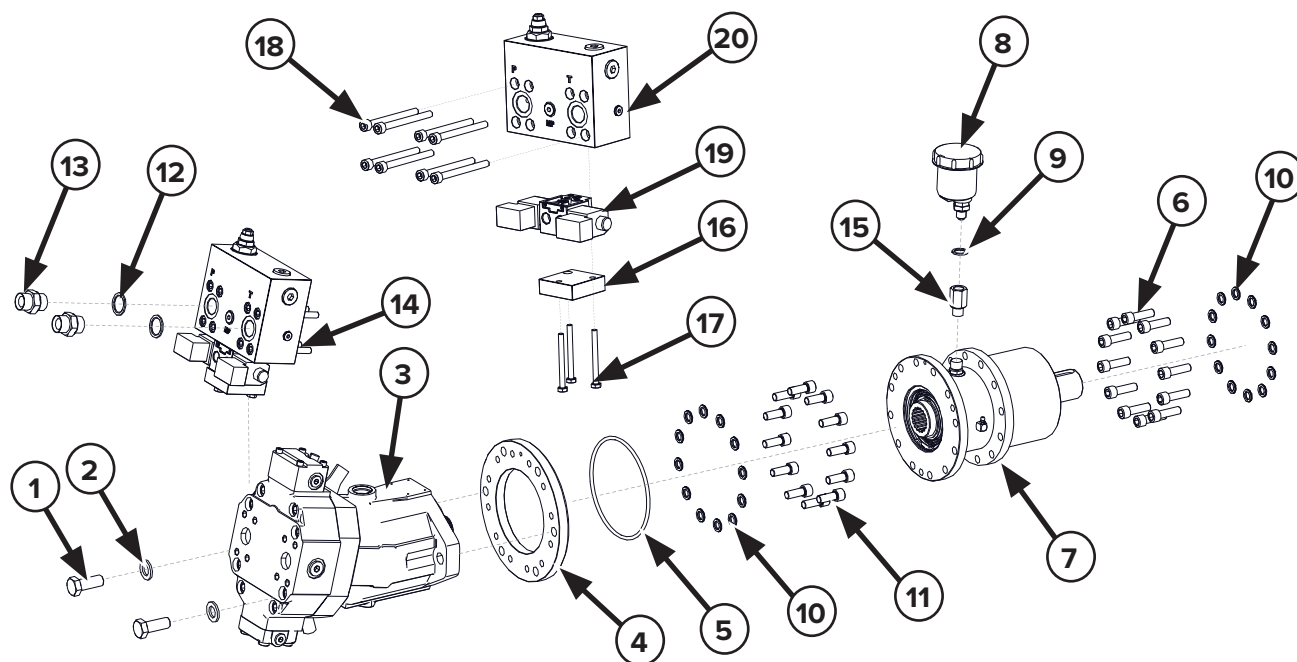

ITEM	PART NUMBER	DESCRIPTION	QTY
1	—	M16 X 2MM X 40MM BOLT HEX HEAD FULL THREAD	2
2	299012	2.7MM X M16 X 30MM FLAT WASHER	2
3	290629	HYDRAULIC PISTON MOTOR BOSCH REXROTH 85 CC	1
4	290439	MOTOR ADAPTER FLANGE	1
5	290441	2.55" ID X 2.75" OD X 0.103" DIA. O-RING	1
6	—	M12 X 1.75MM X 40MM BOLT SOCKET HEAD FULL THREAD	12
7	290442	OVERHUNG LOAD ADAPTER (SEE PAGE 42)	1
8	—	OIL EXPANSION TANK	1
9	—	WASHER	1
10	—	2.3MM X M12 X 24MM FLAT WASHER	24
11	—	M12 X 1.75MM X 30MM BOLT SOCKET HEAD FULL THREAD	12
12	—	WASHER	2
13	—	FITTING	2
14	—	3-LINE HYDRAULIC BLOCK ASSEMBLY (PARTS 16-20)	1
15	—	ADAPTER	1
16	290482	SOLENOID END COVER	1
17	—	SOLENOID END COVER BOLT	3
18	—	HYDRAULIC BLOCK BOLT	8
19	290402	SOLENOID DIVERTER VALVE	1
20	—	HYDRAULIC BLOCK	1

5. Parts

5.9 Overhung Load Adapter — 290442

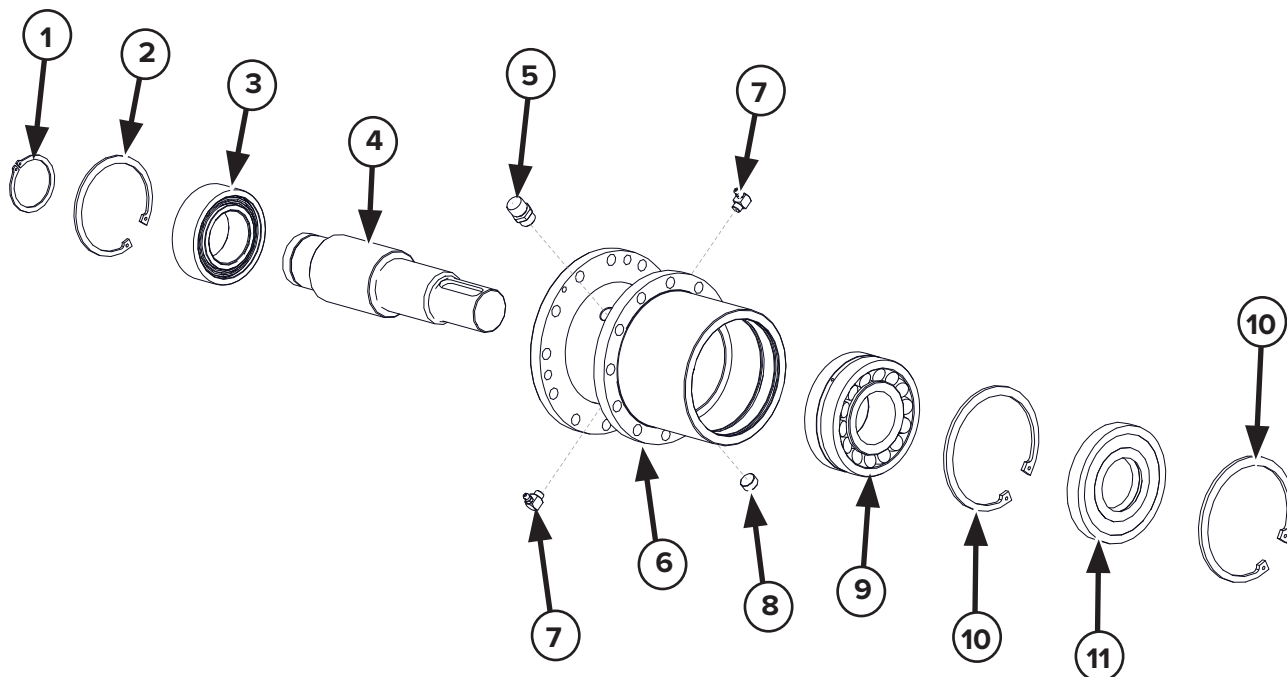

ITEM	PART NUMBER	DESCRIPTION	QTY
1	290446	55MM ID X 2.15MM THICK RETAINING RING EXTERNAL	1
2	290447	100MM ID X 3MM THICK RETAINING RING INTERNAL	1
3	290633	50MM SHAFT DIA. ANGULAR CONTACT BALL BEARING	1
4	290448	SPINDLE	1
5	290586	OIL PLUG FOR GEARBOX B. 3/8"	1
6	290449	HOUSING	1
7	290451	M10 90° GREASE ZERK	2
8	290637	3/8" MALE PLUG	1
9	290634	50MM SHAFT X 110MM HOUSING ID X 40MM WIDE SPHERICAL ROLLER BEARING	1
10	290562	120MM ID X 4MM THICK RETAINING RING	2
11	290453	55MM ID X 120MM OD X 16MM THICK SEAL	1

5. Parts

5.10 Belt Drive — 290438

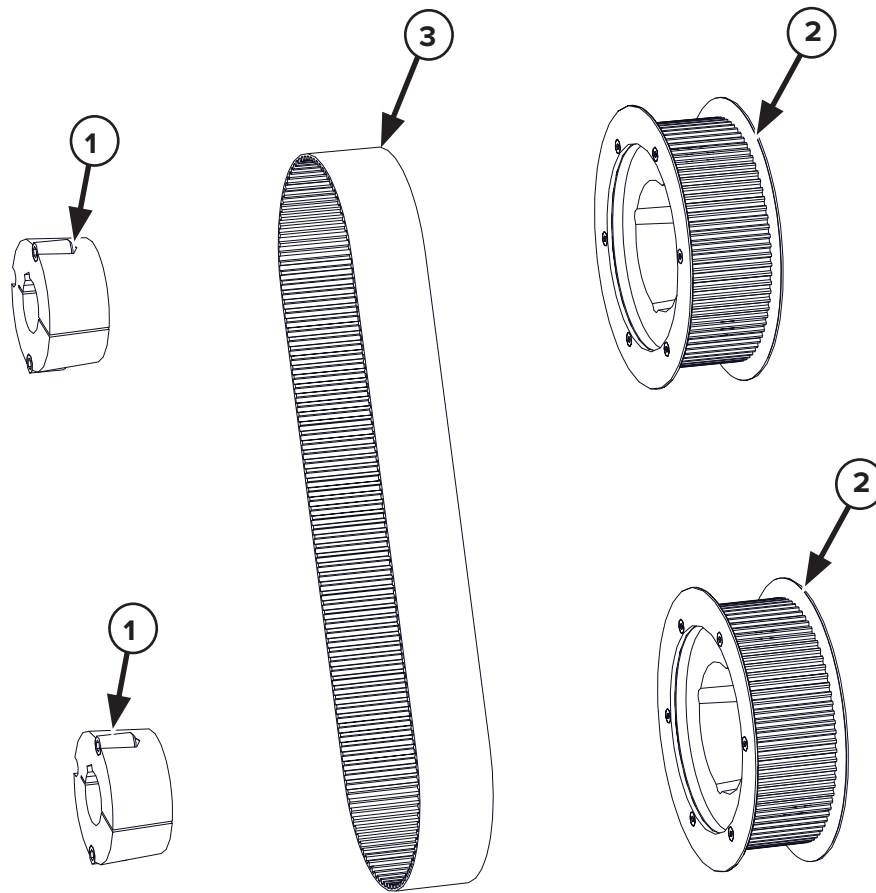

ITEM	PART NUMBER	DESCRIPTION	QTY
1	290627	TAPERLOCK FOR KEY 3020 SHAFT 45MM	1
2	290624	BELT PULLEY - 80 TOOTH	2
3	290623	SYNCHRO BELT POLYCHAIN GTC-GTV 1440MM OD X 8MM PITCH X 62MM WIDE	1

5. Parts

5.11 Tensioner Plate Assembly

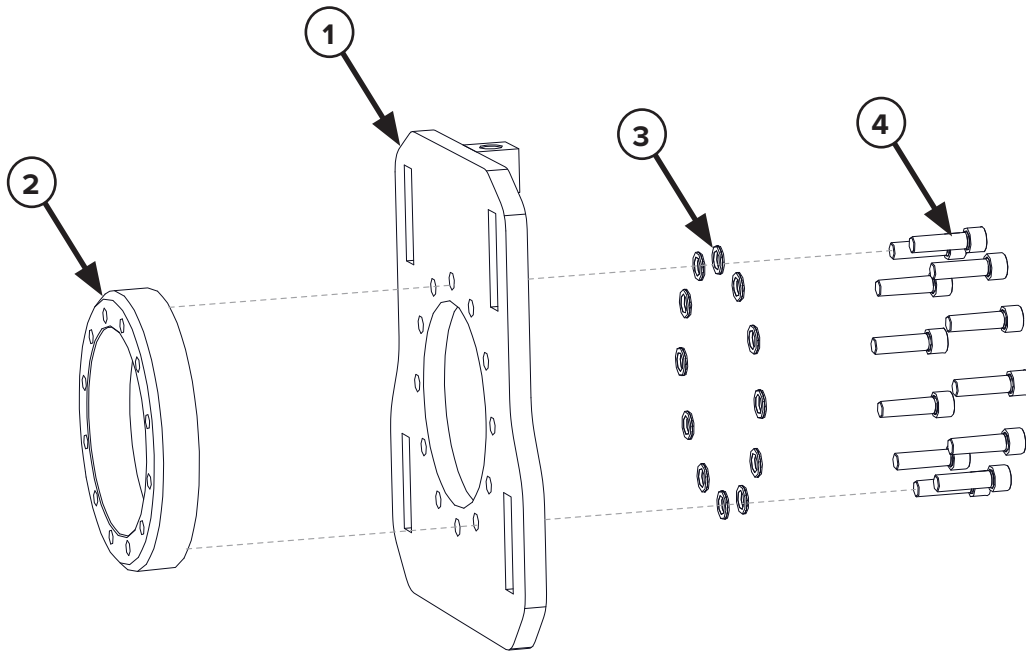

ITEM	PART NUMBER	DESCRIPTION	QTY
1	—	TENSIONER PLATE	1
2	290443	SEPARATOR FLANGE	1
3	—	2.3MM X M12 X 24MM FLAT WASHER	12
4	—	M12 X 1.75MM X 40MM BOLT SOCKET HEAD FULLY THREADED	12

5. Parts

5.12 Drive Side Rotor Bearing Assembly – 290433

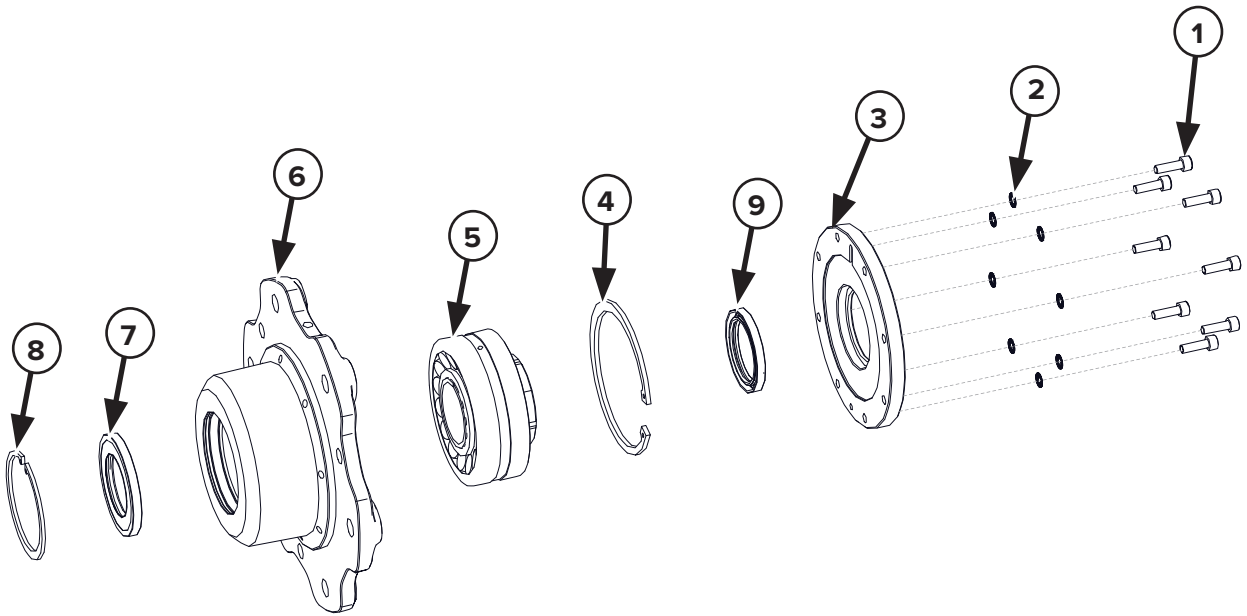

ITEM	PART NUMBER	DESCRIPTION	QTY
1	—	M8 X 1.25MM X 25MM BOLT HEX HEAD FULL THREAD	8
2	—	M8 GROOVED WASHER	8
3	290511	DRIVE SIDE ROTOR BEARING SUPPORT COVER	1
4	290454	130MM ID X 4MM THICK RETAINING RING INTERNAL	1
5	290456	65MM SHAFT X 140MM HOUSING ID X 48MM WIDE ROLLER BEARING + SLEEVE H2312	1
6	290457	BEARING HOUSING	1
7	290458	55MM ID X 90MM OD X 8MM THICK SEAL	1
8	290573	90MM ID X 3MM THICK RETAINING RING INTERNAL	1
9	290463	55MM ID X 75MM OD X 8MM THICK SEAL	1

5. Parts

5.13 Non-Drive Side Rotor Bearing Assembly – 290429

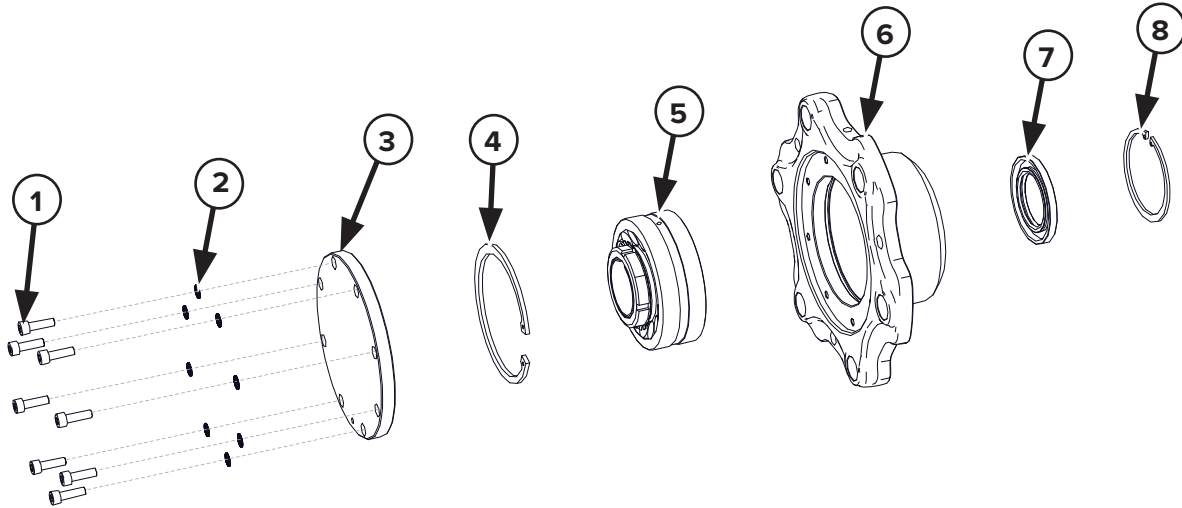

ITEM	PART NUMBER	DESCRIPTION	QTY
1	—	M8 X 1.25MM X 25MM BOLT SOCKET HEAD FULL THREAD	8
2	—	M8 GROOVED WASHER	8
3	290512	NON-DRIVE SIDE ROTOR BEARING SUPPORT COVER	1
4	290454	130MM ID X 4MM THICK RETAINING RING INTERNAL	1
5	290456	65MM SHAFT X 140MM HOUSING ID X 48MM WIDE ROLLER BEARING + SLEEVE H2312	1
6	290457	BEARING HOUSING	1
7	290458	55MM ID X 90MM OD X 8MM THICK SEAL	1
8	290573	90MM ID X 3MM THICK RETAINING RING INTERNAL	1

5. Parts

5.14 Rotor Bearing – 290456

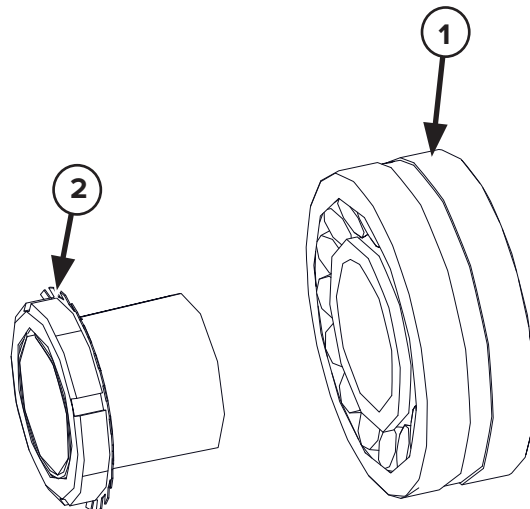

ITEM	PART NUMBER	DESCRIPTION	QTY
1	290636	65MM SHAFT X 140MM HOUSING ID X 48MM WIDE SPHERICAL ROLLER BEARING	1
2	290459	TAPERED SLEEVE H2312	1

5. Parts

5.15 Rotor

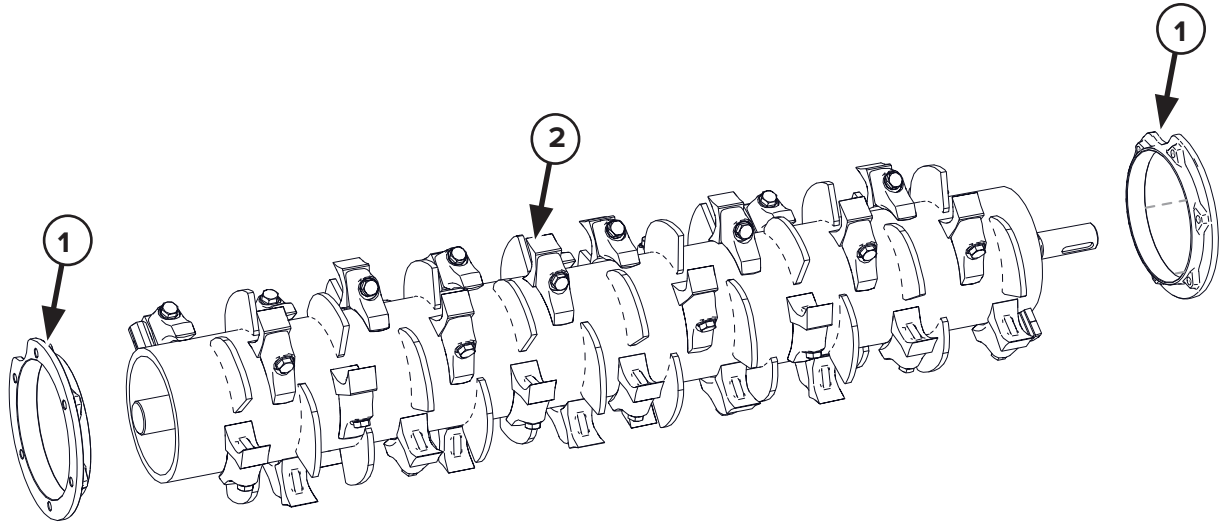

ITEM	PART NUMBER	DESCRIPTION	QTY
1	290461	ROTOR OUTER WASHER	2
2	290791	ROTOR ASSEMBLY WITH CHIPPING TEETH (SEE PAGE 49)	1

5. Parts

5.16 Rotor Assembly Parts

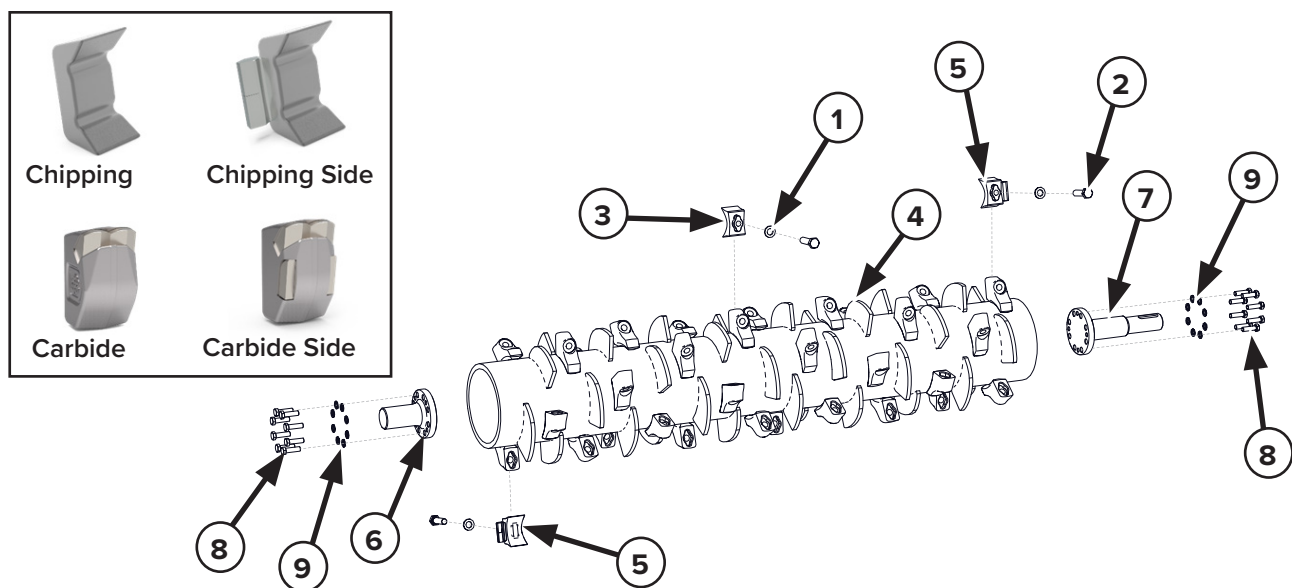

ITEM	PART NUMBER	DESCRIPTION	QTY
1	299012	2.7MM X M16 X 30MM FLAT WASHER	38
2	299091	M16 X 1.50 X 60MM BOLT HEX HEAD	38
3	290500	CHIPPING TOOTH	36
	290502	CARBIDE TOOTH	
4	290790	ROTOR WELDMENT WITH DEPTH LIMITERS	1
5	290501	CHIPPING SIDE TOOTH	2
	290503	CARBIDE SIDE TOOTH	
6	290499	ROTOR SHAFT NON DRIVE SIDE	1
7	290734	ROTOR SHAFT DRIVE SIDE	1
8	—	M8 X 1.25MM X 25MM BOLT HEX HEAD FULL THREAD	16
9	—	2.3MM X M12 X 24MM FLAT WASHER	16

TOOTH KIT	DESCRIPTION
290508-KIT-60	CHIPPING TEETH
290509-KIT-60	CARBIDE TEETH

5. Parts

5.17 Hydraulic Hoses

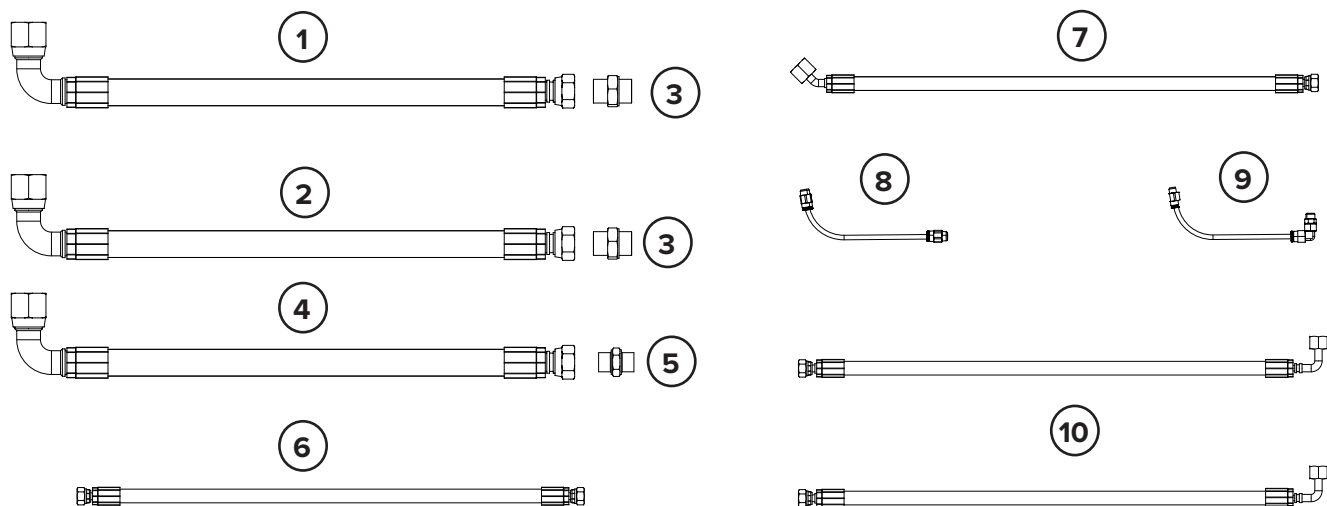

ITEM	PART NUMBER	DESCRIPTION	QTY
1	—	PRESSURE HOSE - 4SC 90° FEMALE #12 JIC TO STRAIGHT FEMALE #12 JIC 94.5" LONG	1
2	—	RETURN HOSE - 2SC 90° FEMALE #12 JIC TO STRAIGHT FEMALE #12 JIC 94.5" LONG	1
3	295010-M12JIC-M12BSPPES	STRAIGHT FITTING MALE #12 JIC TO MALE #12 BSPP ENCAPSULATED SEAL	2
4	—	CASE DRAIN HOSE - R2 90° FEMALE #12 JIC TO STRAIGHT FEMALE #12 JIC 94.5" LONG	1
5	—	STRAIGHT FITTING MALE #12 JIC TO MALE #8 BSPP ENCAPSULATED SEAL	1
6	—	5-LINE CYLINDER EXTEND HOSE - 2SC STRAIGHT FEMALE #6 JIC TO STRAIGHT FEMALE #6 JIC 80.7" LONG	1
7	—	5-LINE CYLINDER RETRACT HOSE - 2SC 45° FEMALE #6 JIC TO STRAIGHT FEMALE #6 JIC 80.7" LONG	1
8	—	DRIVE SIDE ROTOR BEARING GREASE HOSE - STRAIGHT MALE 1/8" NPT TO STRAIGHT MALE 1/8" NPT 5.9" LONG	1
9	—	NON DRIVE SIDE ROTOR BEARING GREASE HOSE - 90° MALE 1/8" NPT TO STRAIGHT MALE 1/8" NPT 9.5" LONG	1
10	—	3-LINE CYLINDER HOSE - 2SC 90° FEMALE #6 JIC TO STRAIGHT FEMALE #6 JIC 23.6" LONG	2
NS	295030-M12JIC-M12ORB	MOTOR CASE DRAIN FITTING 90 DEGREE MALE #12 JIC X MALE #12 ORING BOSS	1
NS	224068	CASE DRAIN COUPLER FEMALE FLAT FACE STRAIGHT 3/8" BODY FEMALE #8 BSPP	1
NS	224013	COUPLER FEMALE FLAT FACE STRAIGHT 1/2" BODY FEMALE #12 BSPP	1
	224026	COUPLER FEMALE FLAT FACE STRAIGHT 3/4" BODY FEMALE #12 BSPP	1
NS	224014	COUPLER MALE FLAT FACE STRAIGHT 1/2" BODY FEMALE #12 BSPP	1
	224027	COUPLER MALE FLAT FACE STRAIGHT 3/4" BODY FEMALE #12 BSPP	1

5. Parts

5.18 3-Line Electrical Wire Harness Options

MACHINE CONTROL HARNESS:

Use one of the below harnesses with the 290683 adapter harness to connect to the attachment side harness.

PART NUMBER	DESCRIPTION
216934	UNIVERSAL 14-PIN
216931	CAT 8-PIN
160416 + 216934	BOBCAT 7-PIN
290680	UNIVERSAL CONTROL BOX KIT (290683 INCLUDED)
216936	JOHN DEERE® 14-PIN

PIN CONTROLS (DELPHI CONNECTOR)

PIN	FUNCTION
D	CLOSE DISCHARGE COVER
E	OPEN DISCHARGE COVER
F	GROUND

OPTIONAL EXTENSIONS:

PART NUMBER	DESCRIPTION
290684	5 FT CONTROL LEG EXTENSION
216921	10 FT CONTROL LEG EXTENSION
200013	10 FT POWER LEG EXTENSION

5. Parts

5.19 3-Line Universal Wire Harness Kit - 290680

Control Box Segment - 290681

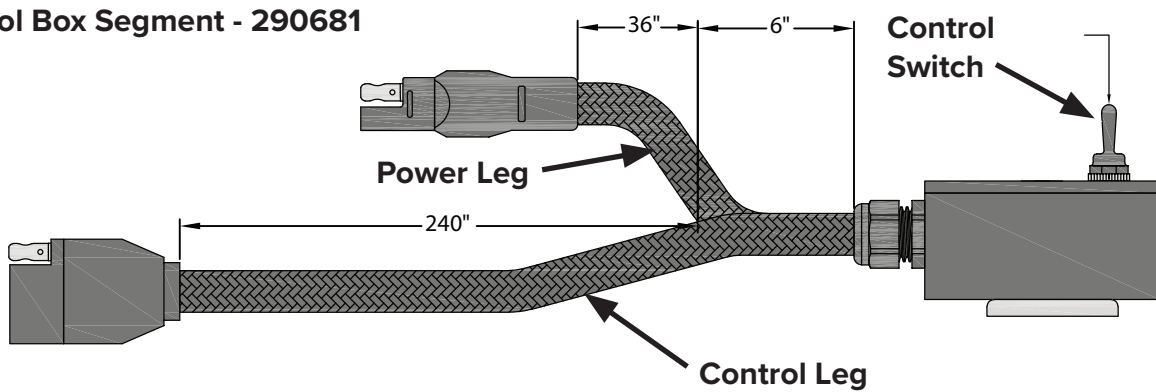

Delphi Adapter Segment - 290683

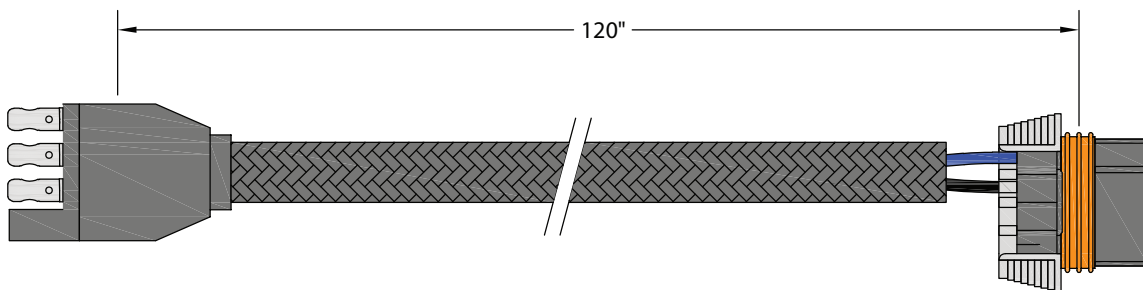

12V Plug Segment - 200021

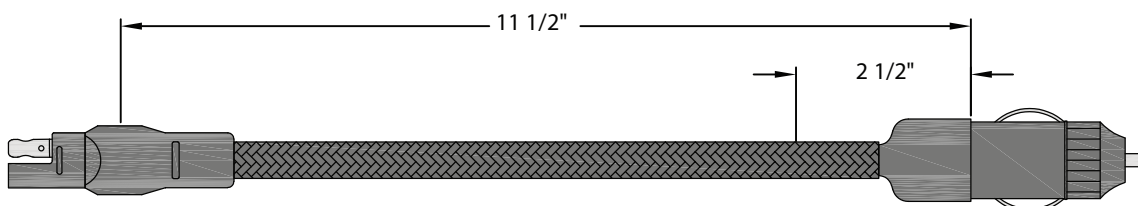

Battery Terminal Segment - 290682

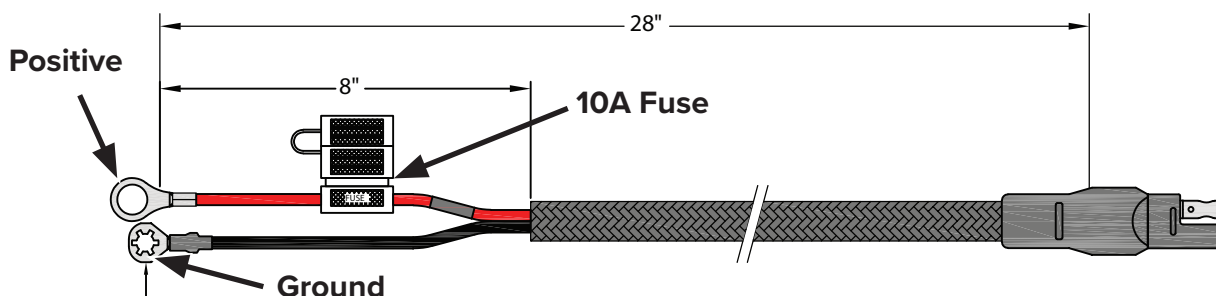

5. Parts

5.20 Decals



5. Parts

5.20 Decals Cont'd

- 1 
- 2 
- 3 
- 4 
- 5 
- 6 
- 7 
- 8 
- 9 

ITEM	PART NUMBER	DESCRIPTION	QTY
1	BD-081	3.0" x 12.0" Decal, Warning Keep Hands and Feet Away	1
2	BD-055	3.0" x 11.9" Decal, Danger Debris Discharge Area	1
3	BD-060	2.4375" x 3.375" Decal, Blue Diamond Attachments Diamond Shape	2
4	BD-112	12.18" x 9.47" Decal, Blue Diamond Attachments Diamond Shape	1
5	BD-092	1.5" x 2.0" Decal, Warranty Registration QR	1
6	BD-123	3.0" x 3.0" Decal, High Pressure Fluid Hazard	1
7	BD-001	3.0" x 3.0" Decal, Read Owner's Manual	1
8	BD-004	2.0" x 4.0" Decal, Grease All Fitting Every 8 Hours	1
9	BD-134	2.0" Tall Decal, Tag Line Single Line	1

6. Specifications

6.1 Attachment Specifications

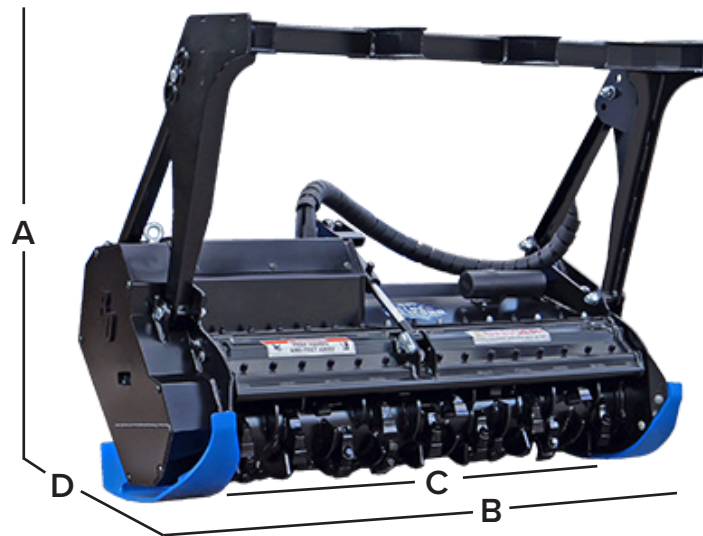

DESCRIPTION	HEAVY DUTY SKID STEER DRUM MULCHER
Overall Height (A)	55"
Overall Width (B)	73"
Working Width (C)	60"
Overall Length (D)	45"
Working Pressure (psi)	180 bar (2600 psi) - 380 bar (5500 psi)
Weight (No Mount) (lbs)	2105
Motor Size	Variable 55 - 85 cc
Recommended Flow (gpm)	26-46
Pulley Ratio	1
Rotor Diameter	15"
Number of Belts	1 Polychain Carbon Fiber Belt
Recommended Rotor RPM (Max)	1800-2500
Counterblades	3
Chain Guard	2 Rows
Maximum Cutting Capacity	7"

In the table below, document the specifications of the skid steer the mulcher is tuned to each time it is tuned for a new machine.

DATE	HOST MACHINE ID	AUXILIARY PRESSURE	AUXILIARY FLOW

6. Specifications

6.2 Torque Specifications

Standard Hardware and Lock Nuts

BOLT TYPE	CLASS 4.8		CLASS 8.8 OR 9.8		CLASS 10.9		CLASS 12.9		
	Size	Lubricated	Dry	Lubricated	Dry	Lubricated	Dry	Lubricated	Dry
M6		4.8 N•m	6 N•m	9 N•m	11 N•m	13 N•m	17 N•m	15 N•m	19 N•m
		3.5 lbf•ft	4.5 lbf•ft	6.5 lbf•ft	8.5 lbf•ft	9.5 lbf•ft	12 lbf•ft	11.5 lbf•ft	14.5 lbf•ft
M8		12 N•m	15 N•m	22 N•m	28 N•m	32 N•m	40 N•m	37 N•m	47 N•m
		8.5 lbf•ft	11 lbf•ft	16 lbf•ft	20 lbf•ft	24 lbf•ft	30 lbf•ft	28 lbf•ft	35 lbf•ft
M10		23 N•m	29 N•m	43 N•m	55 N•m	63 N•m	80 N•m	75 N•m	95 N•m
		17 lbf•ft	21 lbf•ft	32 lbf•ft	40 lbf•ft	47 lbf•ft	60 lbf•ft	55 lbf•ft	70 lbf•ft
M12		40 N•m	50 N•m	75 N•m	95 N•m	110 N•m	140 N•m	130 N•m	165 N•m
		29 lbf•ft	37 lbf•ft	55 lbf•ft	70 lbf•ft	80 lbf•ft	105 lbf•ft	95 lbf•ft	120 lbf•ft
M14		63 N•m	80 N•m	120 N•m	150 N•m	175 N•m	225 N•m	205 N•m	260 N•m
		47 lbf•ft	60 lbf•ft	88 lbf•ft	110 lbf•ft	130 lbf•ft	165 lbf•ft	150 lbf•ft	190 lbf•ft
M16		135 N•m	175 N•m	260 N•m	330 N•m	375 N•m	475 N•m	440 N•m	560 N•m
		100 lbf•ft	125 lbf•ft	195 lbf•ft	250 lbf•ft	275 lbf•ft	350 lbf•ft	325 lbf•ft	410 lbf•ft
M18		135 N•m	175 N•m	260 N•m	330 N•m	375 N•m	475 N•m	440 N•m	560 N•m
		100 lbf•ft	125 lbf•ft	195 lbf•ft	250 lbf•ft	275 lbf•ft	350 lbf•ft	325 lbf•ft	410 lbf•ft
M20		190 N•m	240 N•m	375 N•m	475 N•m	530 N•m	675 N•m	625 N•m	800 N•m
		140 lbf•ft	180 lbf•ft	275 lbf•ft	350 lbf•ft	400 lbf•ft	500 lbf•ft	460 lbf•ft	580 lbf•ft
M22		260 N•m	330 N•m	510 N•m	650 N•m	725 N•m	925 N•m	850 N•m	1075 N•m
		190 lbf•ft	250 lbf•ft	375 lbf•ft	475 lbf•ft	540 lbf•ft	675 lbf•ft	625 lbf•ft	800 lbf•ft
M24		330 N•m	425 N•m	650 N•m	825 N•m	925 N•m	1150 N•m	1075 N•m	1350 N•m
		250 lbf•ft	310 lbf•ft	475 lbf•ft	600 lbf•ft	675 lbf•ft	850 lbf•ft	800 lbf•ft	1000 lbf•ft
M27		490 N•m	625 N•m	950 N•m	1200 N•m	1350 N•m	1700 N•m	1600 N•m	2000 N•m
		360 lbf•ft	450 lbf•ft	700 lbf•ft	875 lbf•ft	1000 lbf•ft	1250 lbf•ft	1150 lbf•ft	1500 lbf•ft
M30		675 N•m	850 N•m	1300 N•m	1650 N•m	1850 N•m	2300 N•m	2150 N•m	2700 N•m
		490 lbf•ft	625 lbf•ft	950 lbf•ft	1200 lbf•ft	1350 lbf•ft	1700 lbf•ft	1600 lbf•ft	2000 lbf•ft
M33		900 N•m	1150 N•m	1750 N•m	2200 N•m	2500 N•m	3150 N•m	2900 N•m	3700 N•m
		675 lbf•ft	850 lbf•ft	1300 lbf•ft	1650 lbf•ft	1850 lbf•ft	2350 lbf•ft	2150 lbf•ft	2750 lbf•ft
M36		1150 N•m	1450 N•m	2250 N•m	2850 N•m	3200 N•m	4050 N•m	3750 N•m	4750 N•m
		850 lbf•ft	1075 lbf•ft	1650 lbf•ft	2100 lbf•ft	2350 lbf•ft	3000 lbf•ft	2750 lbf•ft	3500 lbf•ft

**This page intentionally
left blank**



Warranty

MANUFACTURER'S LIMITED WARRANTY

BLUE DIAMOND® ATTACHMENTS, a manufacturer of quality attachments, warrants new BLUE DIAMOND® ATTACHMENTS products and/or attachments at the time of delivery to the original purchaser, to be free from defects in material and workmanship when properly set up and operated in accordance with the recommendations set forth by BLUE DIAMOND® ATTACHMENTS, LLC.

BLUE DIAMOND® ATTACHMENTS liability for any defect with respect to accepted goods shall be limited to repairing the goods at a BLUE DIAMOND® ATTACHMENTS designated location or at an authorized dealer location, or replacing them, as BLUE DIAMOND® ATTACHMENTS shall elect. The above shall be in accordance with BLUE DIAMOND® ATTACHMENTS warranty adjustment policies. BLUE DIAMOND® ATTACHMENTS obligation shall terminate twelve (12) months for the Heavy Duty Skid Steer Drum Mulcher after the delivery of the goods to original purchaser.

This warranty shall not apply to any machine or attachment which shall have been repaired or altered outside the BLUE DIAMOND® ATTACHMENTS factory or authorized BLUE DIAMOND® ATTACHMENTS dealership or in any way so as in BLUE DIAMOND® ATTACHMENTS judgment, to affect its stability or reliability, nor which has been subject to misuse, negligence or accident beyond the company recommended machine rated capacity.

WARRANTY CLAIM

To submit a warranty claim, a claim must be filed with BLUE DIAMOND® ATTACHMENTS before work is performed. The BLUE DIAMOND® PRODUCT SUPPORT TEAM will advise repairs and applicable parts exchanges. Tampering with the failed part may void the warranty. This warranty does not include freight or delivery charges incurred when returning machinery for servicing. Dealer mileage, service calls, and pickup/delivery charges are the customers' responsibility.

EXCLUSIONS OF WARRANTY

Except as otherwise expressly stated herein, BLUE DIAMOND® ATTACHMENTS makes no representation or warranty of any kind, expressed or implied, AND MAKES NO WARRANTY OF MERCHANTABILITY IN RESPECT TO ITS MACHINERY AND/OR ATTACHMENTS ARE FIT FOR ANY PARTICULAR PURPOSE. BLUE DIAMOND® ATTACHMENTS shall not be liable for incidental or consequential damages for any breach or warranty, including but not limited to inconvenience, rental of replacement equipment, loss of profits or other commercial loss. Upon purchase, the buyer assumes all liability for all personal injury and property resulting from the handling, possession, or use of the goods by the buyer.

No agent, employee, or representative of BLUE DIAMOND® ATTACHMENTS has any authority to bind BLUE DIAMOND® ATTACHMENTS to any affirmation, representation, or warranty concerning its machinery and/or attachments except as specifically set forth herein.

This warranty policy supersedes any previous documents.

NOTE: Blue Diamond® Attachments is a trademark of BLUE DIAMOND® ATTACHMENTS



QUALITY | DEPENDABILITY | INTEGRITY

Blue Diamond® Attachments
4512 Anderson Road, Knoxville, TN 37918
888-376-7027