

Severe Duty Screening Bucket

Operation and Maintenance Manual



145135

Register your
WARRANTY
within 30 days
of purchase



888-376-7027 | BlueDiamondAttachments.com



BD-092

Introduction: Owner Information

Thank you for your decision to purchase a Blue Diamond® Screening Bucket. To ensure maximum performance of your equipment, it is mandatory that you thoroughly study the Operator's Manual and follow the recommendations. Proper operation and maintenance are essential to maximize equipment life and prevent personal injury.

Operate and maintain this equipment in a safe manner and in accordance with all applicable local, state, and federal codes, regulations and/or laws. Follow all on-product labeling and instructions.

Make sure that all personnel have read this Operator's Manual and thoroughly understand safe and correct operating, installation and maintenance procedures.

Blue Diamond® is continually working to improve its products. Blue Diamond® reserves the right to make any improvements or changes as deemed practical and possible without incurring any responsibility or obligation to make any changes or additions to equipment sold previously.

Although great care has been taken to ensure the accuracy of this publication, Blue Diamond® makes no warranty or guarantee of any kind, written or expressed, implied or otherwise with regard to the information contained within this manual. Blue Diamond® assumes no responsibility for any errors that may appear in this manual and shall not be liable under any circumstances for incidental, consequential or punitive damages in connection with, or arising from the use of this manual.

Keep this manual available for frequent reference. All new operators or owners must review the manual before using the equipment and annually thereafter. Contact your Blue Diamond® Attachments Dealer for assistance, information, or additional copies of the manual. Contact www.bluediamondattachments.com or call 888-376-7027 for a complete list of dealers in your area.

Serial Number Location:

Please record attachment information in the space provided for future reference.



Model Number: _____

Serial Number: _____

Dealer Name: _____

Dealer Number: _____

Date of Purchase: _____

The serial number plate is located on the top right side of the bucket when looking at the bucket with the stars closest to you as shown above.

Always use your serial number when requesting information or when ordering parts.

NOTE: The directions left, right, front, and rear, as mentioned throughout this manual, are as viewed from the operator's position.

Table of Contents

Introduction: Owner Information	2	Warranty	47
1. Introduction	4		
1.1 Attachment Identification	4		
1.2 About this Attachment	5		
1.3 Attachment Model Numbers	5		
2. Safety	6		
2.1 General Safety Information	6		
2.2 Operators	7		
2.3 Safety Guidelines	8		
3. Operation	10		
3.1 Pre-Operation Inspection	10		
3.2 Entering and Exiting the Prime Mover	10		
3.3 Attachment Installation with Excavator	11		
3.4 Operating the Attachment	12		
4. Maintenance	14		
4.1 Service Schedule	14		
4.2 Maintenance Safety	15		
4.3 Daily Maintenance	16		
4.4 Monthly Maintenance	16		
4.5 Flexi-Star Replacement	16		
4.6 Comb Kits & Stripper Plates (Optional)	17		
4.7 Storage	17		
4.8 Troubleshooting	18		
5. Hydraulic Circuit Patterns	20		
5.1 Hydraulic Circuit Pattern for All Models	20		
6. Drill Patterns	21		
6.1 Drill Pattern for All Models	21		
7. Parts	22		
7.1 Rotor Group Components & Assembly	22		
7.2 Driveline Components	26		
7.3 Stub Shaft Components	29		
7.4 Belt Adjuster Components	30		
7.5 Bearing Support Plates Components	31		
7.6 Motor Components	34		
7.7 Hose Components	37		
7.8 Crossover Hose Components	39		
7.9 Door Components	40		
7.10 Stripper Plate Components	41		
7.11 Comb Kit Components	42		
7.12 Stone Guard Components	43		
7.13 Safety Decals	44		
8. Specifications	45		
8.1 Attachment Specifications	45		
8.2 Torque Specifications – Metric	46		

1. Introduction

1.1 Attachment Identification

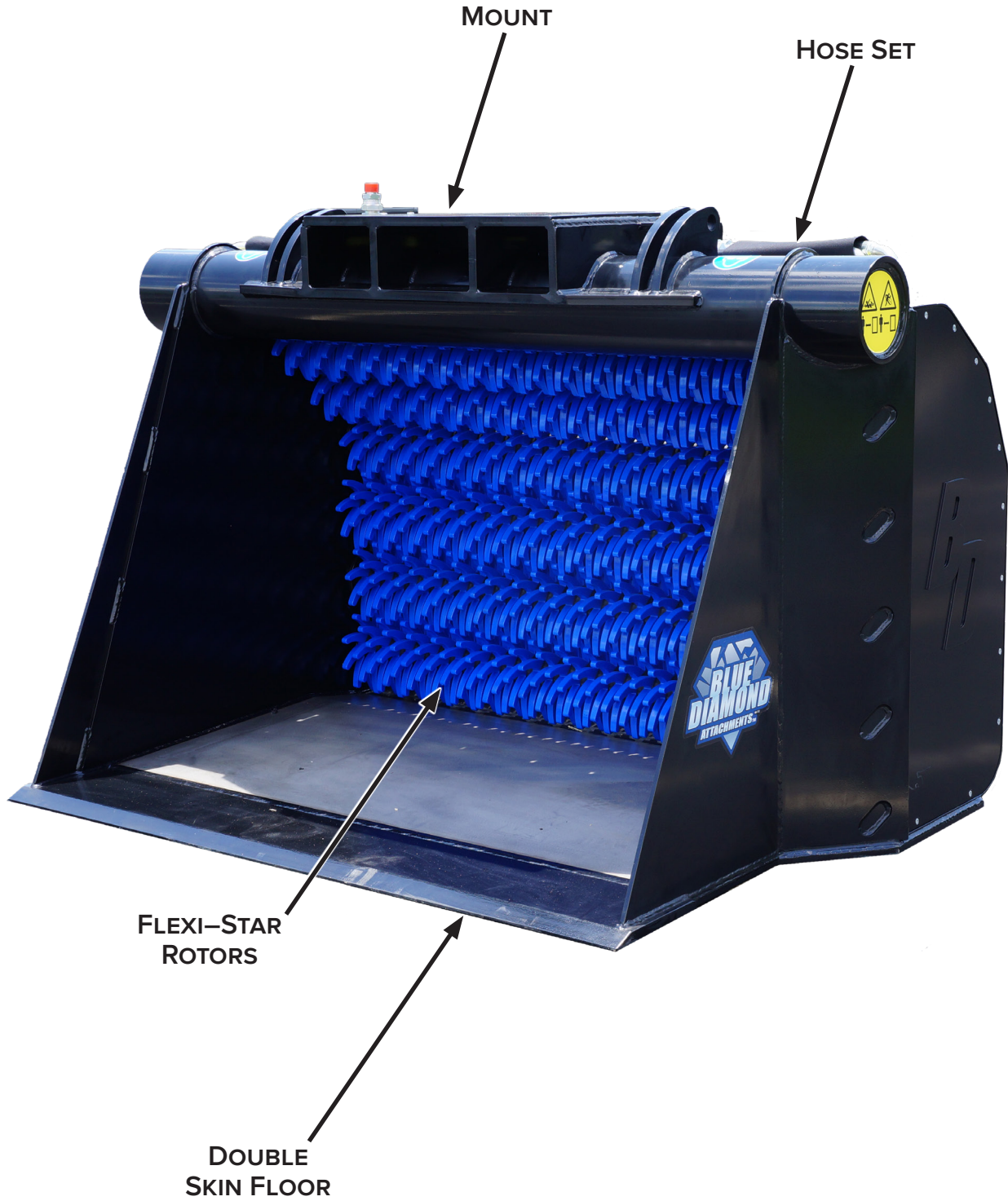

1. Introduction

1.2 About this Attachment

Intended Purpose

The Screening Bucket is to be used for the screening, aerating, separating, and mixing of soil, aggregates, woodchips, and compost. It is not meant to be used with clay and mud.

The Screening Bucket is to be used exclusively for the purpose intended (e.g. not as a primary digging bucket). The operator of the Screening Bucket is responsible for damage resulting from the Screening Bucket not being used for the purpose intended as well damage from not following the manufacturer's instructions for operation and maintenance.

Scope of Use

The Screening Bucket is a bucket type attachment fitted either to a hydraulic excavator or a skid steer loader (prime mover) that replaces a standard digging bucket.

The bucket shell is a steel structure with welded joints, integrated driveline cavities, double skin floor, and wear-resistant cutting edge.

The horizontal shafts are fitted with Polypropylene Flexi-Stars that rotate in the same upwards direction. The rotors are supported at each end by a sealed bearing unit and are driven by a hydraulic motor.

The hydraulic motor, driveline, and bearings are all housed within the main structure of the bucket with access via a bolted access panel.

Only screen non-hazardous material. Load the material into the Screening Bucket in the same manner as loading a standard excavator or wheeled loader bucket. Once the bucket has been loaded and positioned, the prime mover's auxiliary hydraulic circuit is activated causing the star rotors to turn in an upwards direction.

The efficient screening process is created by the star rotors agitating the material. The agitation causes the finer material to flow through the rotating stars leaving the oversized/larger material in the bucket.

The larger material can then be tipped out so the process can be repeated.

1.3 Attachment Model Numbers

MODEL NUMBER	WEIGHT OF EXCAVATOR	WIDTH
145135	35K – 53K lbs	60"

2. Safety

2.1 General Safety Information



This **SAFETY ALERT SYMBOL** identifies important safety messages on the equipment and in the owner's manual. When you see this symbol, be alert to the possibility of personal injury and carefully read the message that follows.



The signal word **IMPORTANT** identifies procedures which must be followed to avoid damage to the machine.



The signal word **DANGER** on the machine and in the manuals indicates a hazardous situation which, if not avoided, will result in death or serious injury.



The signal word **WARNING** on the machine and in the manuals indicates a potentially hazardous situation which, if not avoided, could result in death or serious injury.



The signal word **CAUTION** on the machine and in the manuals indicates a potentially hazardous situation which, if not avoided, may result in minor or moderate injury. It may also be used to alert against unsafe practices.

NOTE: Notes are used to indicate important information. This information may be repeated in other areas of the manual.

Terminology

Host Machine, Machine, Prime Mover:

- The Screening Bucket can be attached to many different pieces of equipment; therefore, the terms “host machine”, “machine”, and “prime mover” will be used. Host machine, machine, and prime mover mean any vehicle, excavator, or skid steer providing power to the attachment.

Attachment, Implement, Equipment:

- The Screening Bucket is the tool that is being attached to the host machine; therefore, the terms “attachment”, “implement”, and “equipment” will be used. The attachment, implement, and equipment mean any tool that is being used on any vehicle, excavator, or skid steer being used for different applications.

Operating Safety

- Read and follow instructions in this manual and the machine's Operator's Manual before operating.
- The manual must always remain with the machine. In case of loss or damage, request a new copy from your dealer or from Blue Diamond®.
- Strictly follow all rules prescribed by the safety pictograms/decals applied to the machine. Ensure that all safety pictograms/decals are legible. If pictograms/decals are worn, they must be replaced with new ones obtained from Blue Diamond® and placed in the position indicated by this manual.
- Before using the machine, make sure that all safety devices are installed and in good working condition. In case of damaged or missing shields, replace them immediately.
- It is absolutely forbidden to remove or alter safety devices and/or safety precautions
- Pay maximum attention to avoid any accidental contact with rotating parts of the machine.
- If the use of the machine is required at night or in conditions of reduced visibility, use the lighting system of the prime mover and an auxiliary lighting system if required.

2. Safety

2.2 Operators

Qualified Operators

The operator is a person suited to the work and who is physically and psychologically able to withstand the demands connected with operating the equipment for its intended use. The operator must not allow anyone to approach the machine while it is working and must not allow external personnel to operate the machine or attachment.

The operator is to follow the given instructions in this manual and the machine operator's manual in order to obtain maximum performance, minimal fuel consumption, and maximum safety for himself and for others.

The operator is responsible for scrupulously observing all the instructions given in this manual.



DANGER



AVOID SERIOUS INJURY OR DEATH

Operators must receive instructions before operating the machine. Untrained operators can cause serious injury or death.

For an operator to be qualified, he or she must not use drugs or alcoholic drinks which impair alertness or coordination while working. An operator who is taking prescription drugs must get medical advice to determine if he or she can safely operate a machine and the equipment.

For an operator to be qualified, he or she must have read and understood the instructions of this manual, he or she must make adequate preparation for the proper use of the machine, and he or she must hold a driving license.

In case of doubt regarding the use of the machine and/or the interpretation of this manual, the operator must contact either their dealer or Blue Diamond®.

Operator Training

- Check the rules and regulations at your location. The rules may include an employer's work safety requirements. Regulations may apply to local driving requirements or use of a Slow Moving Vehicle (SMV) emblem. Regulations may identify a hazard such as a utility line.
- The new operator must start in an area without bystanders and use all the controls until he or she can operate the machine safely under all conditions of the work area.

Operator Safety

- Any use of the machine other than the intended use is a non-intended use and is considered to be unauthorized and dangerous. Blue Diamond® is not liable for any damage or injury resulting from non-intended use.
- Prior to and during operation of the attachment, clear an operation area of 30 feet (10 m) in all directions.
- Before starting, and during operation of the attachment, make sure there are no people or animals in the operation area; the machine can project material with risks of serious injury or death.
- During operation, adjustment, maintenance, repairing, or transportation of the machine, the operator must always use appropriate Personal Protective Equipment (PPE) including but not limited to safety glasses, working gloves, dust mask, safety helmet, and hearing protection.
- Do not operate the attachment or machine while wearing loose fitting clothing that can be entangled or caught in parts of the machine.
- Do not operate the implement when tired, not in good condition, or under the influence of alcohol or drugs.

2. Safety

2.3 Safety Guidelines

Operating Safety

- Read and follow instructions in this manual and the machine's Operator's Manual before operating.
- Under no circumstances should young children be allowed to work with this equipment.
- This equipment is dangerous to persons unfamiliar with its operation.
- Check for overhead and/or underground lines before operating equipment.
- In addition to the design and configuration of equipment, hazard control and accident prevention are dependent upon the awareness, concern, prudence, and proper training of personnel involved in the operation, transport, maintenance, and storage of equipment.
- Check that the attachment is securely fastened to the machine.
- Make sure all the machine controls are in the NEUTRAL before starting the machine.
- Operate the equipment only from the operator's position.
- Operate the equipment according to the Operator's Manual.
- When learning to operate the equipment, do it at a slow rate in an area clear of bystanders.
- Do not permit personnel to be in the work area when operating the equipment.
- The equipment must be used ONLY on approved machines.
- Do not modify the equipment in any way. Unauthorized modification may impair the function and/or safety and could affect the life of the equipment.
- Do not make any adjustments or repairs on the equipment while the machine is running.
- Keep shields and guards in place. Replace if damaged.
- DO NOT operate equipment in poor visibility conditions such as fog, darkness, or any conditions that limit clear visibility less than 300 feet (100 m) in front of and to the sides of the equipment.
- When conditions make it necessary to slow ground speed, shift to a lower gear rather than reducing engine speed. The engine will maintain rated speed and keep the attachment running at optimum sifting speed.
- DO NOT operate in a work area that has not been inspected for foreign debris and obstacles.
- Remove any foreign objects and clearly mark any objects that cannot be removed.
- Wear safety glasses, gloves, hearing protection, and other protective clothing when required.

Machine Requirements and Capabilities

- Windshields are advised when operating the attachment.
- Keep bystanders clear of moving parts and the work area. Keep children away.
- Do not exceed 2900 psi (200 bar) operating pressure.
- See "8.1 Attachment Specifications" on page 45 for more information regarding host machine requirements.
- The host machine must be able to safely pick up the attachment while it is loaded.
- Use caution on slopes and near banks and ditches to prevent overturn.

2. Safety

2.3 Safety Guidelines Cont'd

Fire Prevention Safety

- Flammable debris (leaves, grass, etc.) must be removed regularly. If flammable debris is allowed to accumulate, it can cause a fire hazard. Clean often to avoid this accumulation.
- The equipment's hydraulic motor compartment must be inspected every day and cleaned if necessary to prevent fire hazards and overheating.
- All fuels, most lubricants, and some coolant mixtures are flammable. Flammable fluids that are leaking or spilled onto hot surfaces or onto electrical components can cause a fire.

Transporting Safety

- Comply with state and local laws governing highway safety and movement of machinery on public roads.
- Check local laws for all highway lighting and marking requirements.
- Always yield to oncoming traffic and move to the side of the road so any following traffic may pass.
- Never allow riders on either machine or equipment.
- If transporting the equipment on a truck or trailer, make sure the equipment is properly secured to the transport vehicle.

Hydraulic System

- Check hydraulic tubes, hoses, and fittings for damage and leakage. Never use open flame or bare skin to check for leaks.
- Hydraulic tubes and hoses must be properly routed and have adequate support and secure clamps. Tighten or replace any parts that show leakage.
- Always clean fluid spills. Do not use gasoline or diesel fuel for cleaning parts. Use commercial nonflammable solvents.

Personal Protective Equipment



Proper Work Clothes: To help ensure your safety as a designated operator, wear proper work clothes including tight fitting clothes, protective gloves, and shoes.



Hand Protection: To help ensure your safety as a designated operator, wear protective gloves.



Protective Shoes: To help ensure your safety as a designated operator, wear protective shoes.



Safety Helmet: To help ensure your safety as a designated operator, wear a safety helmet.



Safety Helmet and Eye/Ear Protection: To help ensure your safety as a designated operator, wear a safety helmet and eye/ear protection.

3. Operation

3.1 Pre–Operation Inspection

Before operating the Screening Bucket for the first time and each time thereafter, use the following list as a guideline during equipment inspection.



WARNING



AVOID SERIOUS INJURY OR DEATH

- Disengage machine’s auxiliary hydraulics, engage the machine’s parking brake, stop the engine, and make sure all moving parts are completely stopped before connecting, disconnecting, adjusting, or cleaning equipment.
 - Always keep shields and guards in place when using the equipment.
 - Disengage machine’s auxiliary hydraulics for road travel.
 - Keep hands, feet, and clothing away from rotating parts.
-
- Remove metal bar labeled “For Transport Use Only” from the Screening Bucket.
 - Check the attachment mounting frame for damage or cracks.
 - Check that all shields and guards are in place.
 - Check for loose bolts and tighten them if necessary. See “8.2 Torque Specifications – Metric” on page 46 for additional information.
 - Check all welds on the attachment for wear and damage each time the attachment is removed from the machine.
 - Check for damaged or missing safety decals. Replace if necessary.
 - Inspect the machine’s mounting frame. (See the machine’s Operator’s Manual for inspecting the mounting frame.)
 - Replace any parts that are damaged, bent, or missing. Keep all fasteners tight. Look for cracked welds.
 - Verify that the attachment is properly connected to the machine.



WARNING



Leaking fluids under pressure can enter the skin and cause serious injury or death. Immediate medical attention is required.

Wear goggles. Use cardboard to check for leaks.

- Check the condition of all hydraulic components for leaks. Repair as required.

NOTE: Do not operate with hydraulic leaks.

3.2 Entering and Exiting the Prime Mover



IMPORTANT



See the machine’s Operator’s Manual for detailed information on operating the loader.

Entering the Operator’s Position

Use the safety treads, handles, and steps on the attachment and machine to enter the operator’s position. Always maintain three (3) points of contact.

When in the operator’s position, secure the seatbelt, lower safety seat bar, start the engine, and release the parking brake.

3. Operation

3.2 Entering and Exiting the Prime Mover Cont'd

Leaving the Operator's Position



WARNING



AVOID SERIOUS INJURY OR DEATH

- Always park on a flat level surface.
- Lower lift arms and place attachment flat on the ground.
- Place all controls in NEUTRAL.
- Engage the park brake.
- Stop the engine and remove the key.
- Wait for all moving parts to stop.

SEE MACHINE'S OPERATOR'S MANUAL FOR ADDITIONAL INFORMATION.

Park the machine/attachment on a flat, level surface.

Place all controls in neutral, engage the parking brake, stop the engine, and wait for all moving parts to stop. Leave the operator's position.

3.3 Attachment Installation with Excavator

Connecting Attachment to the Machine



WARNING



AVOID SERIOUS INJURY OR DEATH

The locking pins must extend through the holes in the attachment mounting frame. Failure to secure locking pins can allow attachment to come off.

SEE MACHINE'S OPERATOR'S MANUAL FOR ADDITIONAL INFORMATION.

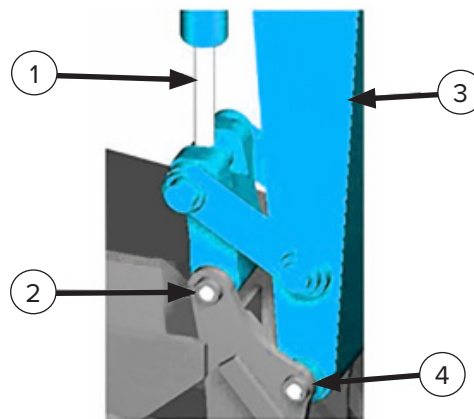

Figure 1

Order the appropriate bracket interchange from your local Blue Diamond® Attachments dealer by supplying the brand and model information of your machine.

The bracket interchange is secured to the attachment with bolts.

Use an appropriate lifting device and slings to place the bracket interchange onto the attachment.

Align the holes between the bracket interchange and deck. Install the appropriate hardware.

Torque hardware to the specification detailed in the "8.2 Torque Specifications – Metric" on page 46.

Position the excavator at the rear of the attachment.

Extend the tool cylinder [Figure 1, Item 1] and paddle until the pin position is aligned.

Leave the operator's position. See "Leaving the Operator's Position" on page 11.

Install the pin through the attachment and paddle. Secure with appropriate hardware.

Enter the operator's position. See "Entering the Operator's Position" on page 10.

Adjust the height of the dipperstick [Item 3] to align with the pin position [Item 4].

Leave the operator's position. See "Leaving the Operator's Position" on page 11.

Install the pin through the attachment and paddle. Secure with appropriate hardware.

NOTE: Some excavators are equipped with hydraulic locking systems, which are operated from the cab of the machine.

3. Operation

3.3 Attachment Installation with Excavator Cont'd

Connecting Hydraulic Hoses



Thoroughly clean the quick couplers before making connections. Dirt can quickly damage the hydraulic system.

Verify that all hydraulic couplings are compatible with the host machine.

Remove dirt or debris from the male and female couplers. Visually inspect the couplers for corroding, cracking, damage, or excessive wear. Replace as needed.

Connect the attachment hydraulic hoses to the machine. The hydraulic hoses must be connected in the following order: return hose then pressure hose.

For the hydraulic hoses, the return hose must be connected before the pressure hose.

Pull on each hose to verify full connection is made.

Disconnecting Hydraulic Hoses



AVOID SERIOUS INJURY OR DEATH

Hydraulic fluid, tubes, fittings, and quick couplers can get hot during operation. Be careful when connecting and disconnecting hydraulic hoses.

Relieve auxiliary hydraulic pressure. (See the machine's Operator's Manual for correct procedure.)

Disconnect attachment hydraulic hoses from the machine. The hoses must be disconnected in the following order: pressure hose then return hose.

The pressure hose must be disconnected before the return hose.

Disconnecting Attachment From the Machine

Relieve auxiliary hydraulic pressure. (See the machine's Operator's Manual for correct procedure.)

Park the machine and attachment on a flat, level surface. Lower the attachment flat on the ground.

Leave the operator's position. See "Leaving the Operator's Position" on page 11.

Disconnect attachment hydraulic hoses from the machine.

Remove hardware securing the pins and remove the pins from the paddle and attachment.

Enter the operator's position. See "Entering the Operator's Position" on page 10.

Raise the dipperstick to clear the attachment.

Drive the machine slowly backward, away from the attachment.

3.4 Operating the Attachment

General Operation Guidelines

- The Screening Bucket should only be lifted or moved by the mounting bracket securely attached to the machine.
- The Screening Bucket must be placed on firm, level ground when it is detached from the machine.
- Never stand or walk under a suspended load.
- When transporting the Screening Bucket, adhere to all local and national regulations of the country in which the Screening Bucket is being transported in.

3. Operation

3.4 Operating the Attachment Cont'd

Operating Instructions

The Screening Bucket is designed as a rehandling bucket only for screening, aeration, and mixing of nonhazardous, pre-dug material. It is not to be used as a primary digging bucket for use in contaminated areas. It is also not meant to be used to screen mud or clay.

The material to be screened should be loaded into the Screening Bucket in the same manner as a standard excavator or skid steer bucket. Once the bucket has been loaded with material to be screened and positioned, the host machine's auxiliary hydraulic circuit is activated, causing the star rotors to turn in an upwards direction.

Rotor Direction

Ensure that the rotors are rotating in the correct direction or serious damage can occur [Figure 2].

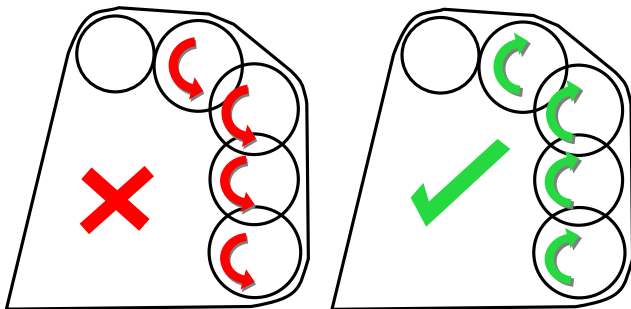

Figure 2

Operation Angle

Keep the Screening Bucket at the appropriate angle for maximum performance [Figure 3].

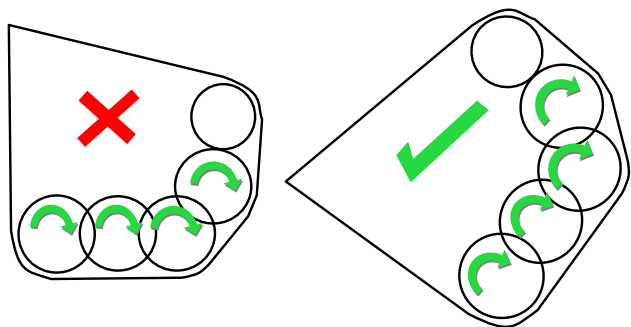

Figure 3

Material Handling

Do not overload the Screening Bucket as this will reduce the performance of the screening process and can damage your Screening Bucket [Figure 4].

NOTE: If the operator cannot see the top row of poly stars, there is too much material in the Screening Bucket.

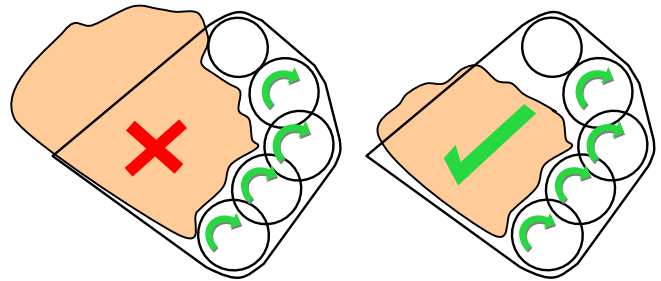

Figure 4

The Screening Bucket's efficient screening process is created by the star rotors responsible for agitating the prescreened material inside the bucket, allowing fine material to flow through the star rotors and leaving larger material inside the bucket to be dumped out in a different location [Figure 5].

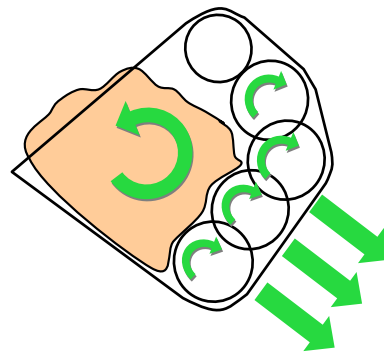

Figure 5

4. Maintenance

4.1 Service Schedule

DESCRIPTION	SERVICE PROCEDURES					
	Check	Clean	Lube	Change	Adjust	Drain
Daily Maintenance (or every 8 hours)						
Hydraulic Fittings	•					
Hydraulic Hoses	•					
Flexi-Stars (wear, damage, and loosening)	•					
Mounting Frame	•					
Rotor Shafts	•					
All Hardware	•					
Monthly Maintenance						
Flexi-Stars (wear, damage, and loosening)	•					
Flexi-Star Rotor Bearings	•					
All Hardware	•					

4. Maintenance

Proper and regular maintenance ensures a long life of the attachment, avoids failures, and saves times and repair costs.

Periodic inspections and maintenance operations described in this section must be performed by an operator in times and terms prescribed. Failure to comply with maintenance prescriptions can compromise the function and lifetime of the attachment, which will result in the warranty becoming void.

Repairs, maintenance, and modifications other than those mentioned in this manual should NOT be performed without consulting Blue Diamond® Product Support.

Wrong or inappropriate repairs or maintenance may generate abnormal operating conditions, equipment damage, and generate risks for the operator.



WARNING



AVOID SERIOUS INJURY OR DEATH

The following must always be performed prior to any adjustment being made:

- Always park on a flat, level surface.
- Lower lift arms, and place attachment flat on the ground.
- Place all controls in NEUTRAL.
- Engage the parking brake.
- Stop the engine, and remove the key.
- Wait for all moving parts to stop.
- Set the parking stand.

SEE MACHINE'S OPERATOR'S MANUAL FOR ADDITIONAL INFORMATION.

4.2 Maintenance Safety



WARNING



AVOID SERIOUS INJURY OR DEATH

Never operate the host machine in a closed building. Proper ventilation is required when operating the machine under all circumstances.

- Always keep the work area clean and dry.
- Always use personal protective equipment (PPE) such as eye, hand, and hearing protection when performing any service or maintenance.
- A fire extinguisher and first aid kit should be readily accessible while performing maintenance on this machine.
- Before working or doing maintenance on this machine, shut off the engine and remove the key. Make sure the machine's wheels are blocked.
- Never work under the machine or attachment unless the machine or attachment is blocked or securely supported.
- Disconnect the battery (both terminals) before welding any part of the machine. Failure to do so may cause damage to the electrical components.
- When working around batteries, remember that all of the exposed metal parts are "live". Never lay a metal object across the terminals because a spark, short circuit, explosion, or personal injury may result.
- Battery posts, terminals, and related accessories contain lead and lead compounds. Wash hands after handling.
- Always relieve hydraulic system pressure before repairing, adjusting, or disconnecting. Never search for leaks with your hands. (See "Disconnecting Hydraulic Hoses" on page 12.)

4. Maintenance

4.2 Maintenance Safety Cont'd

- When replacement parts are necessary, genuine factory replacement parts must be used to store your attachment to original specifications. Blue Diamond® will not be responsible for injuries or damage caused by use of unapproved parts and/or accessories.
- When completing service or maintenance on this attachment, make sure all shields and guards are installed before operating the attachment.

4.3 Daily Maintenance

Inspect all components and hardware to ensure the equipment is secure and thoroughly tightened.

Inspect all frame and welds for cracks or damage.

Check the mounting frame for proper operation and signs of damage and unusual wear.

Remove any material wrapped around the star rotor shafts.

Check hydraulic hoses and fittings for wear, damage, leaks, etc.

Visually inspect the host machine, ensuring all fixing pins are correctly fitted. Check the host machine's Operator's Manual for additional information.

Repair or replace any damaged parts.

After initial use and after replacing parts, check parts for proper bolt torque and operation.

4.4 Monthly Maintenance

Check the star rotor bearings for wear and replace if necessary.

Check the rotors for damaged stars. Replace if necessary.

4.5 Flexi-Star Replacement

When flexi-stars become damaged, they will need replaced. To replace them, perform the following:

1. Place the Screening Bucket on a flat, level surface and disconnect from the host machine.
2. Remove both driveline covers, one on each side.
3. Remove the bearing support plate.
4. Remove the carbon chain belt and the drive wheel by releasing the carbon belt adjuster of the intended rotor.
5. Support the flexi-star, and remove the hardware belonging to both rotor support bearings. The hardware consists of a bearing support plate and three (3) flange nuts or three (3) bolts.
6. With the rotor supported, remove both stub shaft assemblies including the bearings from the rotor shaft.
7. Remove the flexi-star discs by sliding them from the square section of the shaft. Be sure to take note of the staggered pattern.
8. To assemble, perform these steps in reverse.

NOTE: Ensure all the flexi-stars face the same direction in a staggered pattern that should have been noted during disassembly.

4. Maintenance

4.6 Comb Kits & Stripper Plates (Optional)

Blue Diamond® offers comb kits as an optional accessory to the Screening Bucket. Comb kits prevent larger material from entering the bucket, which can help protect the bucket from potential damage typically caused by larger material. The combs do not allow larger material into the bucket, which results in a finer, more precise screening of the material.

Stripper plates are another accessory that can be installed onto the Screening Bucket. Stripper plates are used to reduce the gap between the bucket and the top rotor as the stars wear.

To install a comb kit, perform the following:

1. Remove any debris from the area between the top lip and the tube. This is where the comb kit will go.
2. Arrange the comb kit to where all pieces will fit onto the Screening Bucket.
3. Stack the spring washer and then the flat washer onto the bolt.
4. While holding the comb to the appropriate area on the attachment, insert the bolt with the washers stacked on top into the bolt hole.
5. Handtighten the hardware into the Screening Bucket.
6. Insert the rest of the hardware into the comb.
7. Repeat the steps above until all combs and hardware are installed onto the attachment.
8. Once all hardware has been handtightened and all combs have been installed, properly torque the bolts according to “8.2 Torque Specifications – Metric” on page 46.

NOTE: The above instructions can be used to install the stripper plate onto the Screening Bucket. Instead of installing multiple pieces like the comb bit, the stripper plate is one plate.

4.7 Storage

Storage

Sometimes it may be necessary to store your Screening Bucket for an extended period of time. Below is a list of items to perform before storage.

- Make sure the hydraulic hose couplers are capped, plugged, or connected to each other.
- Thoroughly wash the attachment before storing it for long periods.
- Check for loose hardware, missing guards, or damaged parts.
- Check for damaged or missing decals. Replace if necessary.
- Replace worn or damaged parts.
- Place the attachment flat on the ground in a dry, protected shelter.

NOTE: In muddy conditions or to prevent the attachment from freezing to the ground, put the attachment on planks or blocks before removing the attachment from the machine.

Return to Service

After the Screening Bucket has been in storage, it is necessary to follow a list of items to return the attachment to service.

- Connect and operate the attachment and check for correct function.
- Check for leaks. Repair as needed.

4. Maintenance

4.8 Troubleshooting

PROBLEM	CAUSE	SOLUTION
Rotors do not rotate when the host machine's hydraulic circuit is engaged.	Host machine's hydraulic circuit loaded incorrectly	See Hydraulic Circuits on page 20.
	QRC couplers fitted incorrectly	Connect, repair, or replace for correct QRC couplings.
	Screening Bucket overloaded with material.	Dump out some material. Contact Blue Diamond® Product Support for further assistance.
	Skid steer auxiliary circuit inoperative	Investigate and repair.
	Motor shaft couplings defective	Replace couplings. Contact Blue Diamond® Product Support for further assistance.
	Hydraulic motor defective	Replace hydraulic motor. Contact Blue Diamond® Product Support for further assistance.
Only top rotor rotates	Host machine's hydraulic circuit loaded incorrectly	See Hydraulic Circuits on page 20.
Top rotor rotates, and one or more do not rotate	Broken or damaged carbon belt	Replace broken or damaged carbon belt. Contact Blue Diamond® Product Support for further assistance.
	Carbon belt slipping	Check the belt adjuster. Contact Blue Diamond® Product Support for further assistance.
	Rotor stub shaft failed	Replace broken or damaged stub shaft. Contact Blue Diamond® Product Support for further assistance.

**This page intentionally
left blank**

5. Hydraulic Circuit Patterns

5.1 Hydraulic Circuit Pattern for All Models

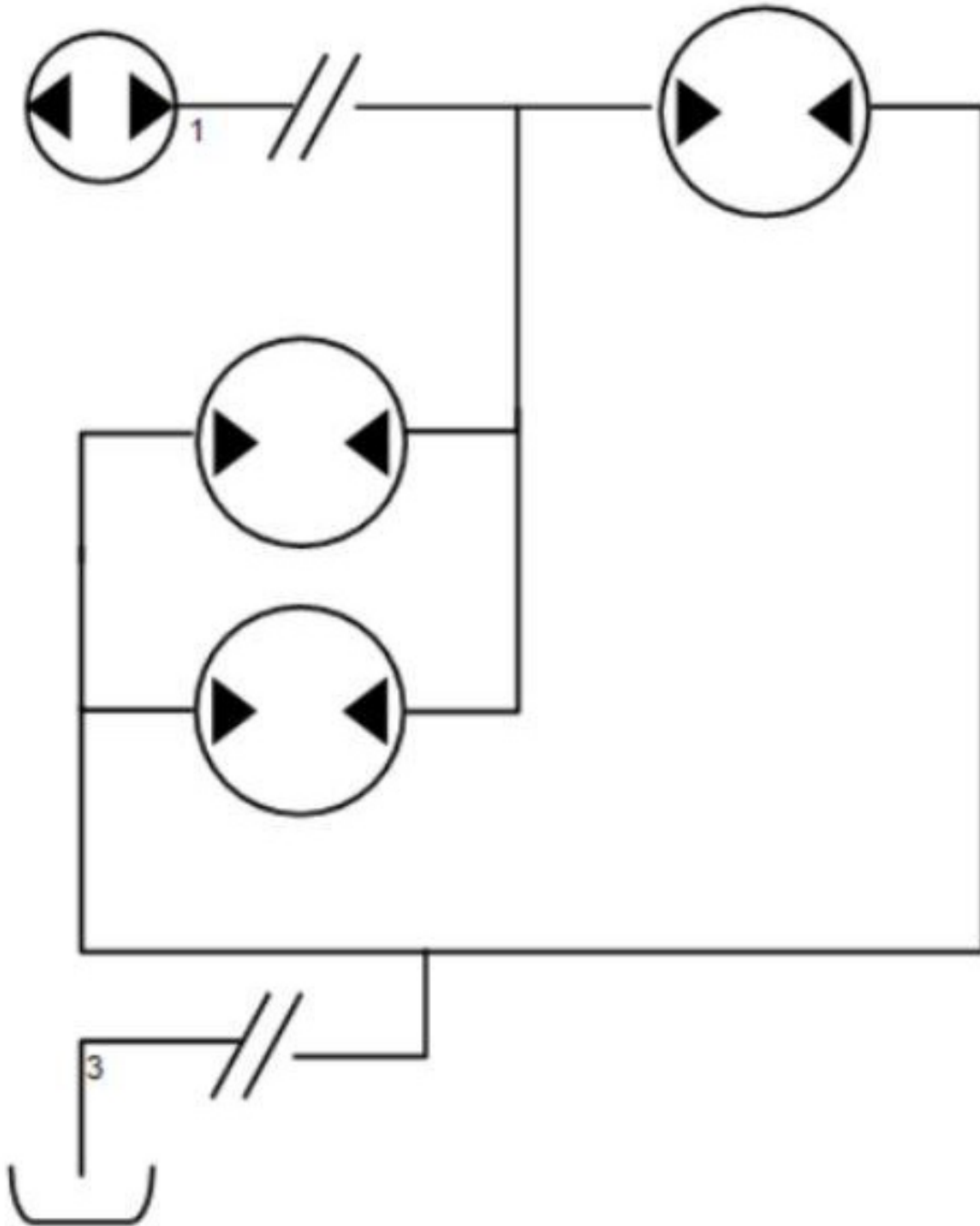

6. Drill Patterns

6.1 Drill Pattern for All Models

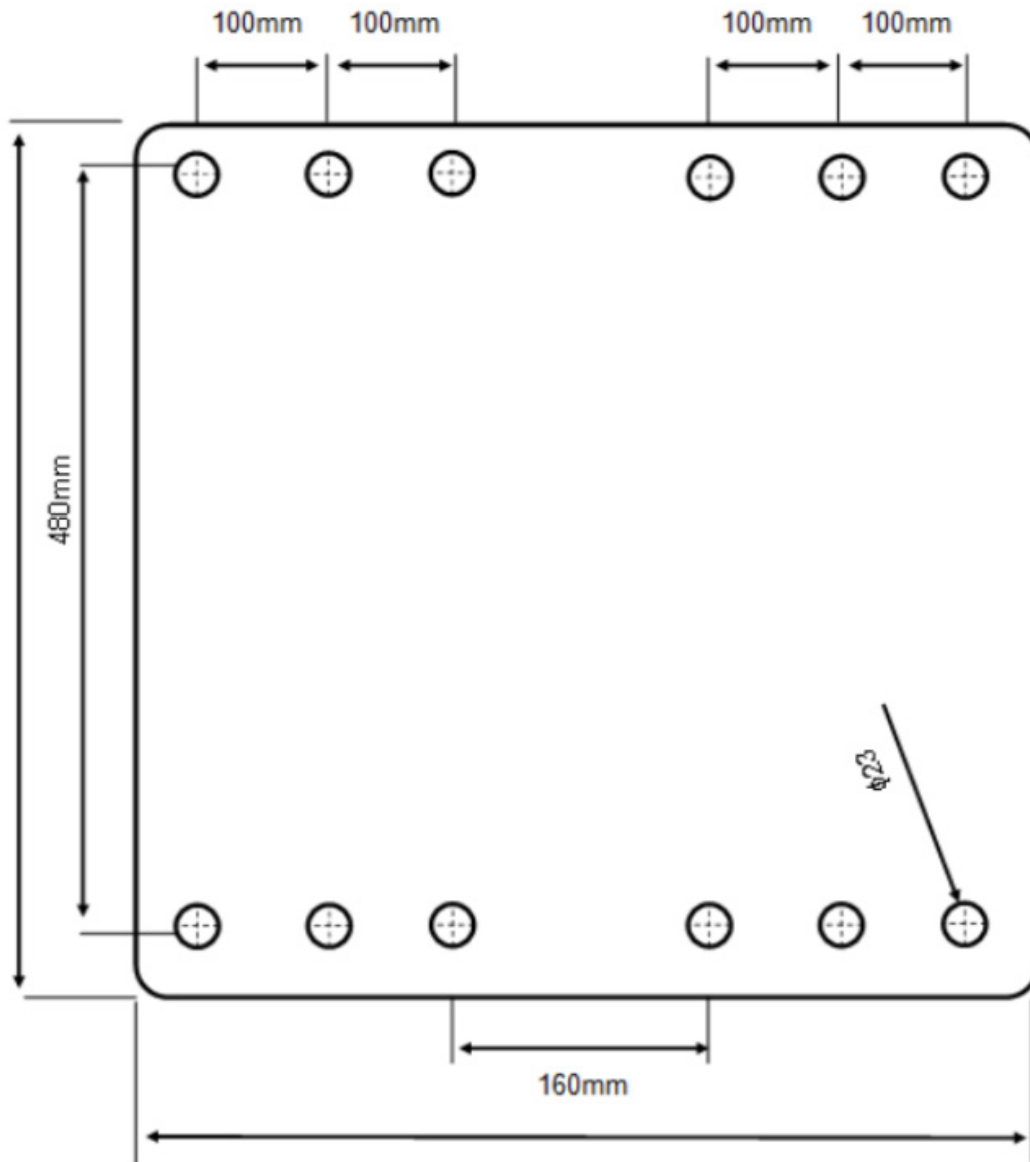

7. Parts

7.1 Rotor Group Components & Assembly

Rotor Group Overview

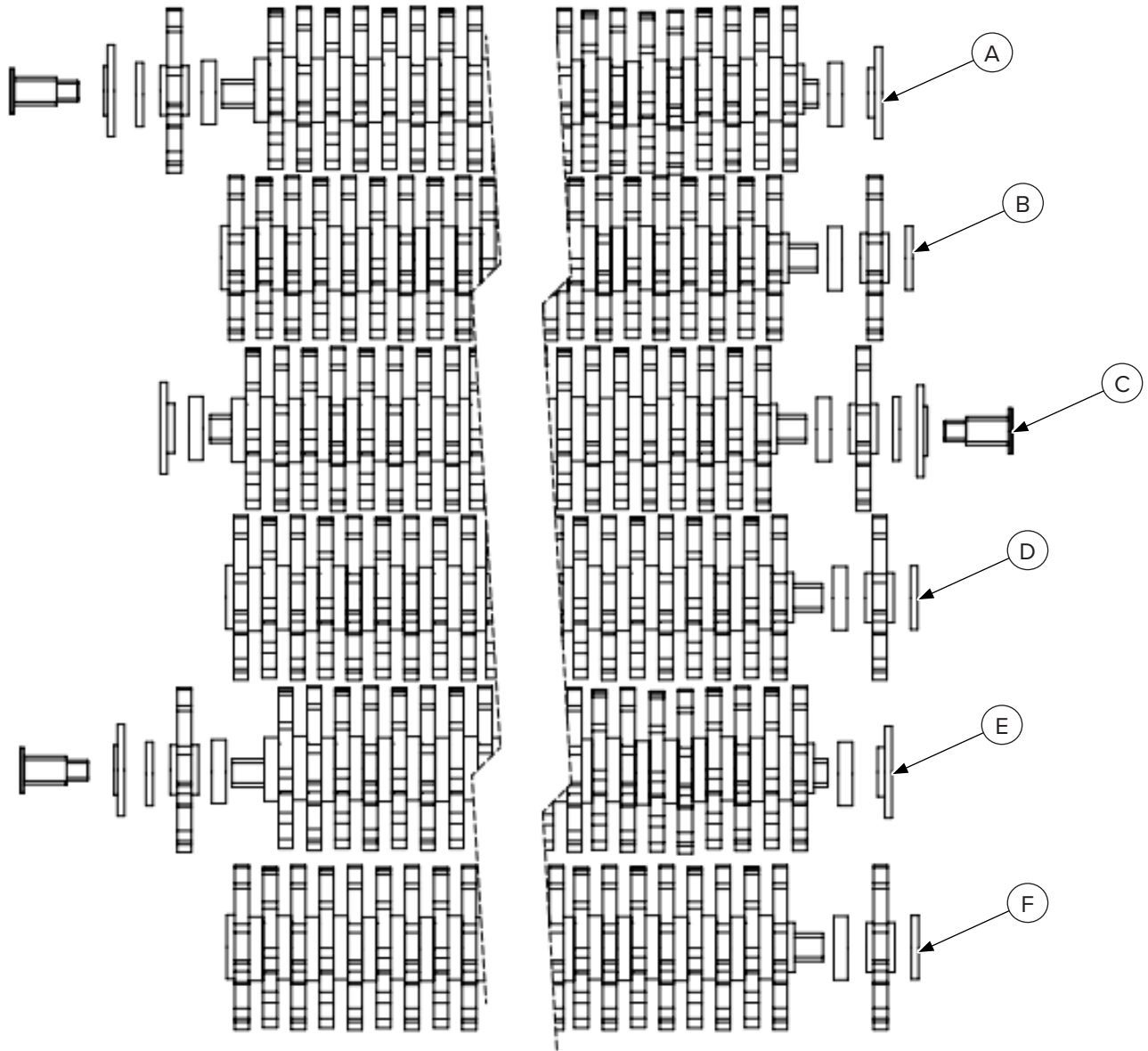

7. Parts

7.1 Rotor Group Components & Assembly Cont'd

Rotor Shaft A & E

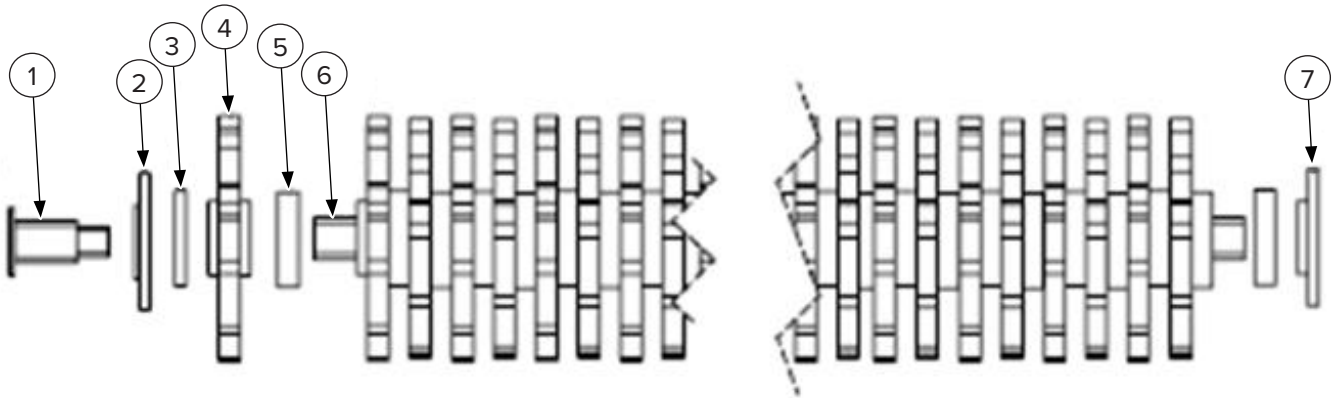

ITEM	PART NUMBER	DESCRIPTION	145135 QTY
ROTOR A & ROTOR E – Parts Listed Below Are for One (1) Group			
1	—	SAE Splined Drive Coupling	1
2	245025	15 mm End Cap	1
3	—	Nylon Locking Ring 90 mm OD	1
4	245000	Poly Star (230 mm Ten Finger) Blue	37
5	245030	20 mm Locking Ring	37
6	—	Rotor Shaft for 145135 (Motor Pickup)	1
7	245020	20 mm End Cap	1

7. Parts

7.1 Rotor Group Components & Assembly Cont'd

Rotor Shaft C

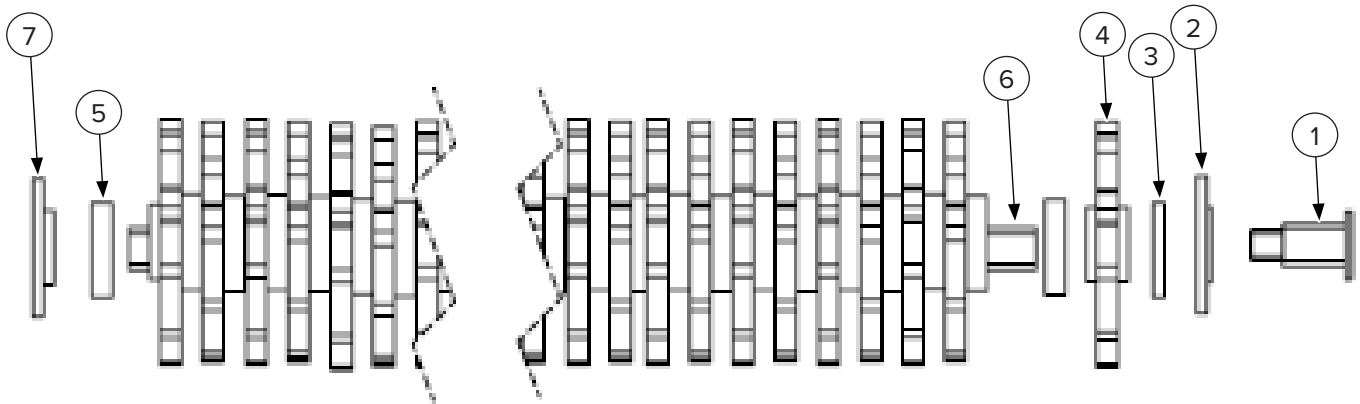

ITEM	PART NUMBER	DESCRIPTION	145135 QTY
ROTOR C			
1	—	SAE Splined Drive Coupling (HD)	1
2	245025	15 mm End Cap	1
3	—	Nylon Locking Ring 90 mm OD	1
4	245000	Poly Star (230 mm Ten Finger) Blue	37
5	245030	20 mm Locking Ring	37
6	—	Rotor Shaft for 145135 (Motor Pickup)	1
7	245020	20 mm End Cap	1

7. Parts

7.1 Rotor Group Components & Assembly Cont'd

Rotor Shaft B, D, & F



ITEM	PART NUMBER	DESCRIPTION	145135 QTY
ROTOR B, D, & F – Parts Listed Below Are for One (1) Group			
3	—	Nylon Locking Ring 90 mm OD	2
4	245000	Poly Star (230 mm Ten Finger) Blue	38
5	245030	20 mm Locking Ring	38
8	—	Rotor Shaft for 145135 (Motor Pickup)	1

Rotor Assembly – 145135

PART NUMBER	DESCRIPTION	QTY
—	Complete Rotor Assembly for 145135 (Includes all items below)	1
—	Driven Motor Shaft	2
—	Driven Reversed Motor Shaft	1
—	Non-Driven Shaft	3

Poly Star Kit – Contains all stars needed for total replacement

PART NUMBER	DESCRIPTION	QTY
245000-KIT-225	Poly Star Kit for 145135	1

7. Parts

7.2 Driveline Components

Group A

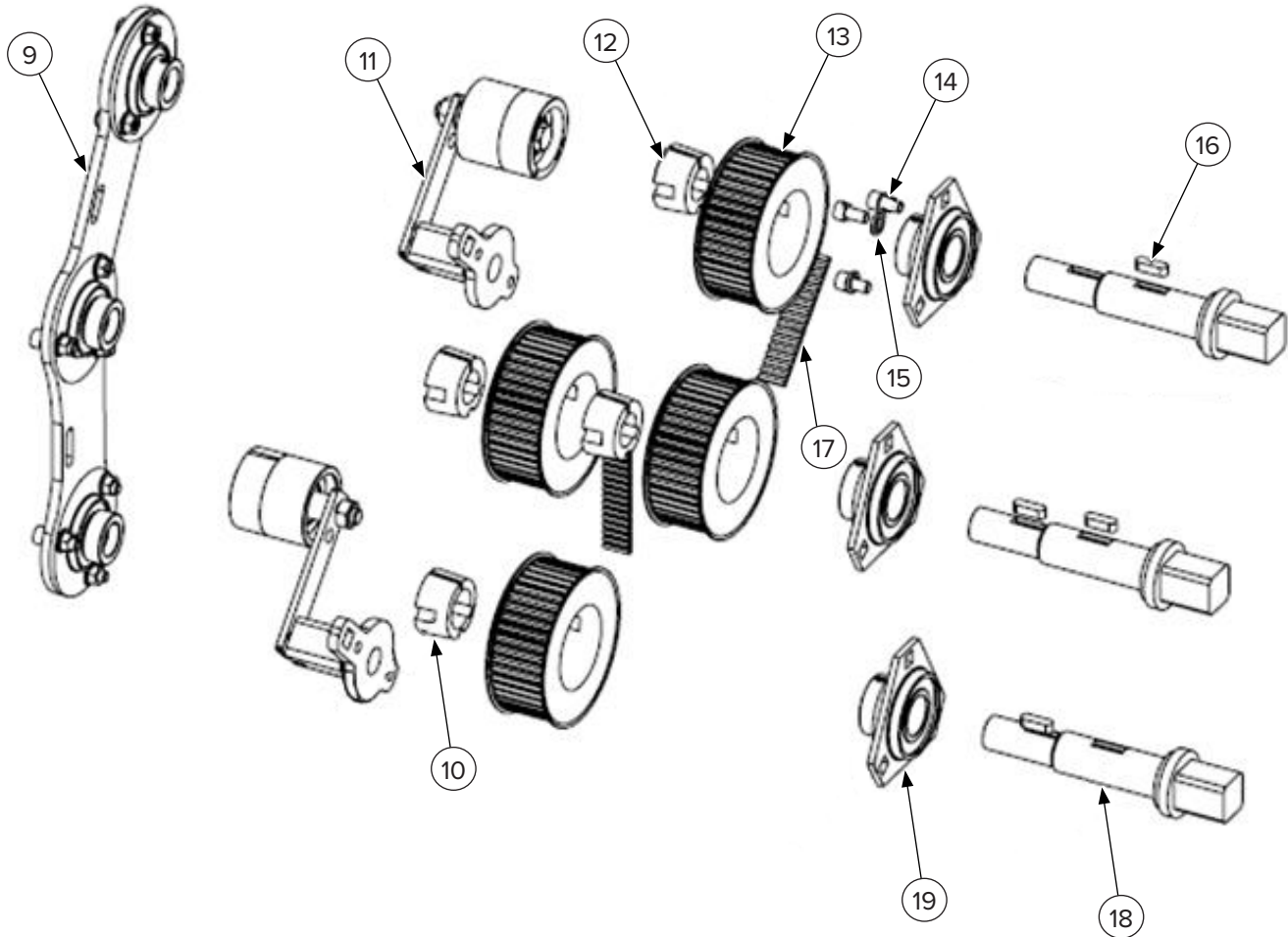

ITEM	PART NUMBER	DESCRIPTION	145135 QTY
GROUP A			
9	See page 32	Bearing Support Plate A	1
10	245100	Taper Bush 2012-25	2
11	See page 30	Belt Adjuster	1
12	245105	Taper Bush 2012-30	2
13	245050	Carbon Belt Pulley (8MDC3645)	4
14	—	M10 x 16 mm Socket Cap Screw	9
15	—	M10 Spring Washer	9
16	245124	Key	4
17	245060	Carbon Belt (8MDC-37)	2
18	—	Keyed Shaft	3
19	—	Bearing SLFT30C99	3

7. Parts

7.2 Driveline Components Cont'd

Group B

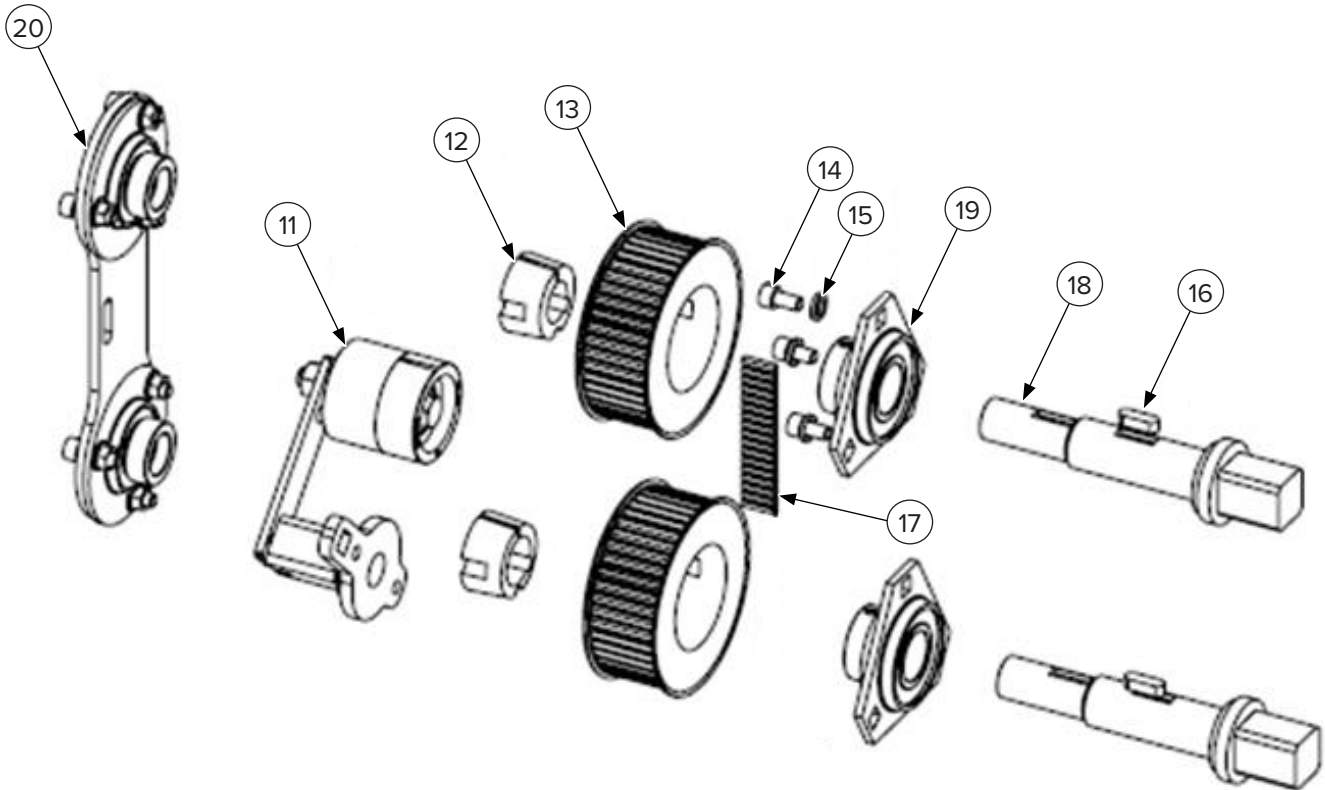

ITEM	PART NUMBER	DESCRIPTION	145135 QTY
GROUP B			
11	See page 30	Belt Adjuster	1
12	245105	Taper Bush 2012-30	2
13	245050	Carbon Belt Pulley (8MDC3645)	2
14	—	M10 x 16 mm Socket Cap Screw	6
15	—	M10 Spring Washer	6
16	245124	Key	4
17	245060	Carbon Belt (8MDC-37)	2
18	—	Keyed Shaft	2
19	—	Bearing SLFT30C99	2
20	See page 38	Bearing Support Plate B	1

7. Parts

7.2 Driveline Components Cont'd Group C

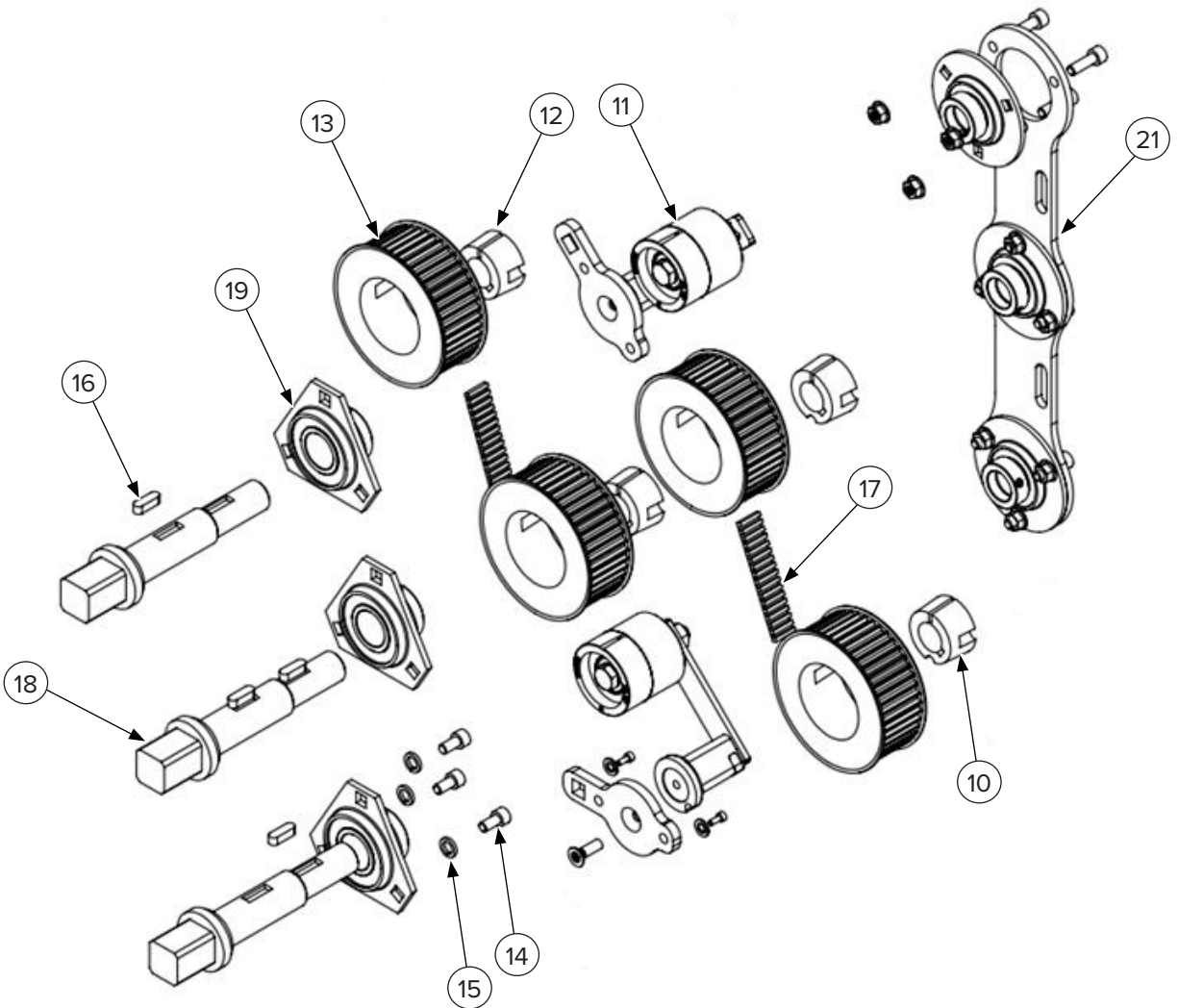

ITEM	PART NUMBER	DESCRIPTION	145135 QTY
10	245100	Taper Bush 2012-25	2
11	See page 30	Belt Adjuster	1
12	245105	Taper Bush 2012-30	4
13	245050	Carbon Belt Pulley (8MDC3645)	4
14	—	M10 x 16 mm Socket Cap Screw	9
15	—	M10 Spring Washer	9
16	245124	Key	5
17	245060	Carbon Belt (8MDC-37)	2
18	—	Keyed Shaft	3
19	—	Bearing SLFT30C99	3
21	See page 32	Bearing Support Plate C	1

7. Parts

7.3 Stub Shaft Components

For 145135 Models 2024 & Newer Only

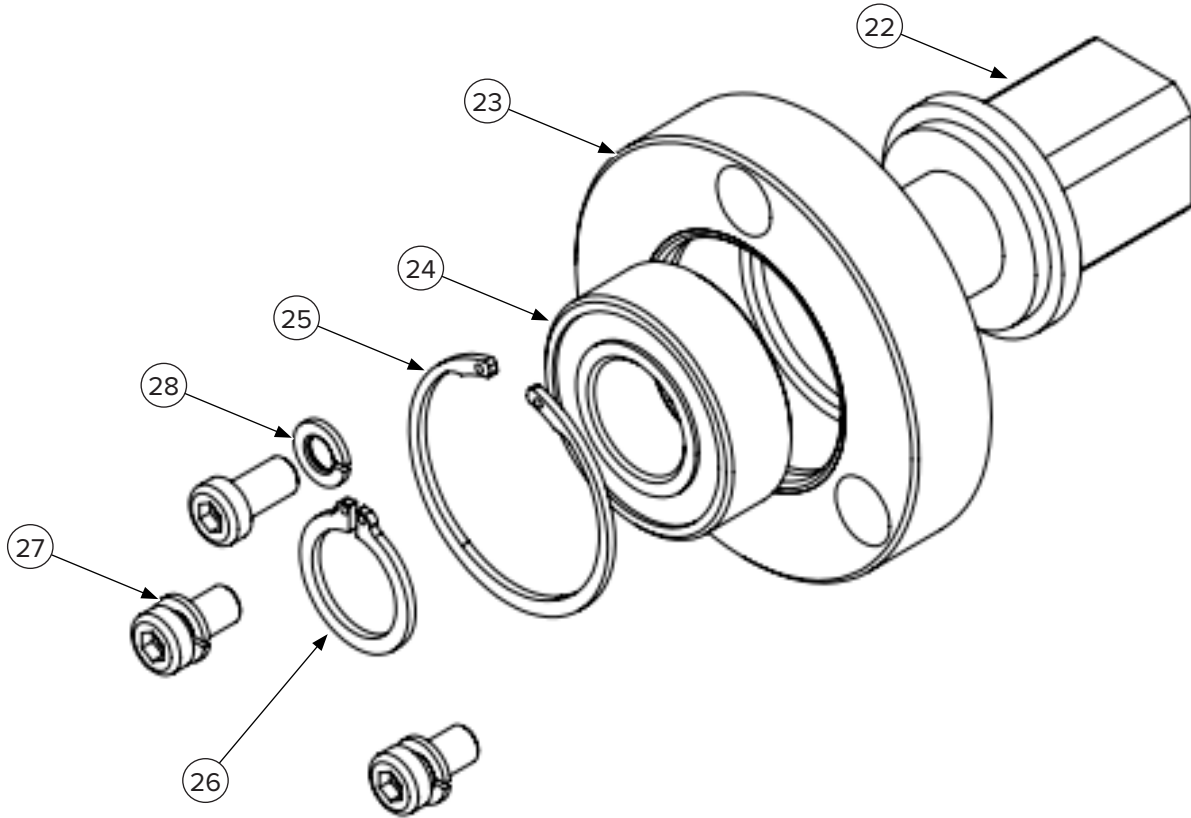

ITEM	PART NUMBER	DESCRIPTION	145135 QTY
22	—	Short Stub Shaft	1
23	—	Bearing Housing	1
24	—	32052RS Bearing	1
25	—	Circlip D1360 52 mm	1
26	—	M8 Spring Washer	3
27	—	M8 x 16 mm Socket Cap Screw	3
28	—	Circlip D1460 25mm	1

NOTE: The new stub shaft assembly can be fitted into all pre-2024 models with no other modifications required.

Short Stub Shaft Assembly – 145135

PART NUMBER	DESCRIPTION	QTY
—	Complete Short Stub Shaft Assembly for 145135 (Includes all items below)	1
—	Keyed Shaft	1
—	Bearing SLFT30C99 with Housing	1
—	Bearing Unit for 6 Rotor Models	1

7. Parts

7.4 Belt Adjuster Components

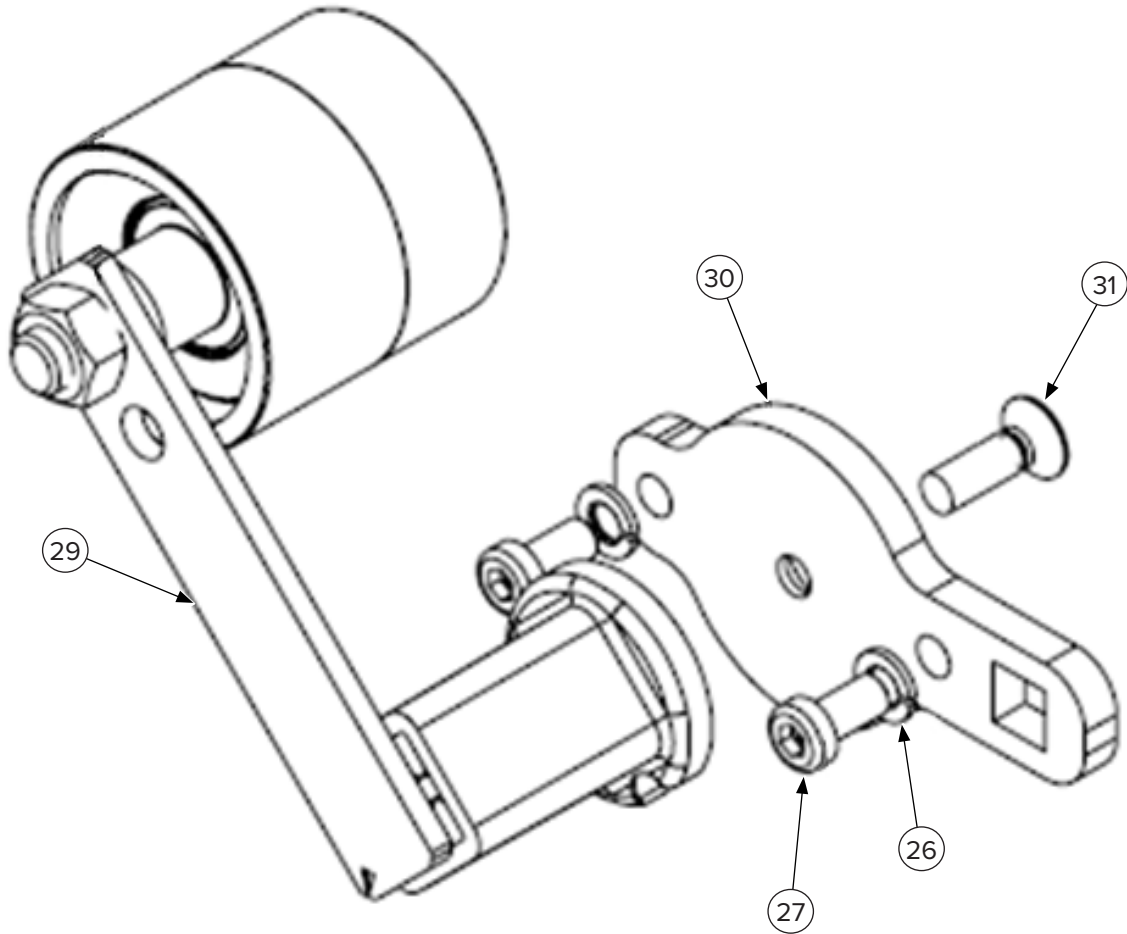

ITEM	PART NUMBER	DESCRIPTION	145135 QTY
26	—	M8 Spring Washer	8
27	—	M8 x 16 mm Socket Cap Screw	8
29	245150	Rosta Belt Adjuster	4
30	—	Belt Adjuster Plate	4
31	—	M8 x 25 mm Stainless Steel Socket Countersunk Screw	4

7. Parts

7.5 Bearing Support Plates Components

Bearing Support Group Overview

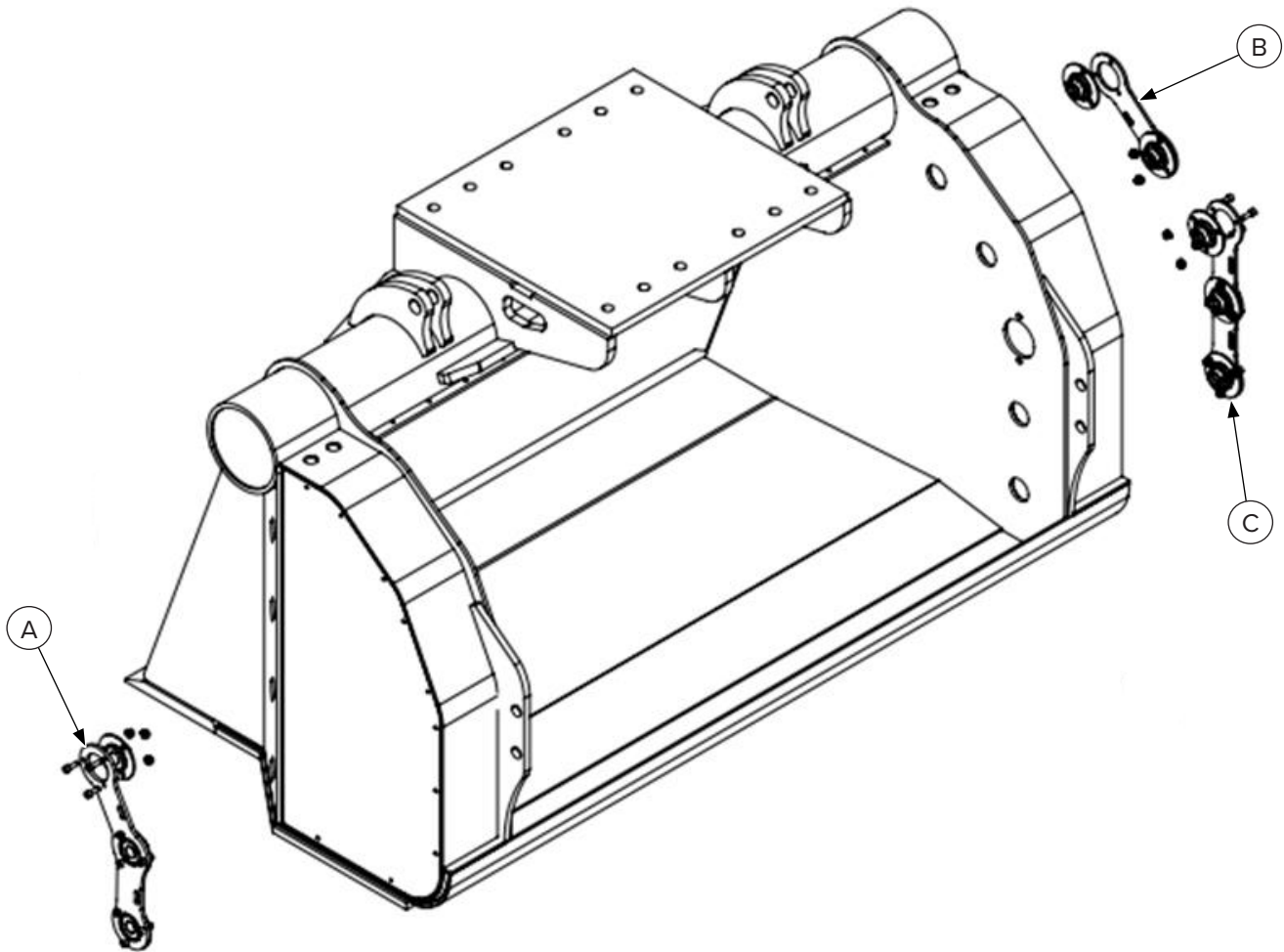

7. Parts

7.5 Bearing Support Plates Components Cont'd Group A & C

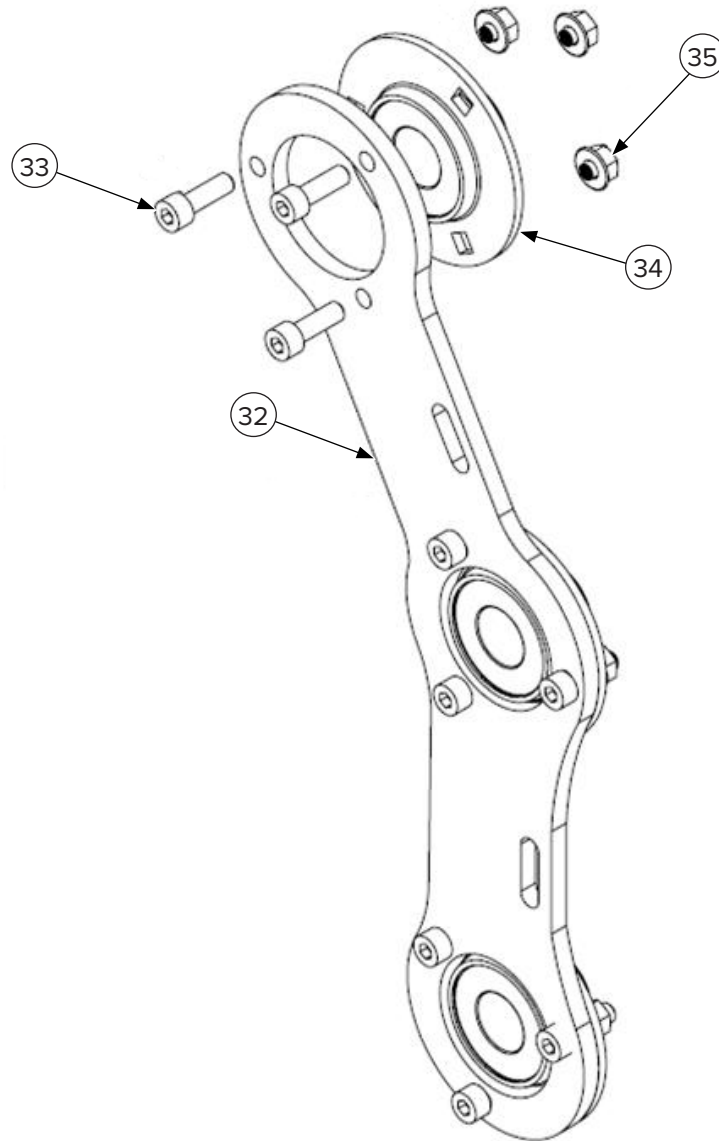

ITEM	PART NUMBER	DESCRIPTION	145135 QTY
GROUP A & C – Parts Listed Below Are for One (1) Group			
32	—	Angled Bearing Support Plate	1
33	—	M8 x 20 mm Socket Cap Screw	9
34	245120	Bearing SLFE25C99 with Housing	3
35	299343	M8 Flange Nut	9

7. Parts

7.5 Bearing Support Plates Components Cont'd Group B

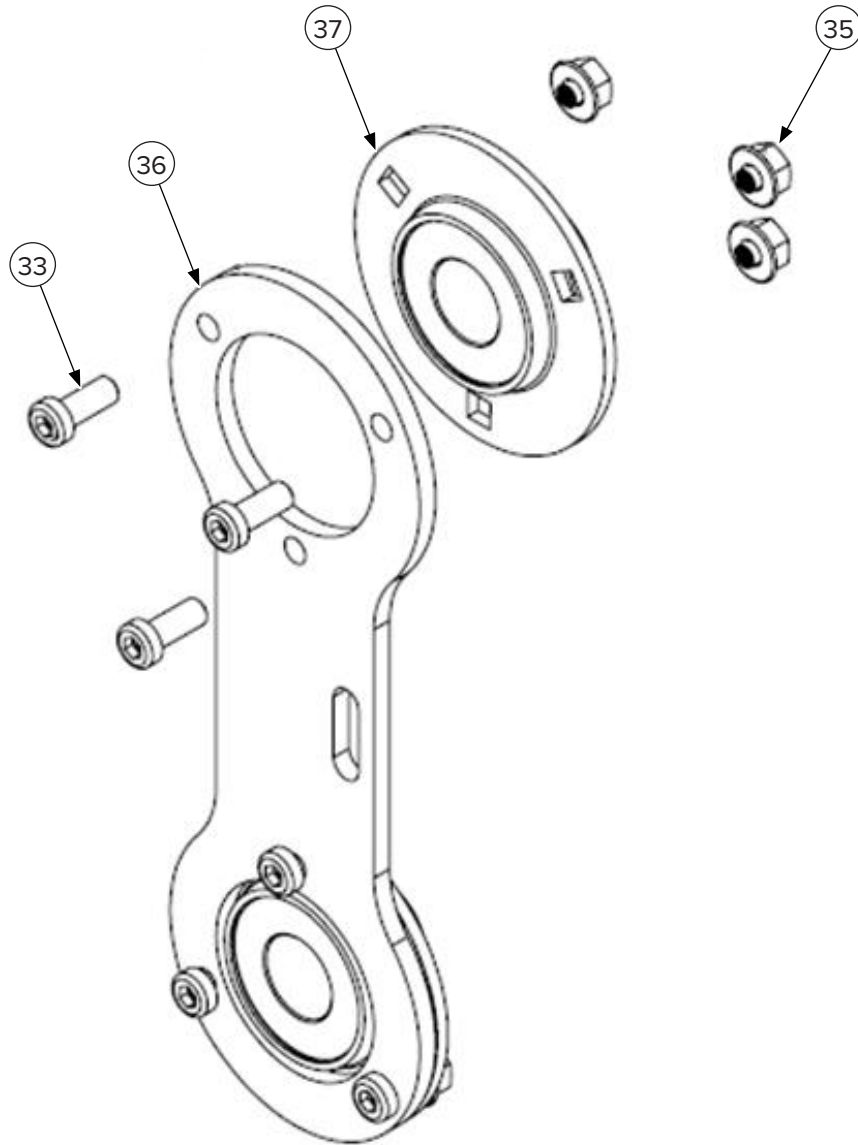

ITEM	PART NUMBER	DESCRIPTION	145135 QTY
33	—	M8 x 20 mm Socket Cap Screw	12
35	299343	M8 Flange Nut	12
36	—	Bearing Support Plate	2
37	245130	Bearing SLFE25C99	4

7. Parts

7.6 Motor Components

Motor Group Overview

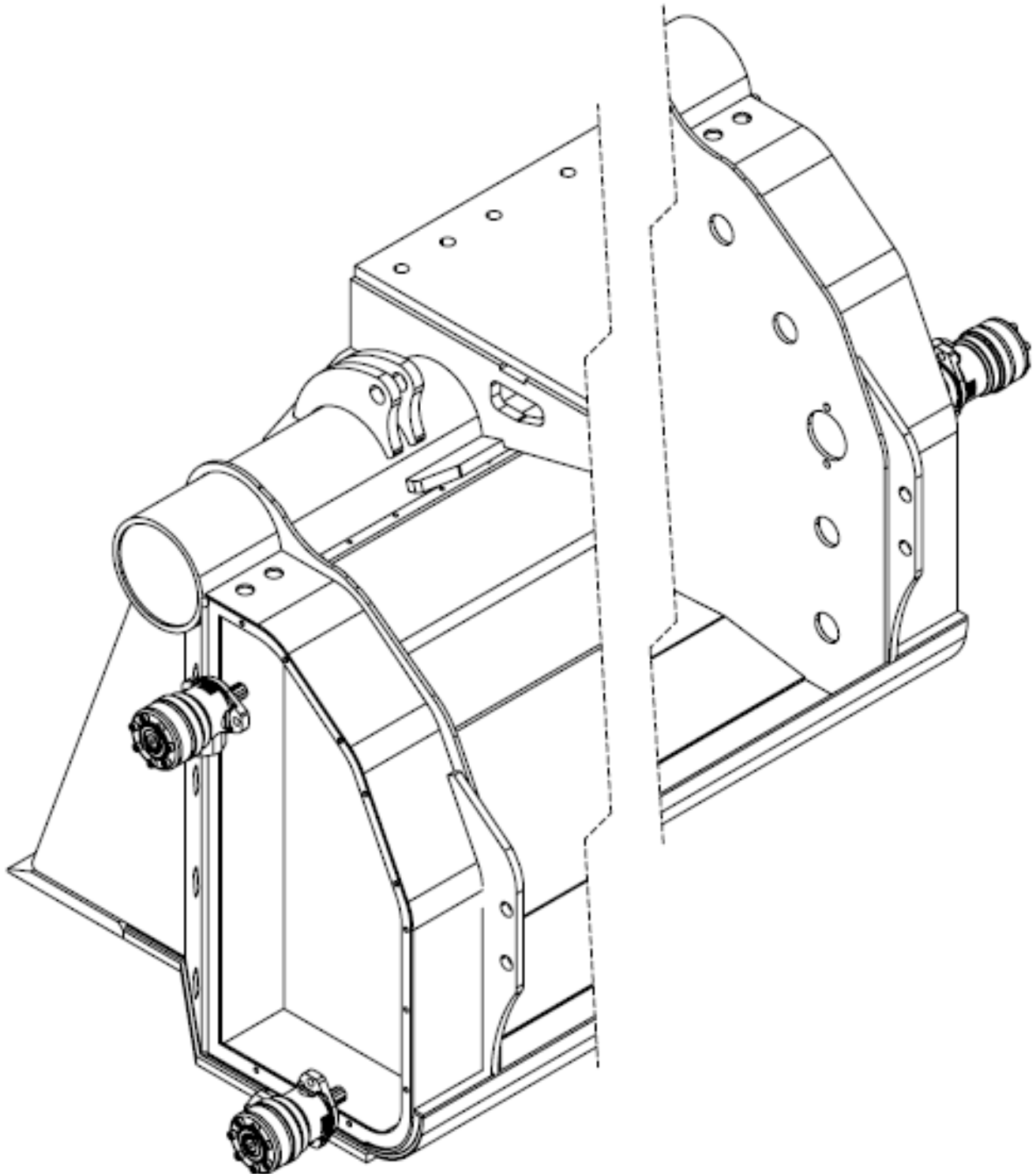

7. Parts

7.6 Motor Components Cont'd

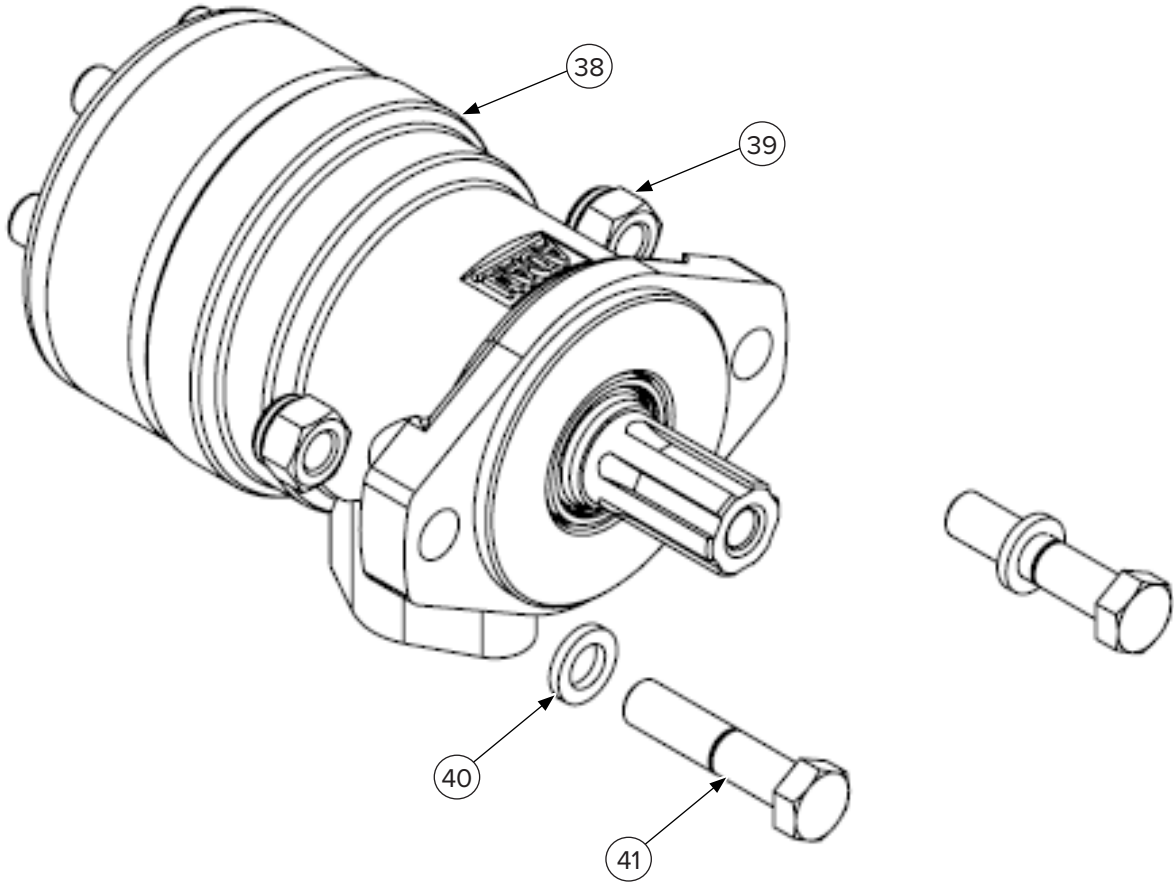

ITEM	PART NUMBER	DESCRIPTION	145135 QTY
38	—	MR Motor 160 cc 6B Shaft HP Shaft Seal	3
39	—	M12 Nylock Nut	6
40	—	M12 Form A Flat Washer	6
41	—	M12 x 50 mm Hexagon Bolt	6

7. Parts

7.6 Motor Components Cont'd

For All Models 2024 & Newer Only

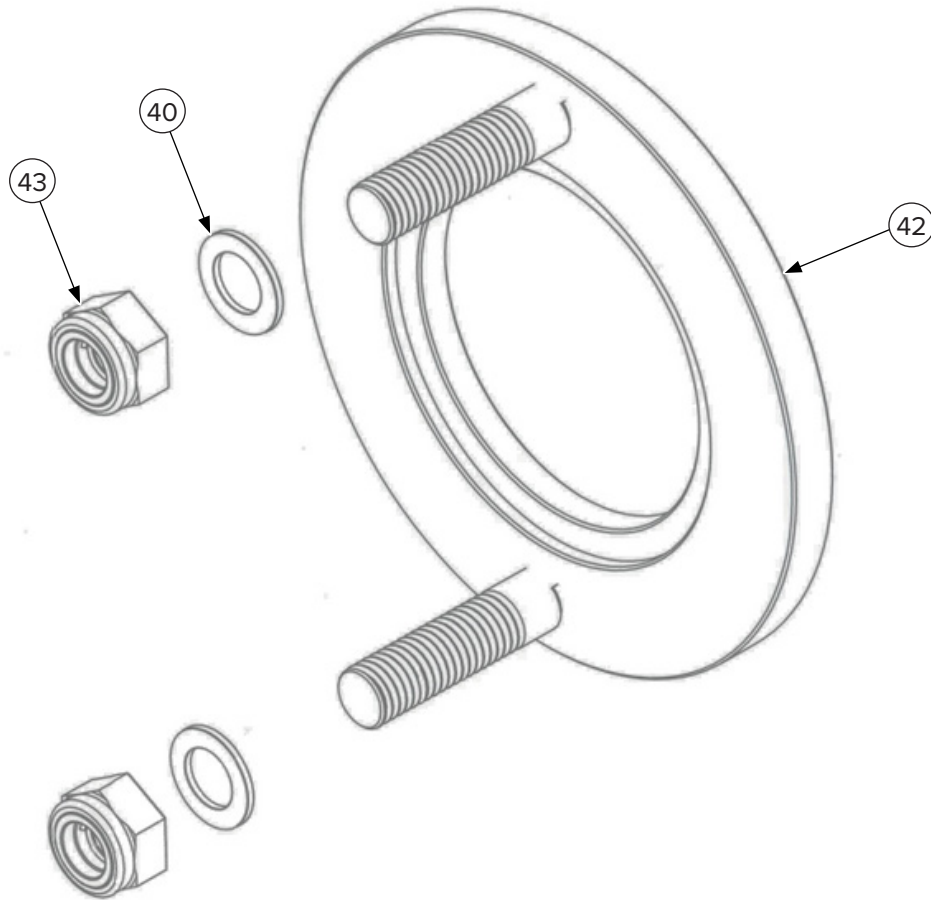

ITEM	PART NUMBER	DESCRIPTION	145135 QTY
40	—	M12 Form A Flat Washer	6
42	—	Sealing Ring	3
43	—	M12 Nylock Nut	6

NOTE: The sealing ring replaces M12 x 50 mm Hexagon Bolts in the motor assembly on page 34.

7. Parts

7.7 Hose Components

Group A

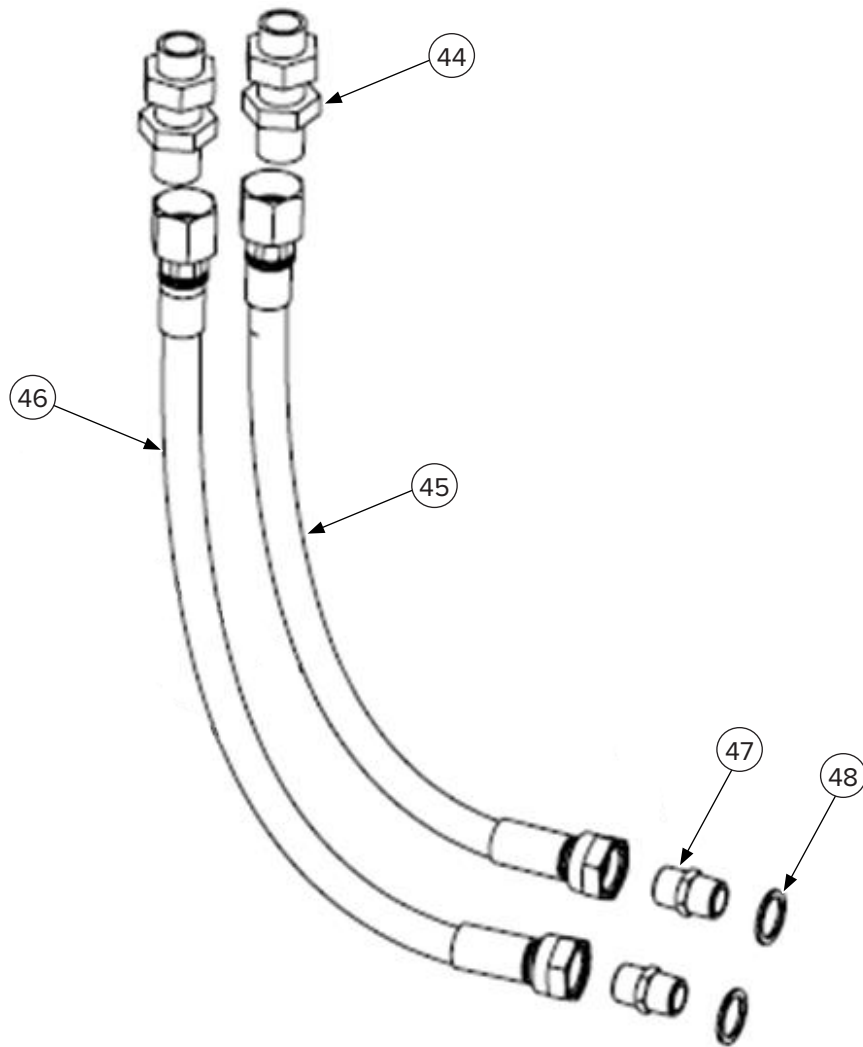

ITEM	PART NUMBER	DESCRIPTION	145135 QTY
44	—	Bulkhead Fitting 3/4" BSP	2
45	—	Hose	1
46	—	Hose	1
47	—	1/2" M – 1/2" M BSP Adapter	2
48	—	Bonded Seal 1/2"	2

7. Parts

7.7 Hose Components Cont'd Group B

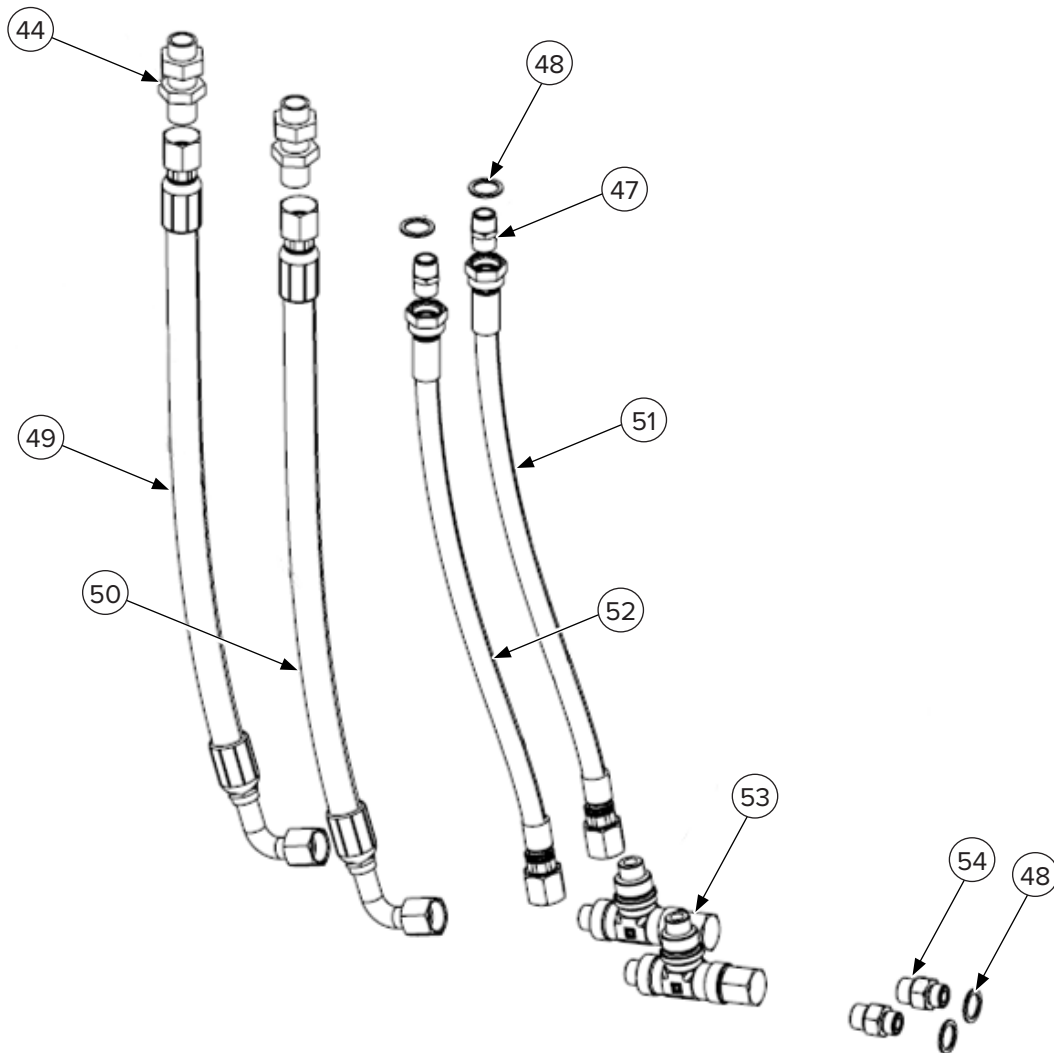

ITEM	PART NUMBER	DESCRIPTION	145135 QTY
44	—	Bulkhead Fitting 3/4" BSP	2
47	—	1/2" M – 1/2" M BSP Adapter	2
48	—	Bonded Seal 1/2"	4
49	—	Hose	1
50	—	Hose	1
51	—	Hose	1
52	—	Hose	1
53	—	Tee Fitting F–M–M 3/4" BSP	2
54	—	3/4" M BSP – 1/2" M BSP Adapter	2

7. Parts

7.8 Crossover Hose Components

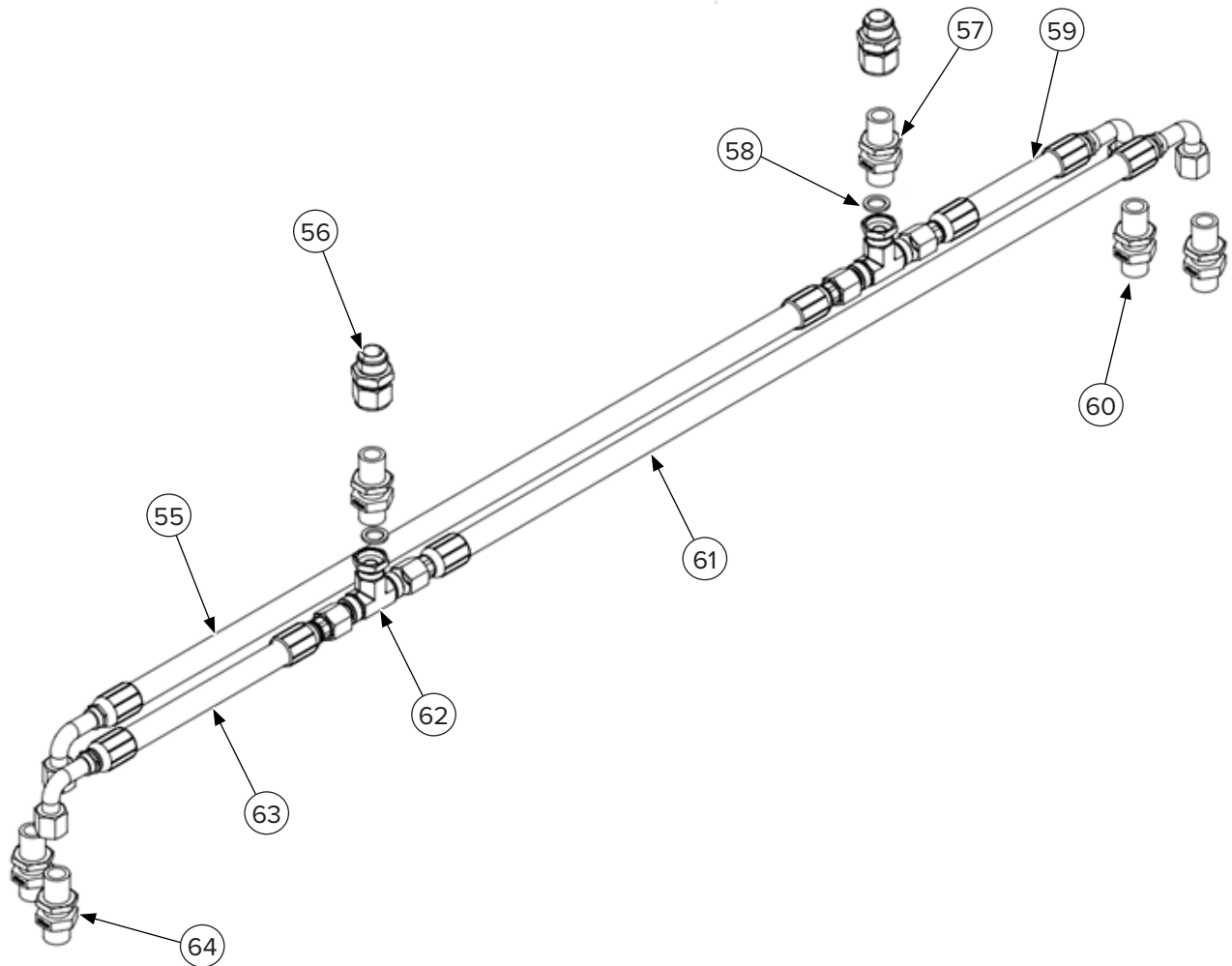

ITEM	PART NUMBER	DESCRIPTION	145135 QTY
55	—	Hose	1
56	—	1" BSP – 1 3/4" M JIC Adapter	2
57	—	Bulkhead Fitting 1" BSP	2
58	—	Bonded Seal 1"	2
59	—	Hose	1
60	See page 37	Hose, Group A	1
61	—	Hose	1
62	—	Tee Fitting F–F–F BSP 1"	2
63	—	Hose	1
64	See page 38	Hose, Group B	1

7. Parts

7.9 Door Components

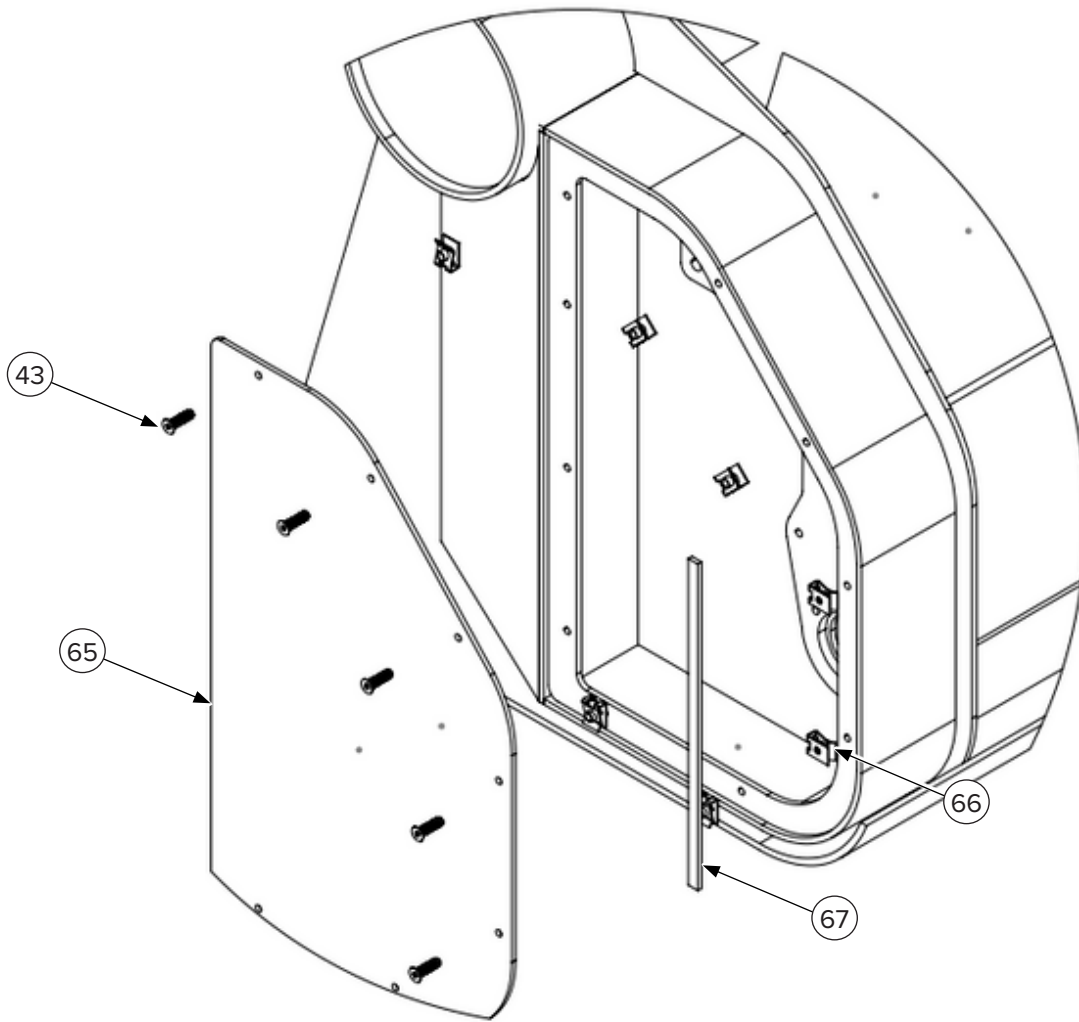

ITEM	PART NUMBER	DESCRIPTION	145135 QTY
43	—	M6 x 25 mm Socket Counter Screw	20
65	—	Left Door Cover	1
	—	Right Door Cover	1
66	—	M6 Speed Nut	20
67	—	Self Adhesive Seal 1 Meter Long	6

7. Parts

7.10 Stripper Plate Components

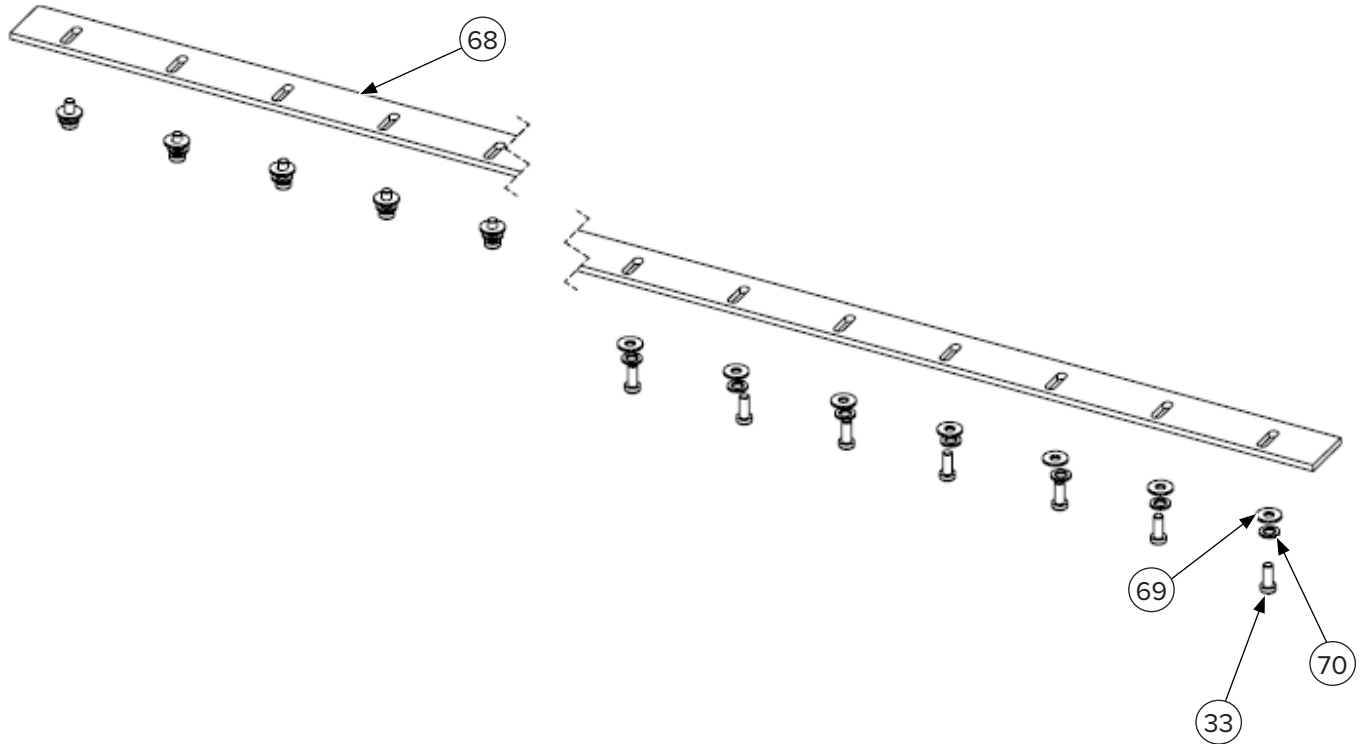

ITEM	PART NUMBER	DESCRIPTION	145135 QTY
33	—	M8 x 20 mm Socket Cap Screw	15
68	—	Stripper Plate	1
69	—	M8 Spring Washer	15
70	—	M8 Flat Washer	15

7. Parts

7.11 Comb Kit Components

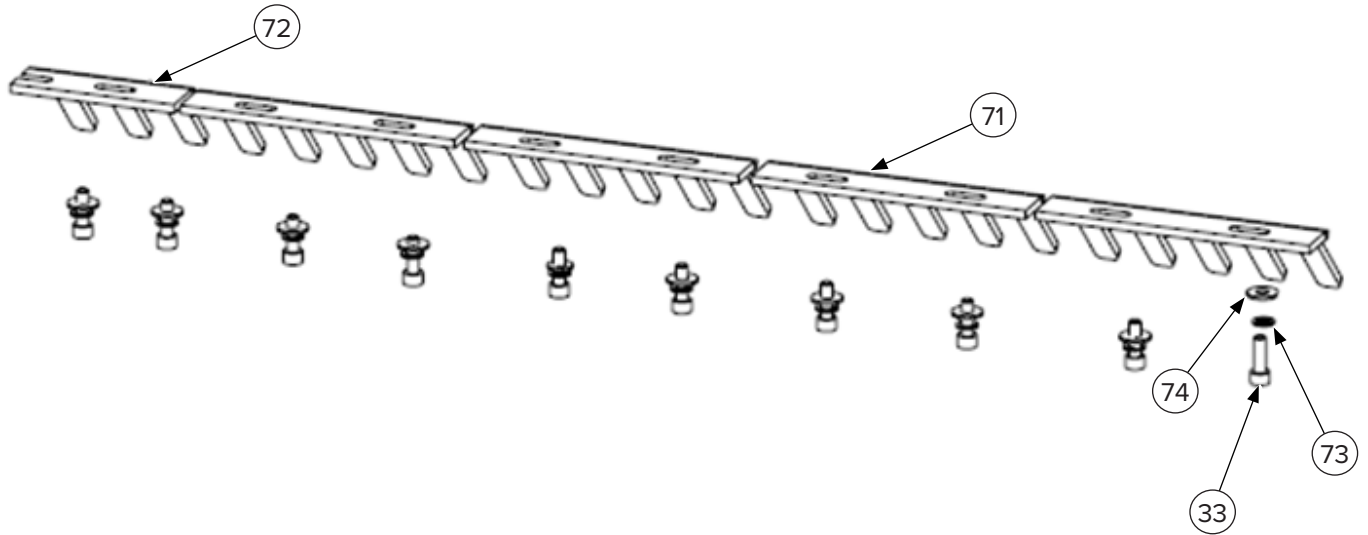

ITEM	PART NUMBER	DESCRIPTION	145135 QTY
NS	245006	Comb Kit (includes all item below)	1
33	—	M8 x 20 mm Socket Cap Screw	16
71	245012	Long Comb	7
72	245009	Short Comb (Right Hand Split)	1
73	—	M8 Spring Washer	16
74	—	M8 Flat Washer	16

7. Parts

7.12 Stone Guard Components

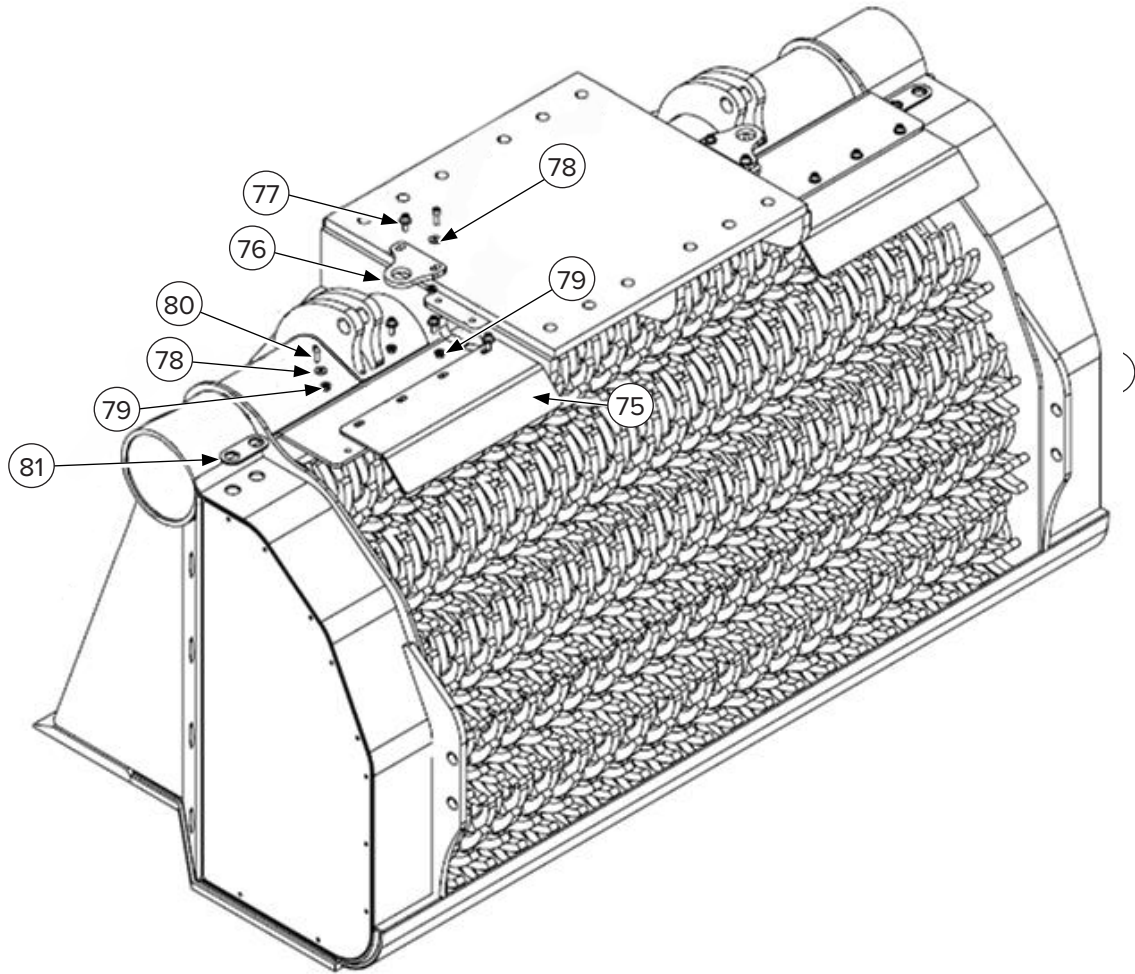

ITEM	PART NUMBER	DESCRIPTION	145135 QTY
75	—	Stone Guard	2
76	—	Hose Ear	2
77	—	M10 x 35 mm Socket Cap Screw	4
78	—	Flat Washer S10	20
79	—	M10 Nylock Nut	8
80	—	M10 x 30mm Socket Cap Screw	8
81	—	Hose Plate	2

7. Parts

7.13 Safety Decals

82 83



84



85



86



87



88

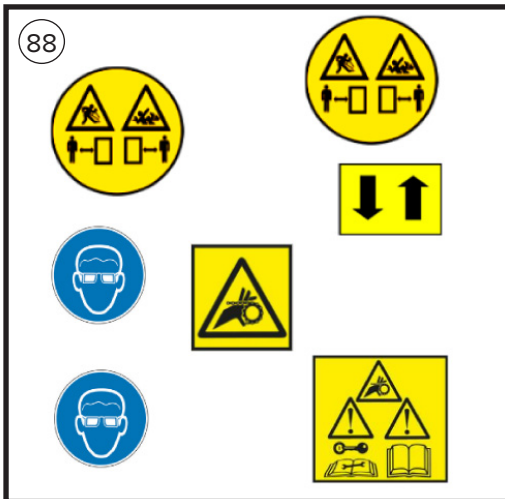

89

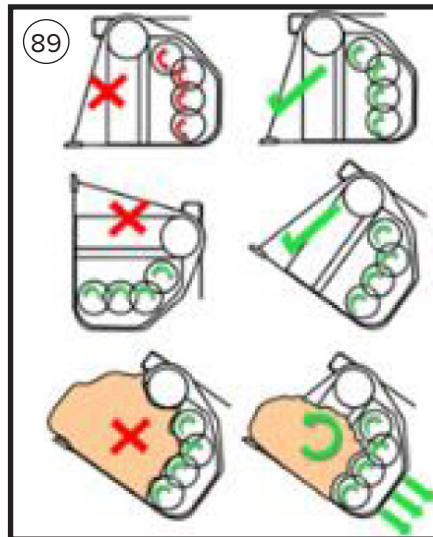

ITEM	PART NUMBER	DESCRIPTION	QTY
82	BD-060	2.4375" x 3.375" Decal, Blue Diamond Attachments Diamond Shape	2
83	BD-112	12.18" x 9.47" Decal, Blue Diamond Attachments Diamond Shape	2
84	BD-092	1.5" x 2.0" Decal, Warranty Registration QR	1
85	BD-123	3.0" x 3.0" Decal, High Pressure Fluid Hazard	1
86	BD-001	3.0" x 3.0" Decal, Read Owner's Manual	1
87	BD-131	Decal, Tagline Double Line 2" Tall	2
88	—	Safety Decal Kit (not sold separately)	1
89	—	Advisory Decal	1

8. Specifications

8.1 Attachment Specifications

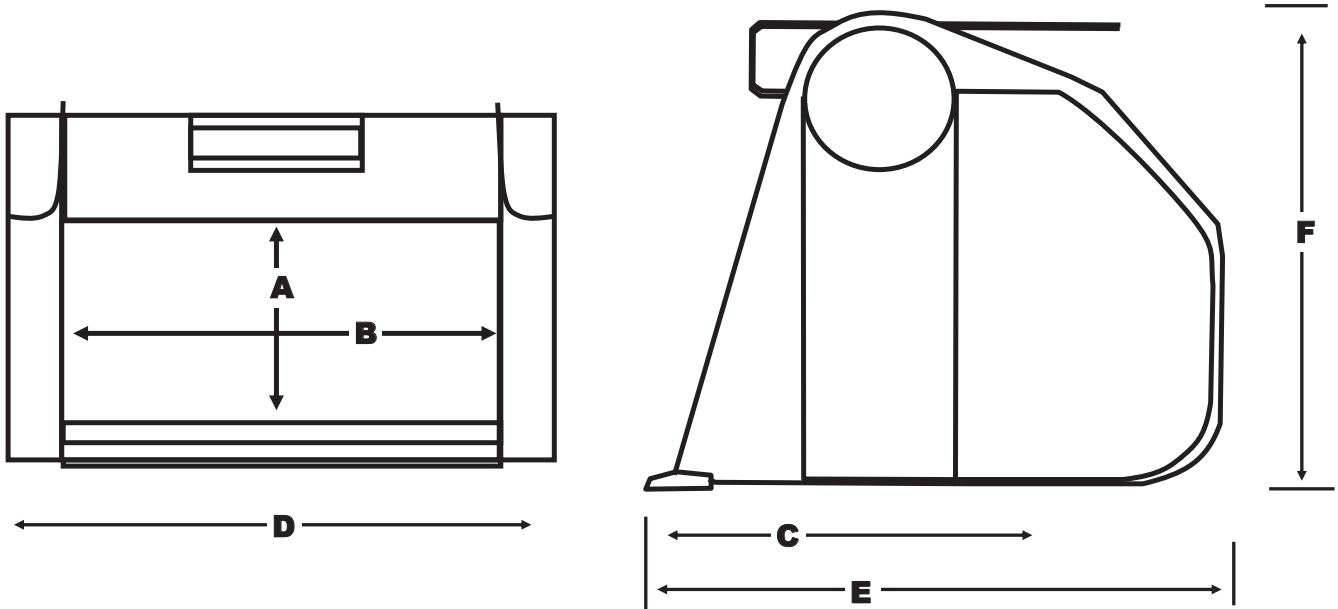

DESCRIPTION	145135
Screening Height (A)	41 in. (1030 mm)
Screening Width (B)	59 in. (1500 mm)
Scooping Depth (C)	35 in. (900 mm)
Overall Width (D)	74 in. (1870 mm)
Overall Depth (E)	53 in. (1340 mm)
Overall Height (F)	51 in. (1300 mm)
Capacity	1.57 yd. ³ (1.2 m ³)
Hydraulic Flow	42 GPM (150 L/m)
Hydraulic Pressure	2900 PSI (200 bar)
Weight	1635 lbs (742 kg)

8. Specifications

8.2 Torque Specifications – Metric

Standard Hardware and Lock Nuts

BOLT TYPE	CLASS 4.8		CLASS 8.8 OR 9.8		CLASS 10.9		CLASS 12.9	
	Lubricated	Dry	Lubricated	Dry	Lubricated	Dry	Lubricated	Dry
M6	4.8 N•m	6 N•m	9 N•m	11 N•m	13 N•m	17 N•m	15 N•m	19 N•m
	3.5 lbf•ft	4.5 lbf•ft	6.5 lbf•ft	8.5 lbf•ft	9.5 lbf•ft	12 lbf•ft	11.5 lbf•ft	14.5 lbf•ft
M8	12 N•m	15 N•m	22 N•m	28 N•m	32 N•m	40 N•m	37 N•m	47 N•m
	8.5 lbf•ft	11 lbf•ft	16 lbf•ft	20 lbf•ft	24 lbf•ft	30 lbf•ft	28 lbf•ft	35 lbf•ft
M10	23 N•m	29 N•m	43 N•m	55 N•m	63 N•m	80 N•m	75 N•m	95 N•m
	17 lbf•ft	21 lbf•ft	32 lbf•ft	40 lbf•ft	47 lbf•ft	60 lbf•ft	55 lbf•ft	70 lbf•ft
M12	40 N•m	50 N•m	75 N•m	95 N•m	110 N•m	140 N•m	130 N•m	165 N•m
	29 lbf•ft	37 lbf•ft	55 lbf•ft	70 lbf•ft	80 lbf•ft	105 lbf•ft	95 lbf•ft	120 lbf•ft
M14	63 N•m	80 N•m	120 N•m	150 N•m	175 N•m	225 N•m	205 N•m	260 N•m
	47 lbf•ft	60 lbf•ft	88 lbf•ft	110 lbf•ft	130 lbf•ft	165 lbf•ft	150 lbf•ft	190 lbf•ft
M16	135 N•m	175 N•m	260 N•m	330 N•m	375 N•m	475 N•m	440 N•m	560 N•m
	100 lbf•ft	125 lbf•ft	195 lbf•ft	250 lbf•ft	275 lbf•ft	350 lbf•ft	325 lbf•ft	410 lbf•ft
M18	135 N•m	175 N•m	260 N•m	330 N•m	375 N•m	475 N•m	440 N•m	560 N•m
	100 lbf•ft	125 lbf•ft	195 lbf•ft	250 lbf•ft	275 lbf•ft	350 lbf•ft	325 lbf•ft	410 lbf•ft
M20	190 N•m	240 N•m	375 N•m	475 N•m	530 N•m	675 N•m	625 N•m	800 N•m
	140 lbf•ft	180 lbf•ft	275 lbf•ft	350 lbf•ft	400 lbf•ft	500 lbf•ft	460 lbf•ft	580 lbf•ft
M22	260 N•m	330 N•m	510 N•m	650 N•m	725 N•m	925 N•m	850 N•m	1075 N•m
	190 lbf•ft	250 lbf•ft	375 lbf•ft	475 lbf•ft	540 lbf•ft	675 lbf•ft	625 lbf•ft	800 lbf•ft
M24	330 N•m	425 N•m	650 N•m	825 N•m	925 N•m	1150 N•m	1075 N•m	1350 N•m
	250 lbf•ft	310 lbf•ft	475 lbf•ft	600 lbf•ft	675 lbf•ft	850 lbf•ft	800 lbf•ft	1000 lbf•ft
M27	490 N•m	625 N•m	950 N•m	1200 N•m	1350 N•m	1700 N•m	1600 N•m	2000 N•m
	360 lbf•ft	450 lbf•ft	700 lbf•ft	875 lbf•ft	1000 lbf•ft	1250 lbf•ft	1150 lbf•ft	1500 lbf•ft
M30	675 N•m	850 N•m	1300 N•m	1650 N•m	1850 N•m	2300 N•m	2150 N•m	2700 N•m
	490 lbf•ft	625 lbf•ft	950 lbf•ft	1200 lbf•ft	1350 lbf•ft	1700 lbf•ft	1600 lbf•ft	2000 lbf•ft
M33	900 N•m	1150 N•m	1750 N•m	2200 N•m	2500 N•m	3150 N•m	2900 N•m	3700 N•m
	675 lbf•ft	850 lbf•ft	1300 lbf•ft	1650 lbf•ft	1850 lbf•ft	2350 lbf•ft	2150 lbf•ft	2750 lbf•ft
M36	1150 N•m	1450 N•m	2250 N•m	2850 N•m	3200 N•m	4050 N•m	3750 N•m	4750 N•m
	850 lbf•ft	1075 lbf•ft	1650 lbf•ft	2100 lbf•ft	2350 lbf•ft	3000 lbf•ft	2750 lbf•ft	3500 lbf•ft



Warranty

MANUFACTURER'S LIMITED WARRANTY

BLUE DIAMOND® ATTACHMENTS, a manufacturer of quality attachments, warrants new BLUE DIAMOND® ATTACHMENTS products and/or attachments at the time of delivery to the original purchaser, to be free from defects in material and workmanship when properly set up and operated in accordance with the recommendations set forth by BLUE DIAMOND® ATTACHMENTS, LLC.

BLUE DIAMOND® ATTACHMENTS liability for any defect with respect to accepted goods shall be limited to repairing the goods at a BLUE DIAMOND® ATTACHMENTS designated location or at an authorized dealer location, or replacing them, as BLUE DIAMOND® ATTACHMENTS shall elect. The above shall be in accordance with BLUE DIAMOND® ATTACHMENTS warranty adjustment policies. BLUE DIAMOND® ATTACHMENTS obligation shall terminate twelve (12) months for the Screening Bucket after the delivery of the goods to original purchaser.

This warranty shall not apply to any machine or attachment which shall have been repaired or altered outside the BLUE DIAMOND® ATTACHMENTS factory or authorized BLUE DIAMOND® ATTACHMENTS dealership or in any way so as in BLUE DIAMOND® ATTACHMENTS judgment, to affect its stability or reliability, nor which has been subject to misuse, negligence or accident beyond the company recommended machine rated capacity.

WARRANTY CLAIM

To submit a warranty claim, a claim must be filed with BLUE DIAMOND® ATTACHMENTS before work is performed. The BLUE DIAMOND® PRODUCT SUPPORT TEAM will advise repairs and applicable parts exchanges. Tampering with the failed part may void the warranty. This warranty does not include freight or delivery charges incurred when returning machinery for servicing. Dealer mileage, service calls, and pickup/delivery charges are the customers' responsibility.

EXCLUSIONS OF WARRANTY

Except as otherwise expressly stated herein, BLUE DIAMOND® ATTACHMENTS makes no representation or warranty of any kind, expressed or implied, AND MAKES NO WARRANTY OF MERCHANTABILITY IN RESPECT TO ITS MACHINERY AND/OR ATTACHMENTS ARE FIT FOR ANY PARTICULAR PURPOSE. BLUE DIAMOND® ATTACHMENTS shall not be liable for incidental or consequential damages for any breach or warranty, including but not limited to inconvenience, rental of replacement equipment, loss of profits or other commercial loss. Upon purchase, the buyer assumes all liability for all personal injury and property resulting from the handling, possession, or use of the goods by the buyer.

No agent, employee, or representative of BLUE DIAMOND® ATTACHMENTS has any authority to bind BLUE DIAMOND® ATTACHMENTS to any affirmation, representation, or warranty concerning its machinery and/or attachments except as specifically set forth herein.

This warranty policy supersedes any previous documents. Please see bluediamondattachments.com/warranty-policies for the most up to date warranty information.

NOTE: Blue Diamond® Attachments is a trademark of BLUE DIAMOND® ATTACHMENTS



QUALITY | DEPENDABILITY | INTEGRITY

Blue Diamond® Attachments
4512 Anderson Road, Knoxville, TN 37918
888-376-7027