

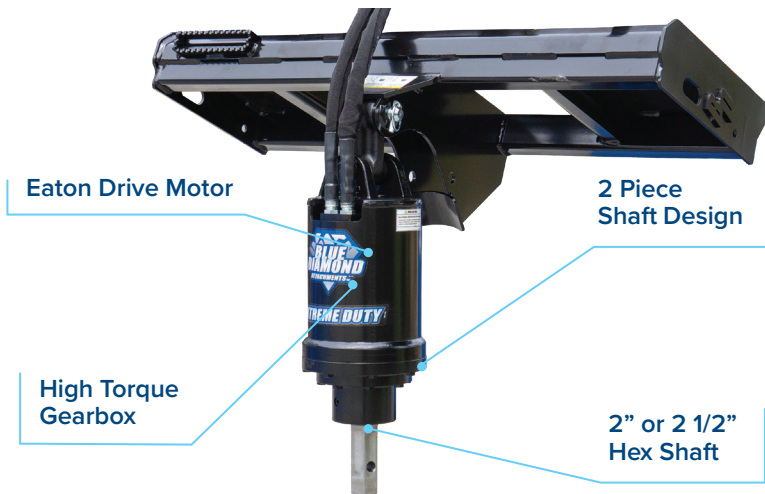

# AUGER DRIVE EXTREME DUTY SERIES 2



The **Blue Diamond® Extreme Duty Augers** deliver maximum torque, durability, and efficiency for tough drilling applications. Engineered for precision and built to handle rocky or heavy soils. Designed with high-grade materials and innovation, this attachment allows the gearbox to go down the hole, maximizing drilling depth while eliminating downtime.



Eaton Drive Motor

2 Piece Shaft Design

High Torque Gearbox

2" or 2 1/2" Hex Shaft

## KEY FEATURES

- ◆ Compact high torque manufactured gearbox
- ◆ 2 piece shaft design ensuring maximum side load ratings
- ◆ 5-year gearbox warranty, 3-year motor warranty, and lifetime shaft pull-out warranty
- ◆ Universal skid steer mount with welded cradle and dual-pin design for natural hanging and stable drilling
- ◆ Telescopic skid steer mount available for extended reach and drilling depth

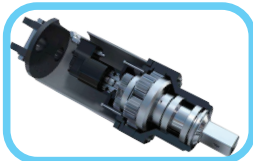

2-piece shaft design and high torque gearbox



Mini excavator mounts available



Full-sized excavator mounts available



Heavy Duty Bits    Heavy Duty Bits w/ Cast Heads    Rock Bits    Tree Bits

Auger bits, auger extensions, and adapters are available to suit different ground conditions and drilling applications

MODEL	EX1	EX2	EX3	EX4	EX4HF	EX5HF	EX6HF	EX7HF
PART NUMBER	305705	305708	305712	305715	305720	305725	305728	305730
TORQUE FT-LBS @ 3000 PSI	1,467	2,254	2,829	3,275	3,583	3,903	4,909	6,162
MAX TORQUE FT-LBS 3500 PSI	1,712	2,630	3,300	3,821	4,180	4,553	5,728	7,189
RECOMMENDED FLOW (GPM)	8-11	12-16	17-20	19-23	21-26	24-29	29-32	33-36
MAX PRESSURE – DO NOT EXCEED	3500 psi @ 16 gpm				3500 psi @ 27 gpm			
MAX FLOW – DO NOT EXCEED	30 GPM @ 1800 PSI	30 GPM @ 1800 PSI	30 GPM @ 1800 PSI	30 GPM @ 1800 PSI	42 GPM @ 3100 PSI	55 GPM @ 1700 PSI	55 GPM @ 1700 PSI	55 GPM @ 1700 PSI
MAX HP	33				55			
PRESSURE RELIEF VALVE	N/A				Included			
STANDARD OUTPUT SHAFT	2" Hex					2 1/2" Hex		
MAX DRILLING DIA. (CLAY/SHALE)	12"	24"			30"			
MAX DRILLING DIAMETER (DIRT)	24"	30"			40"		48"	
WEIGHT (LBS)	260	277	367	280	337	462	477	488
OVERALL LENGTH (IN)	24.5"	25.9"			29"	33.7"		
DIAMETER (IN)	7.4"	9.4"				11.4"		
OUTPUT SPEED - MIN *	38 RPM @ 6 GPM	41 RPM @ 10 GPM	33 RPM @ 10 GPM	28 RPM @ 10 GPM	22 RPM @ 8 GPM	24 RPM @ 10 GPM	22 RPM @ 12 GPM	21 RPM @ 14 GPM
OUTPUT SPEED - MAX *	100 RPM @ 16 GPM	73 RPM @ 18 GPM	98 RPM @ 30 GPM	84 RPM @ 30 GPM	108 RPM @ 42 GPM	85 RPM @ 36 GPM	67 RPM @ 36 GPM	54 RPM @ 36 GPM

\*Output speed and torque are theoretical and depend on the prime mover's hydraulic efficiency. Use for reference only; contact Blue Diamond for application-specific data.

